

FINISH SCHEDULE	
WD-4	PLYBOO VENEER - CARMELIZED FLAT CUT - 20% SHEEN CLEAR
WD-5	PLYBOO - CARMELIZED FLAT CUT - 20% SHEEN CLEAR
WC-2	PHILLIP JEFFRIES ISLAND - 7867 CAPRI NATURAL
LAM-1	HARD ROCK MAPLE
LT-1	STRIP LIGHTS 3000K

PARTS LIST										
ITEM	QTY	PART NUMBER	C.C.	DESCRIPTION	Length	Width	Thk.	Material	Finish	EB
1	4	3083-003-BB		CENTER PILASTER TOP					SEE PG. 6	
2	1	3083-003-CA		RIGHT PILASTER LOWER					SEE PG. 7	
3	1	3083-003-CB		RIGHT PILASTER TOP					SEE PG. 8	
4	9	3083-003-D		WALL CLEAT					SEE PG. 9	
5	1	3083-003-AA		PILASTER - LEFT WING - W/O CAB					SEE PG. 3	
6	1	3083-003-AB		PILASTER - LEFT WING - TOP					SEE PG. 4	
7	2	3083-003-BA		PILASTER - CAB RIGHT - OPEN LEFT					SEE PG. 5	
8	2	3083-003-CA		PILASTER - RIGHT OPEN - LEFT CAB					SEE PG. 10	
9	4	3083-003-E		TOE KICK - 48 INCH					SEE PG. 11	
10	1	3083-003-F		TOE KICK - 60 INCH					SEE PG. 12	
11	4	3083-003-G		MID SHELF - 48 INCH					SEE PG. 13	
12	1	3083-003-H		MID SHELF - 60 INCH					SEE PG. 15	
13	4	3083-003-J		TOP SHELF - 48 INCH					SEE PG. 17	
14	1	3083-003-K		TOP SHELF - 60 INCH					SEE PG. 18	
15	4	3083-003-L		LOUVER ASSEMBLY - 48 INCH					SEE PG. 19	
16	1	3083-003-M		LOUVER ASSEMBLY - 60 INCH					SEE PG. 21	
17	1	3083-003-N		CABINET - 48 INCH					SEE PG. 23	
18	1	3083-003-P		CABINET - 60 INCH					SEE PG. 25	
19	3	3083-003-R		STANDARDS PANEL ASSEMBLY - 48 IN W/O CAB					SEE PG. 27	
20	1	3083-003-T		STANDARDS PANEL ASSEMBLY - 48 IN W/ CAB					SEE PG. 287	
21	1	3083-003-U		STANDARDS PANEL ASSEMBLY - 60 IN W/ CAB					SEE PG. 29	
22	6	3083-003-VA		FINISH PANEL ASSEMBLY - 48 IN W/O CAB					SEE PG. 30	
23	2	3083-003-VB		FINISH PANEL ASSEMBLY - 48 IN W/ CAB - OUTSIDE					SEE PG. 31	
24	2	3083-003-VC		FINISH PANEL ASSEMBLY - 60 IN - OUTSIDE					SEE PG. 32	
25	3	3083-003-WA		FINISH PANEL ASSEMBLY - 48 IN W/O CAB - CENTER					SEE PG. 33	
26	1	3083-003-WB		FINISH PANEL ASSEMBLY - 48 IN W/ CAB - CENTER					SEE PG. 34	
27	1	3083-003-WC		FINISH PANEL ASSEMBLY - 60 IN - CENTER					SEE PG. 35	
28	2	3083-003-YA_		ADJUSTABLE SHELF - 48 INCH					SEE PG. 36	
29	2	3083-003-YB_		ADJUSTABLE SHELF - 60 INCH					SEE PG. 38	

DATE: 3/9/2026

DRAWN BY: BH

FIGURE NAME: BB-01

PART #: VARIES

JOB#: 3083

SHEET#: 003.1

NAPLES BEACH BOUTIQUE
NAPLES, FL

NORTH WALL

Description:



VIEW3
SCALE 1/36

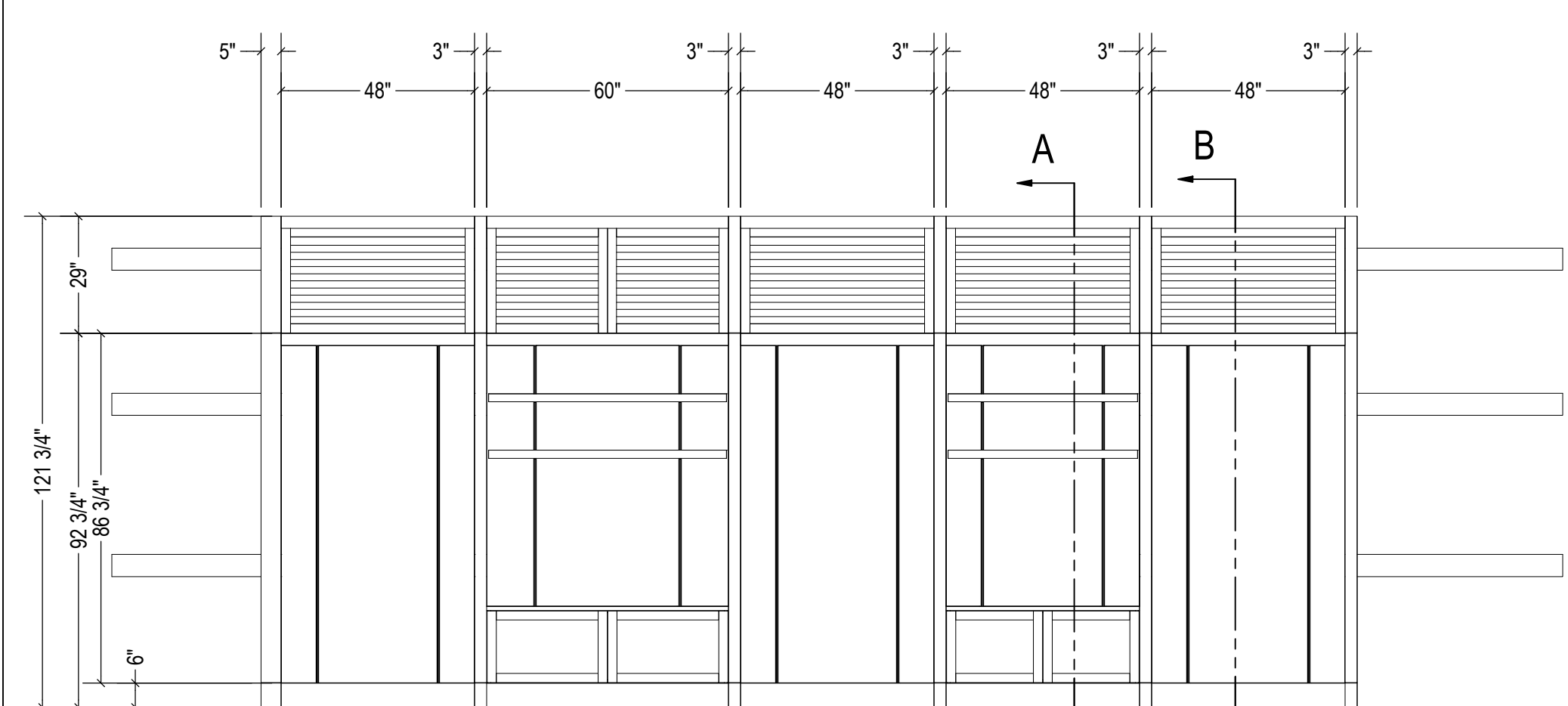

FRONT
SCALE 1/36

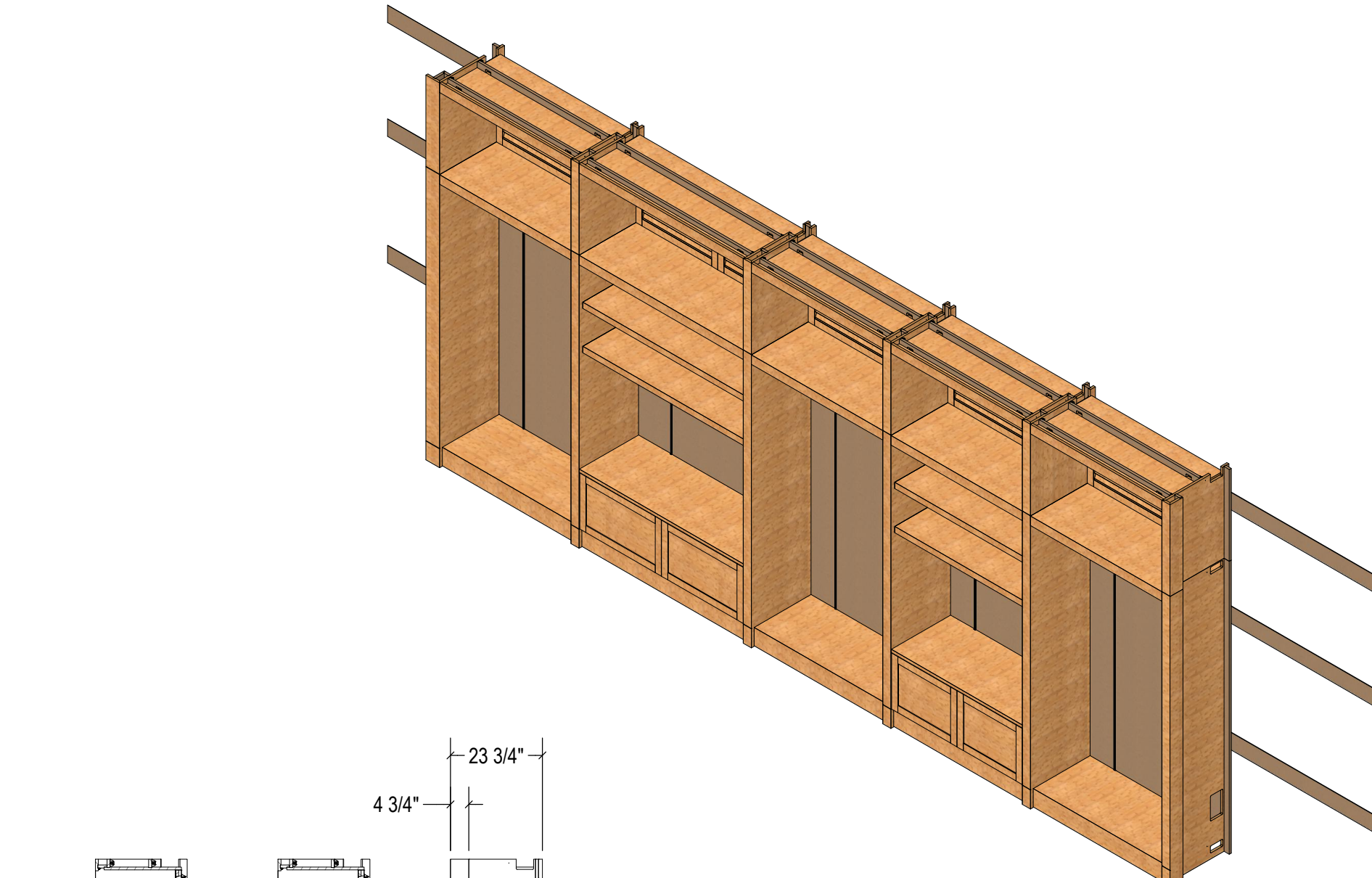

ISO
SCALE 1/36

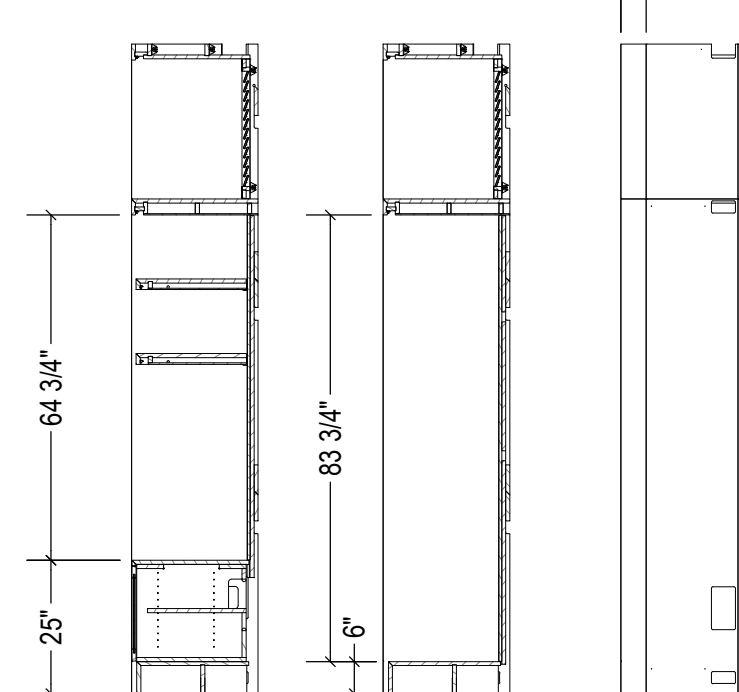

SECTION A
SCALE 1/36

SECTION B
SCALE 1/36

VIEW2
SCALE 1/36

Display Craft
MANUFACTURING CO.

3939 WASHINGTON BOULEVARD BALTIMORE, MARYLAND 21227-4165
PH: (410) 242-0400 FX: (410) 242-0475
A DIVISION OF WEITZMAN INDUSTRIES, INC.

- REVISIONS -

BY	DATE	REMARKS

THIS DRAWING REMAINS THE PROPERTY OF DISPLAY CRAFT MFG CO. THE INFORMATION CONTAINED HEREON IS FOR THE SPECIFIC USE OF THE INDIVIDUAL PROJECT, AND MAY NOT BE USED FOR ANY OTHER PURPOSE WITHOUT THE WRITTEN CONSENT OF DISPLAY CRAFT MFG. CO.

FINISH SCHEDULE	
WD-4	PLYBOO VENEER - CARMELIZED FLAT CUT - 20% SHEEN CLEAR
WD-5	PLYBOO - CARMELIZED FLAT CUT - 20% SHEEN CLEAR
WC-2	PHILLIP JEFFRIES ISLAND - 7867 CAPRI NATURAL
LAM-1	HARD ROCK MAPLE
LT-1	STRIP LIGHTS 3000K

PARTS LIST										
ITEM	QTY	PART NUMBER	C.C.	DESCRIPTION	Length	Width	Thk.	Material	Finish	EB
1	1	3083-003A-AA-002	FC	DEPTH	92.75	4.122	0.76	Medium Density Fiberboard		N/A
2	1	3083-003A-AA-01	FC	RIGHT - W/O CAB	92.75	23.75	0.765	PLYBOO G2S	20% SHEEN CLEAR	N/A
3	1	3083-003A-AA-02	FC	FRONT	92.75	5	0.765	PLYBOO G2S	20% SHEEN CLEAR	N/A
4	2	3083-003A-AA-001	FS	SPACER	92.75	2	0.76	Medium Density Fiberboard		N/A
5	4	BUTTON_FIX-BUTTON-01	P	BUTTON FIX - BUTTON						N/A

DATE:	3/9/2026
DRAWN BY:	BH
FIXTURE NAME:	BB-01
PART #:	3083-003A-AA
JOB #:	3083
SHEET #:	003.3

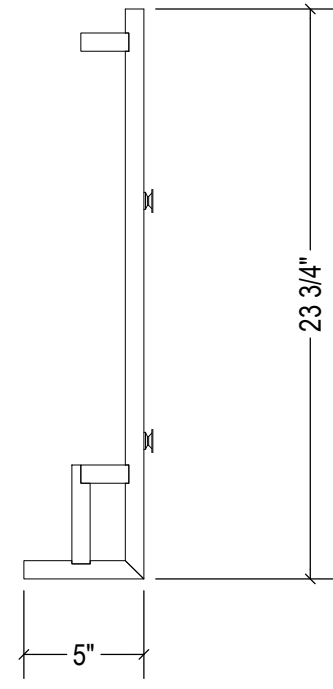

TOP
SCALE 1/8

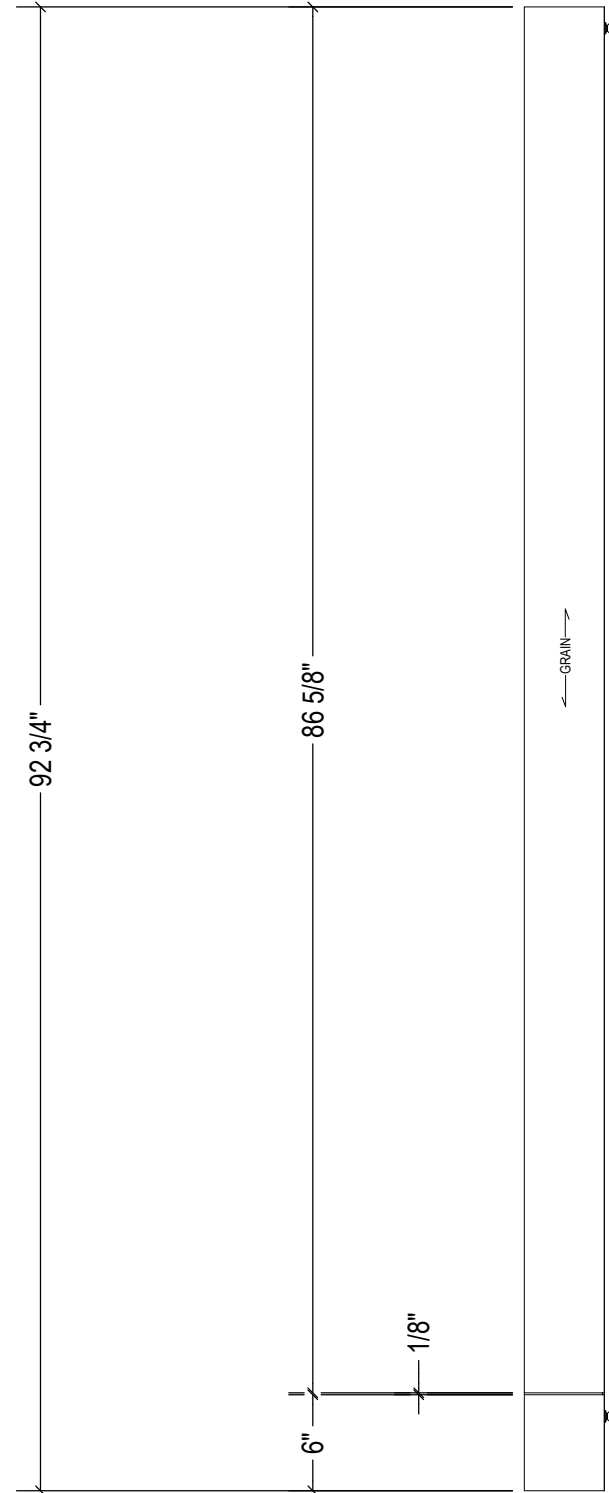

FRONT
SCALE 1/12

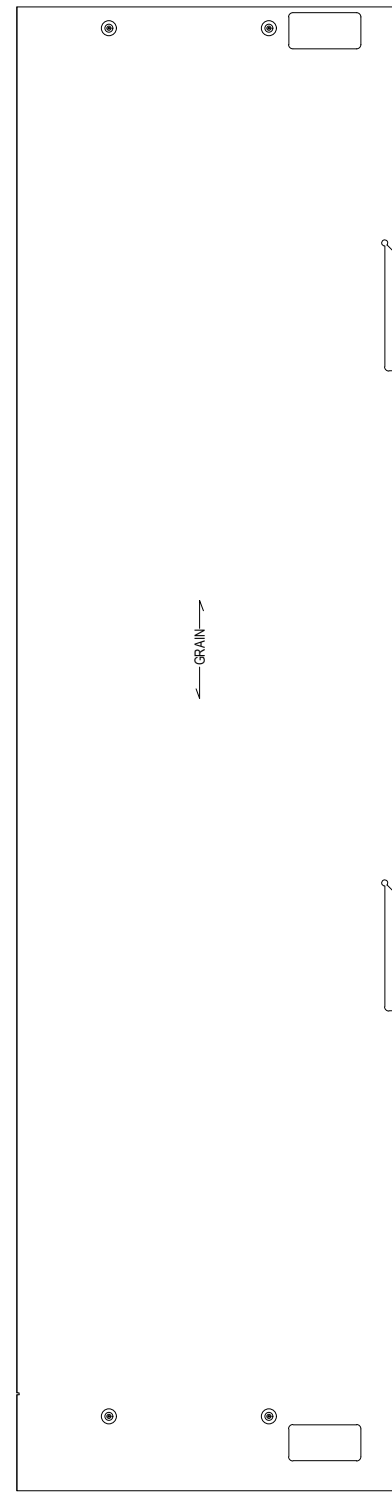

RIGHT
SCALE 1/12

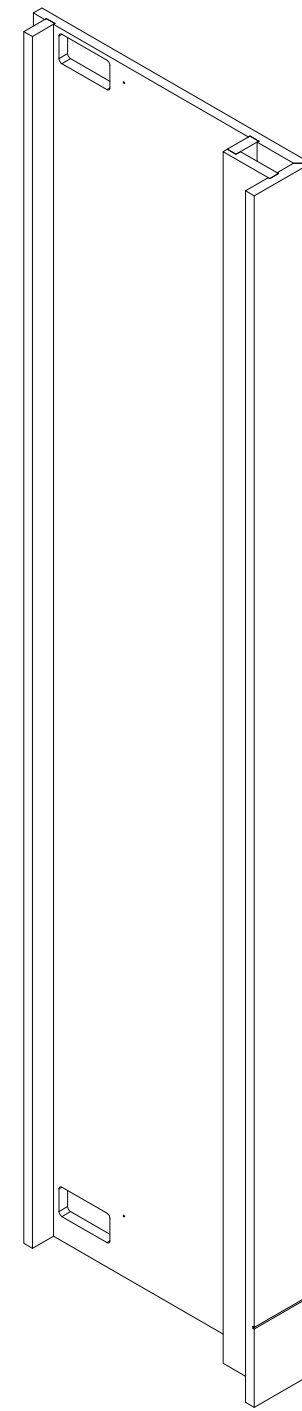

LEFT ISO
SCALE 1/12

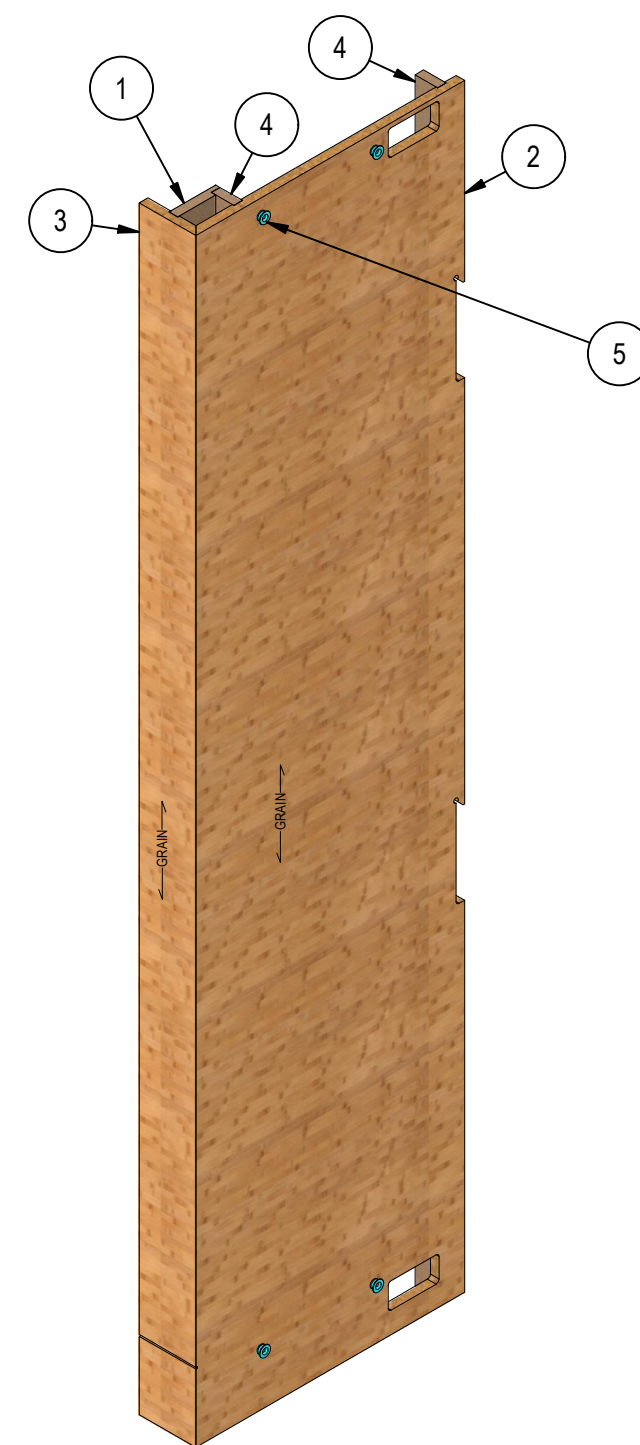

RIGHT ISO
SCALE 1/12

NAPLES BEACH BOUTIQUE
NAPLES, FL

PILASTER - LEFT WING - W/O CAB



3939 WASHINGTON BOULEVARD BALTIMORE, MARYLAND 21227-4165
PH: (410) 242-0400 FX: (410) 242-0475
A DIVISION OF WEITZMAN INDUSTRIES, INC.

- REVISIONS -

BY	DATE	REMARKS

THIS DRAWING REMAINS THE PROPERTY OF DISPLAY CRAFT MFG. CO. THE INFORMATION CONTAINED HEREON IS FOR THE SPECIFIC USE OF THE INDIVIDUAL PROJECT, AND MAY NOT BE USED FOR ANY OTHER PURPOSE WITHOUT THE WRITTEN CONSENT OF DISPLAY CRAFT MFG. CO.

FINISH SCHEDULE	
WD-4	PLYBOO VENEER - CARMELIZED FLAT CUT - 20% SHEEN CLEAR
WD-5	PLYBOO - CARMELIZED FLAT CUT - 20% SHEEN CLEAR
WC-2	PHILLIP JEFFRIES ISLAND - 7867 CAPRI NATURAL
LAM-1	HARD ROCK MAPLE
LT-1	STRIP LIGHTS 3000K

PARTS LIST										
ITEM	QTY	PART NUMBER	C.C.	DESCRIPTION	Length	Width	Thk.	Material	Finish	EB
1	2	90295A150								
2	1	3083-003A-AB-102	FC	DEPTH	29	4.122	0.76	Medium Density Fiberboard		N/A
3	1	3083-003A-AB-11	FC	RIGHT	29	23.75	0.765	PLYBOO G2S	20% SHEEN CLEAR	N/A
4	1	3083-003A-AB-12	FC	FRONT	29	5	0.765	PLYBOO G2S	20% SHEEN CLEAR	N/A
5	2	3083-003-AB-005	FM	SPLICE	5.5	1.47	0.76	Medium Density Fiberboard		N/A
6	2	3083-003A-AB-101	FS	SPACER	29	2	0.76	Medium Density Fiberboard		N/A
7	4	BUTTON_FIX-BUTTON-01	P	BUTTON FIX - BUTTON						N/A

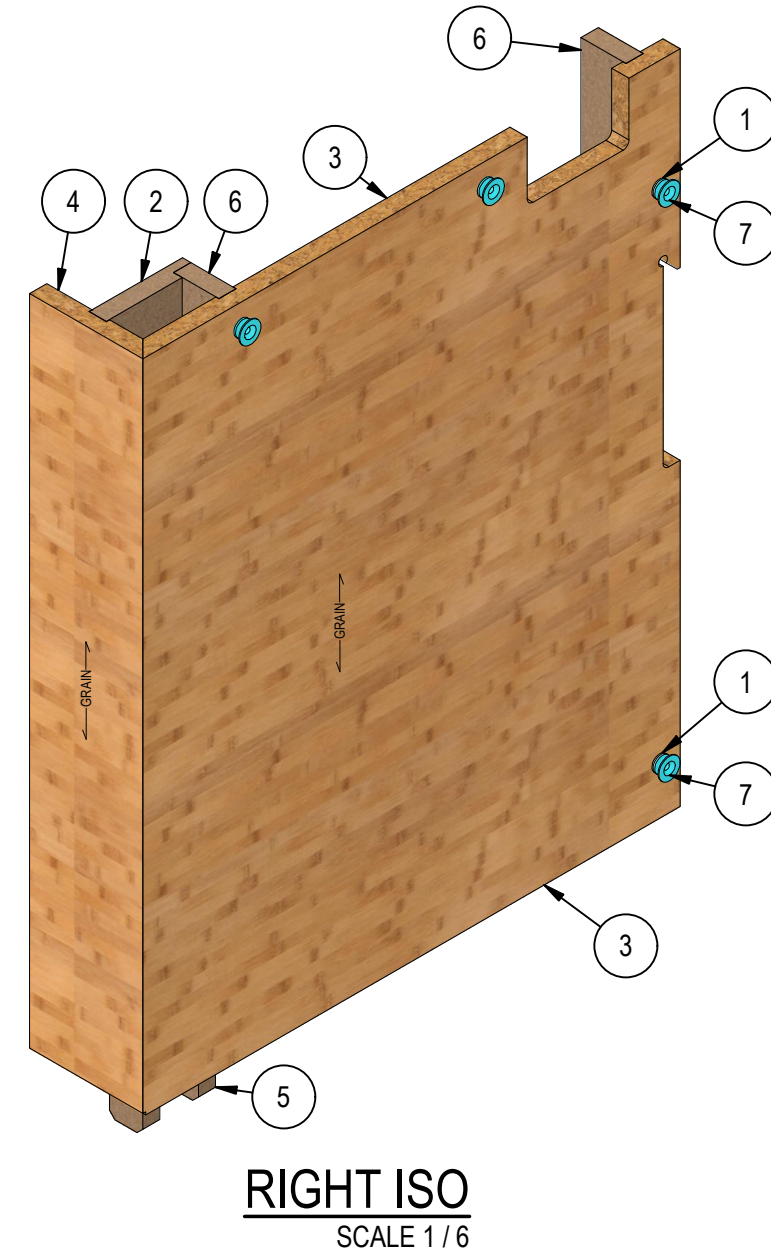
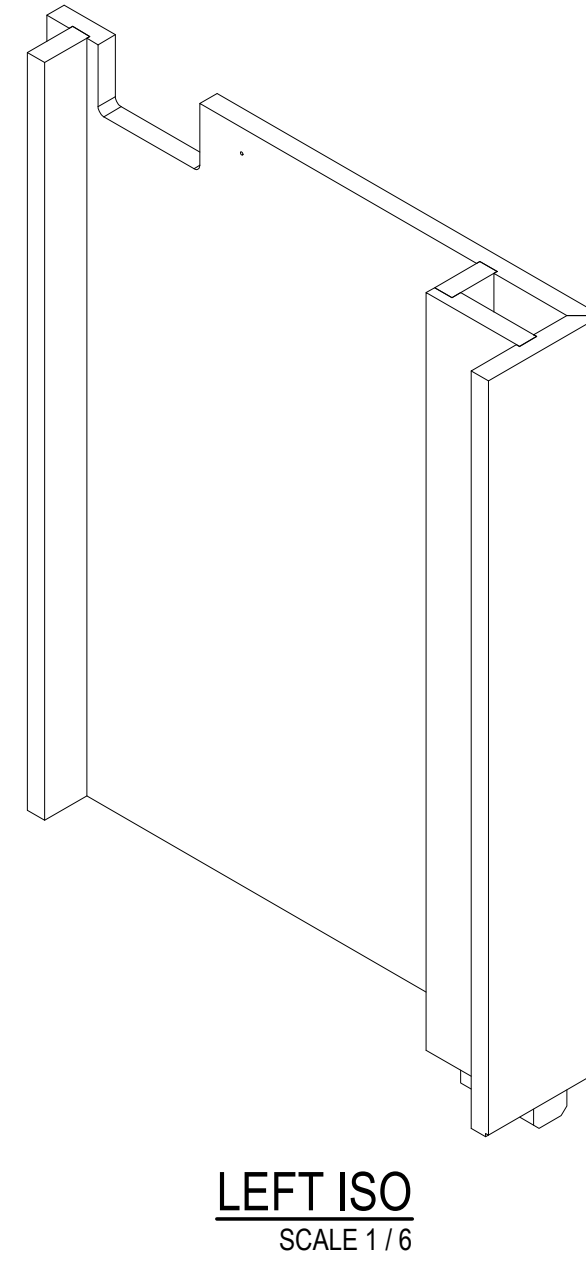
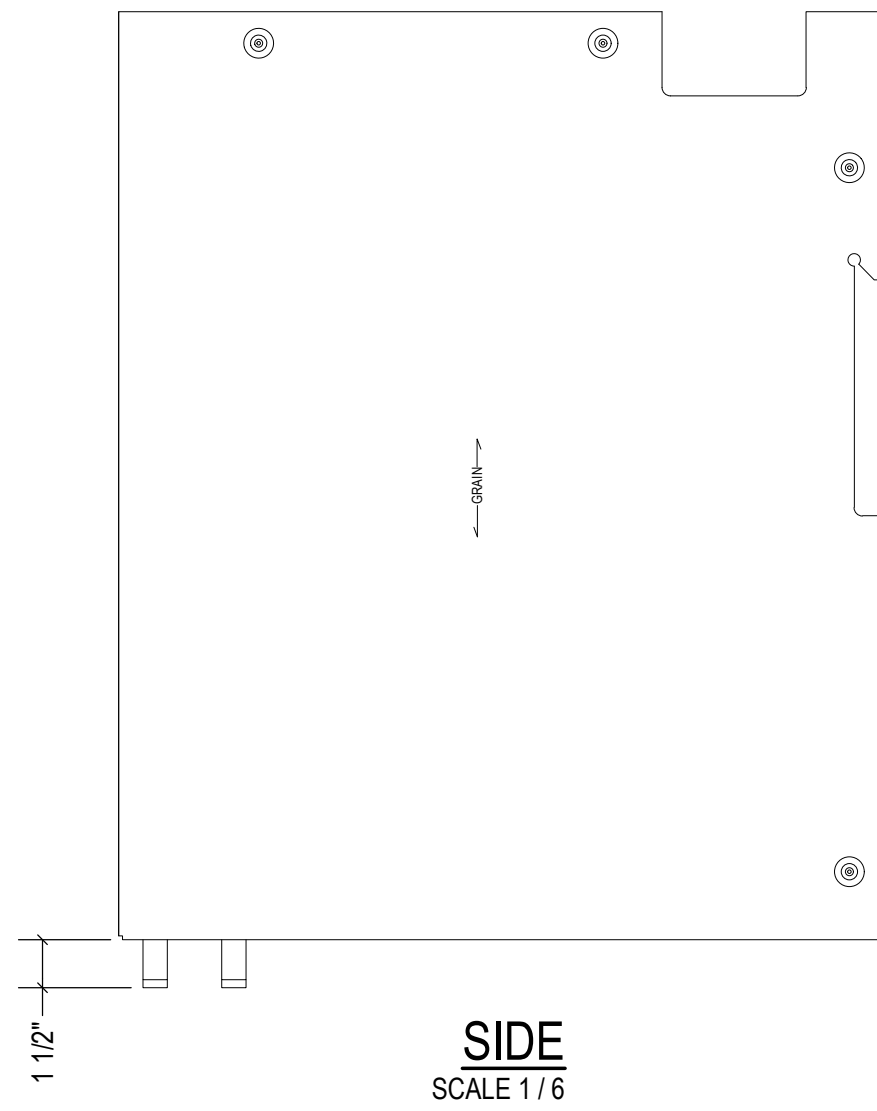
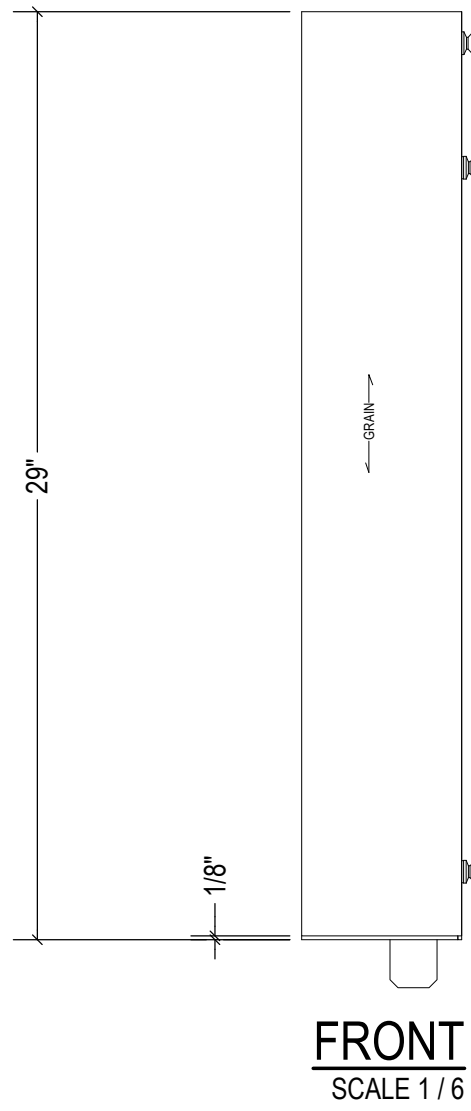
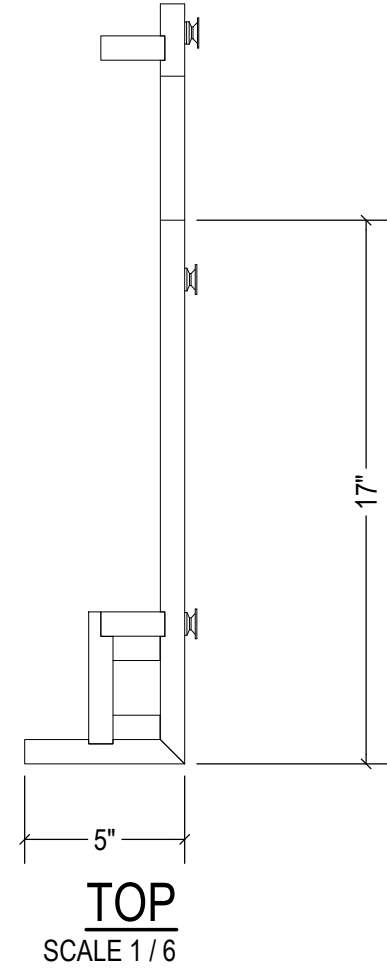

NAPLES BEACH BOUTIQUE
NAPLES, FL

PILASTER - LEFT WING - TOP

DATE: 3/9/2026
DRAWN BY: BH
FIXTURE NAME: BB-01
PART #: 3083-003A-AB
JOB #: 3083
SHEET #: 003.4



3939 WASHINGTON BOULEVARD BALTIMORE, MARYLAND 21227-4165
PH: (410) 242-0400 FX: (410) 242-0475
A DIVISION OF WEITZMAN INDUSTRIES, INC.

- REVISIONS -

BY	DATE	REMARKS

THIS DRAWING REMAINS THE PROPERTY OF DISPLAY CRAFT MFG. CO. THE INFORMATION CONTAINED HEREON IS FOR THE SPECIFIC USE OF THE INDIVIDUAL PROJECT, AND MAY NOT BE USED FOR ANY OTHER PURPOSE WITHOUT THE WRITTEN CONSENT OF DISPLAY CRAFT MFG. CO.

FINISH SCHEDULE	
WD-4	PLYBOO VENEER - CARMELIZED FLAT CUT - 20% SHEEN CLEAR
WD-5	PLYBOO - CARMELIZED FLAT CUT - 20% SHEEN CLEAR
WC-2	PHILLIP JEFFRIES ISLAND - 7867 CAPRI NATURAL
LAM-1	HARD ROCK MAPLE
LT-1	STRIP LIGHTS 3000K

					PARTS LIST						
ITEM	QTY	PART NUMBER	C.C.	DESCRIPTION	Length	Width	Thk.	Material	Finish	EB	
1	1	3083-003A-BA-01	FC	FRONT	92.75	3	0.765	PLYBOO G2S	20% SHEEN CLEAR	N/A	
2	1	3083-003A-BA-02	FC	LEFT W/O CAB	92.75	23.75	0.765	PLYBOO G2S	20% SHEEN CLEAR	N/A	
3	1	3083-003A-BA-03	FC	RIGHT W/ CAB	92.75	23.75	0.765	PLYBOO G2S	20% SHEEN CLEAR	N/A	
4	3	3083-003A-BA-001	FS	SPACER	92.75	2	0.76	Medium Density Fiberboard		N/A	
5	8	BUTTON_FIX-BUTTON-01	P	BUTTON FIX - BUTTON						N/A	

DATE:	3/9/2026
DRAWN BY:	BH
FIXTURE NAME:	BB-01
PART #:	3083-003A-BA
JOB #:	3083
SHEET #:	003.5

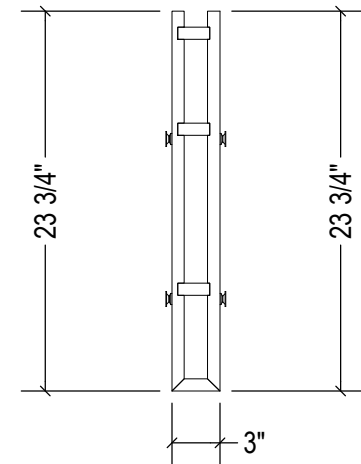

TOP
SCALE 1 / 12

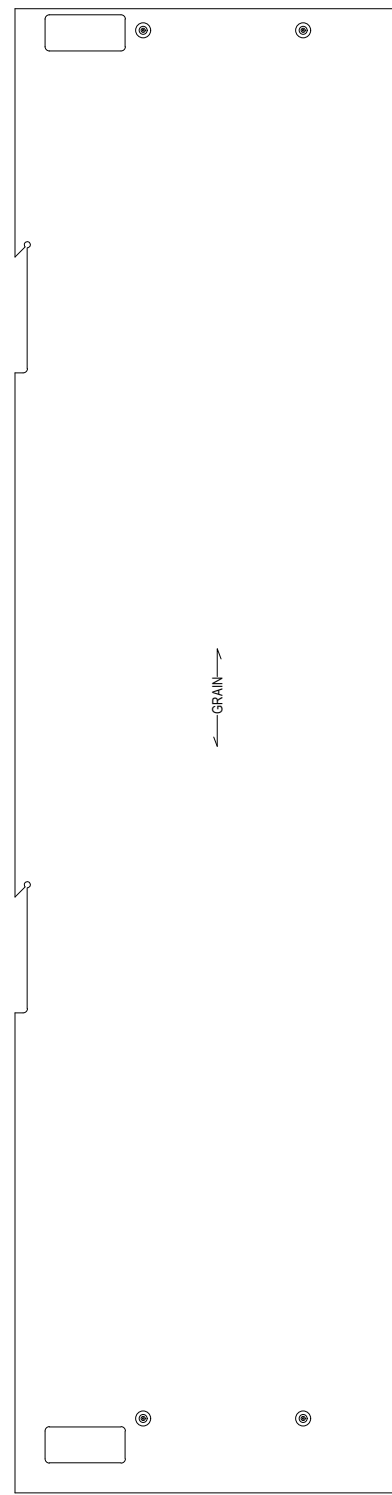

LEFT
SCALE 1 / 12

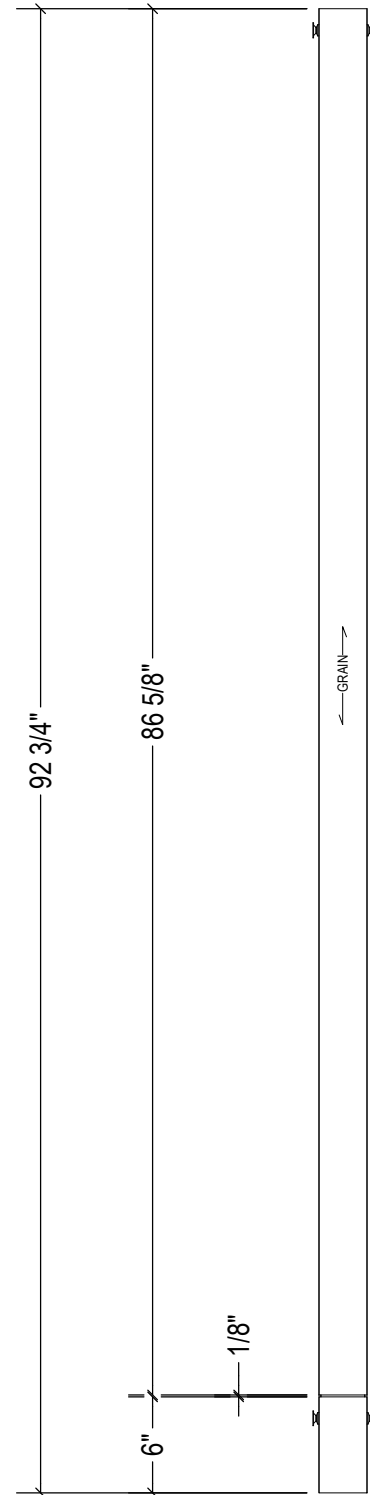

FRONT
SCALE 1 / 12

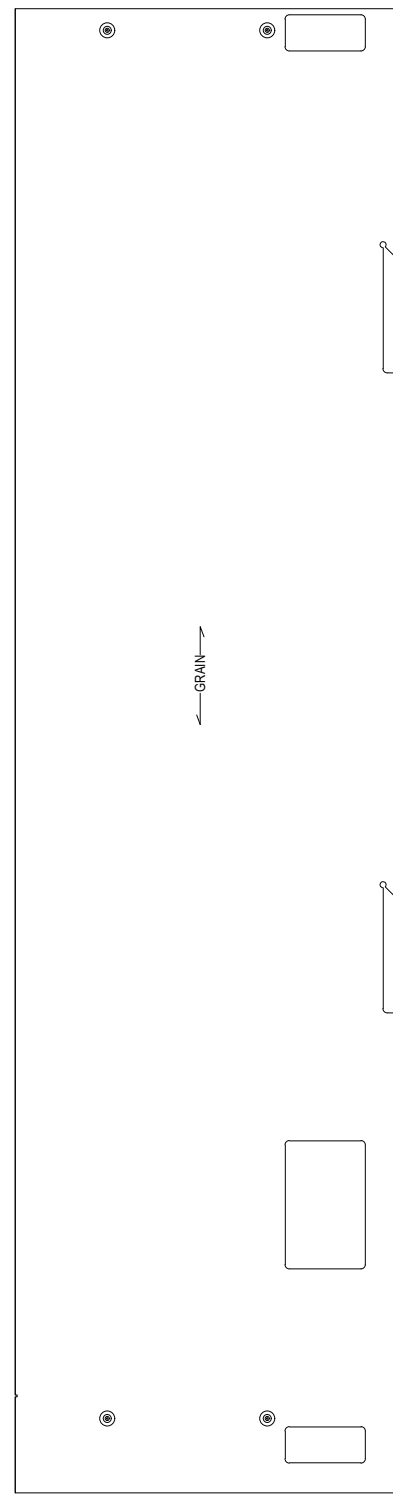

RIGHT
SCALE 1 / 12

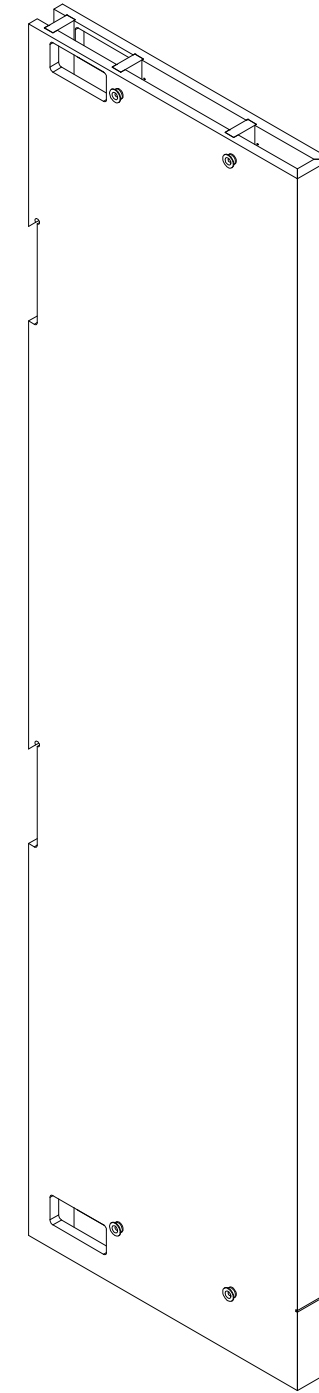

LEFT ISO
SCALE 1 / 12

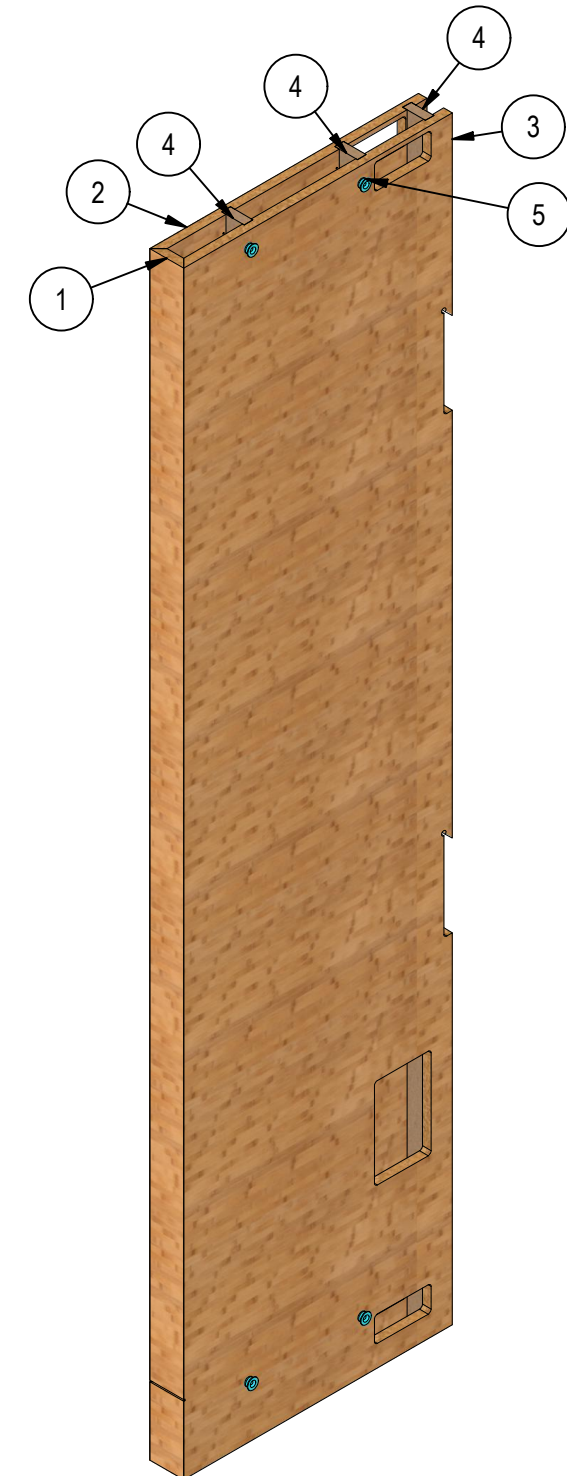

RIGHT ISO
SCALE 1 / 12

NAPLES BEACH BOUTIQUE
NAPLES, FL

PILASTER - CAB RIGHT - OPEN LEFT



3939 WASHINGTON BOULEVARD BALTIMORE, MARYLAND 21227-4165
PH: (410) 242-0400 FX: (410) 242-0475
A DIVISION OF WEITZMAN INDUSTRIES, INC.

- REVISIONS -

BY	DATE	REMARKS

THIS DRAWING REMAINS THE PROPERTY OF DISPLAY CRAFT MFG CO. THE INFORMATION CONTAINED HEREON IS FOR THE SPECIFIC USE OF THE INDIVIDUAL PROJECT, AND MAY NOT BE USED FOR ANY OTHER PURPOSE WITHOUT THE WRITTEN CONSENT OF DISPLAY CRAFT MFG. CO.

FINISH SCHEDULE	
WD-4	PLYBOO VENEER - CARMELIZED FLAT CUT - 20% SHEEN CLEAR
WD-5	PLYBOO - CARMELIZED FLAT CUT - 20% SHEEN CLEAR
WC-2	PHILLIP JEFFRIES ISLAND - 7867 CAPRI NATURAL
LAM-1	HARD ROCK MAPLE
LT-1	STRIP LIGHTS 3000K

ITEM	QTY	PART NUMBER	C.C.	DESCRIPTION	PARTS LIST			Material	Finish	EB
					Length	Width	Thk.			
1	1	3083-003-BB-001	FC	LEFT	29	23.75	0.765	PLYBOO G2S	20% SHEEN CLEAR	N/A
2	1	3083-003-BB-002	FC	FRONT	29	3	0.765	PLYBOO G2S	20% SHEEN CLEAR	N/A
3	1	3083-003-BB-003	FC	RIGHT	29	23.75	0.765	PLYBOO G2S	20% SHEEN CLEAR	N/A
4	2	3083-003-BB-005	FM	SPLICE	5.5	1.47	0.76	Medium Density Fiberboard		N/A
5	3	3083-003-BB-004	FS	SPACER	29	2	0.76	Medium Density Fiberboard		N/A
6	8	BUTTON_FIX-BUTTON-01	P	BUTTON FIX - BUTTON						N/A
7	4	90295A150-01	P	NYLON WASHER	0.688	0.688	0.063	Solid Aluminum Piece		N/A

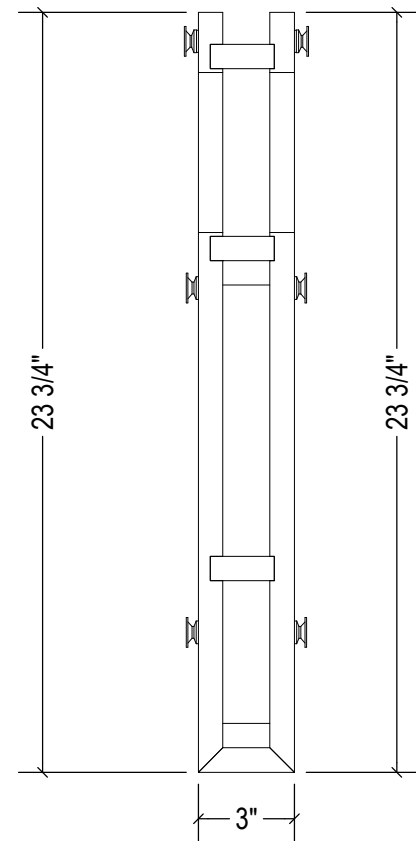

TOP
SCALE 1/6

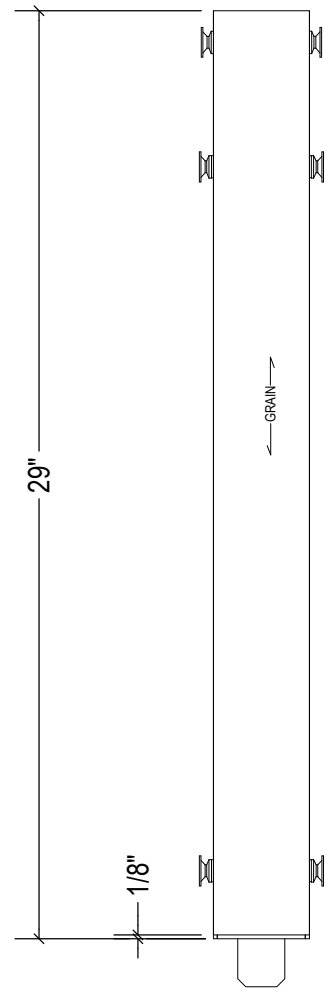

FRONT
SCALE 1/6

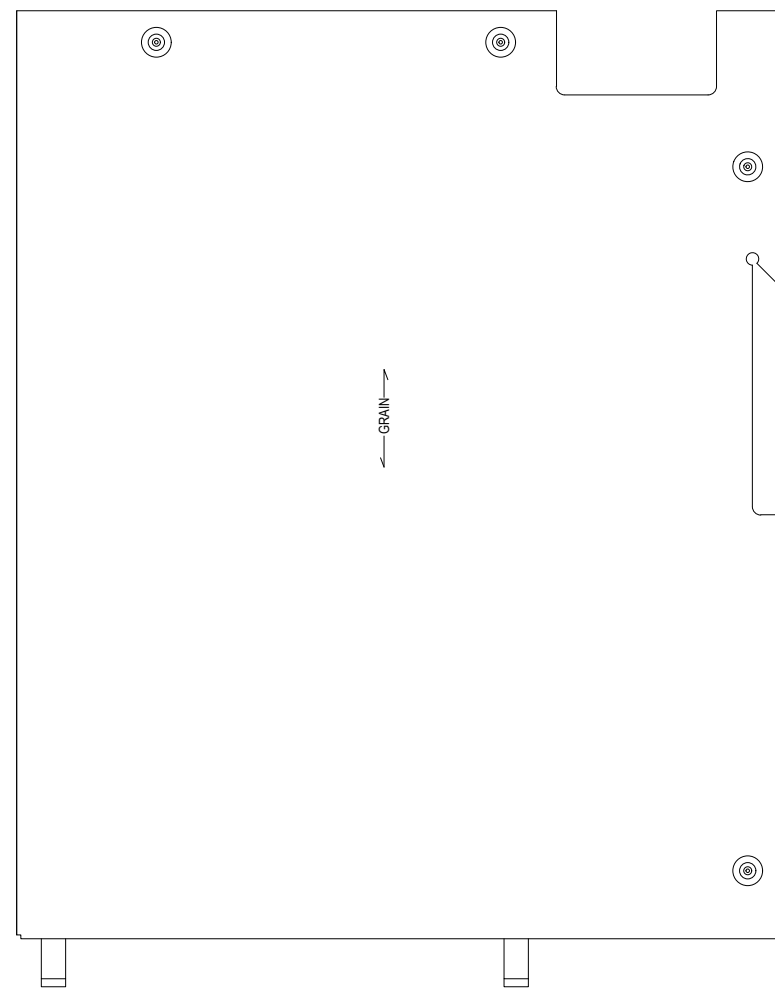

SIDE
SCALE 1/6

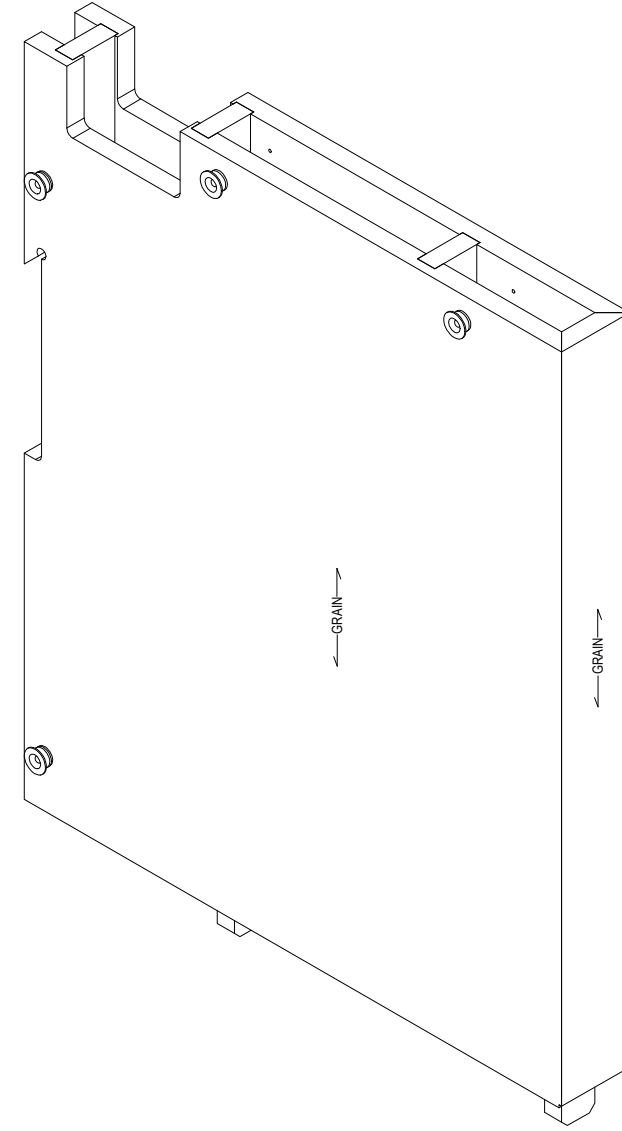

LEFT ISO
SCALE 1/6

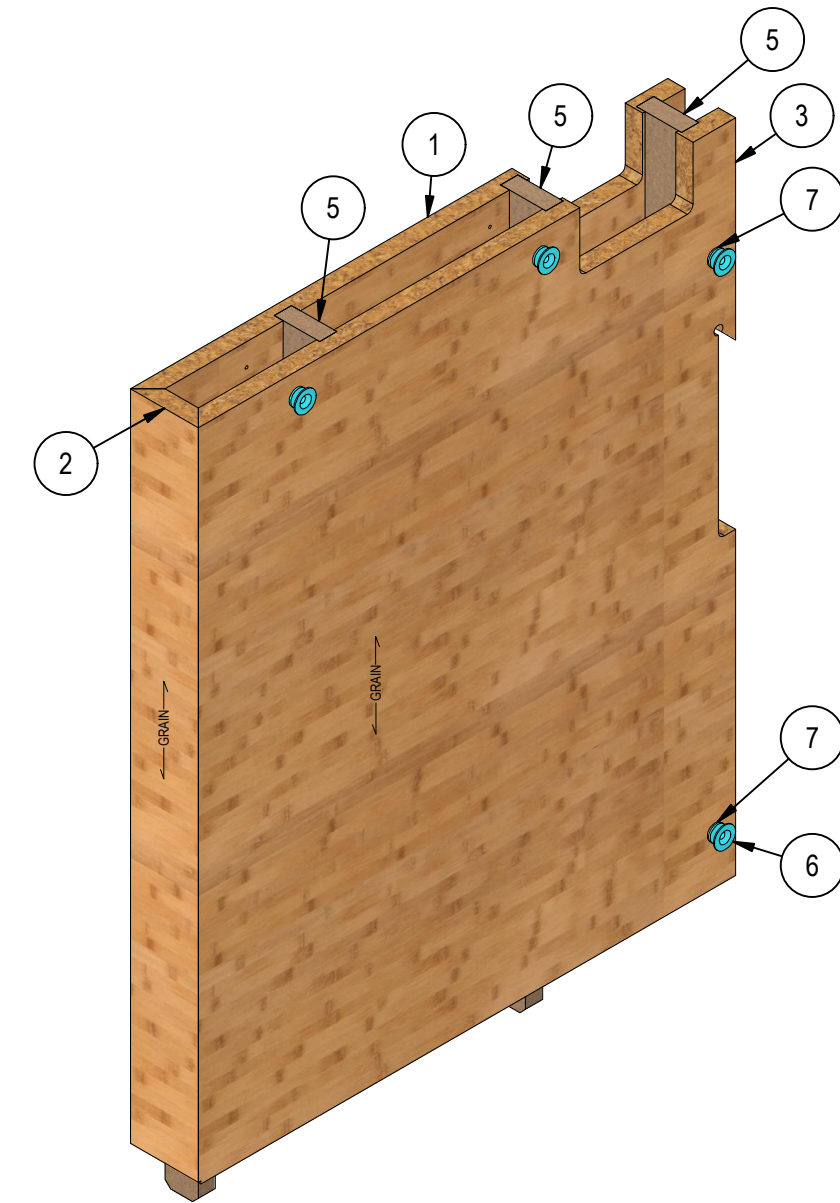

RIGHT ISO
SCALE 1/6

NAPLES BEACH BOUTIQUE
NAPLES, FL

CENTER PILASTER TOP



3939 WASHINGTON BOULEVARD BALTIMORE, MARYLAND 21227-4165
PH: (410) 242-0400 FX: (410) 242-0475
A DIVISION OF WEITZMAN INDUSTRIES, INC.

DATE:	3/9/2026
DRAWN BY:	BH
FIXTURE NAME:	BB-01
PART #:	3083-003-BB
JOB #:	3083
SHEET #:	003.6

- REVISIONS -

BY	DATE	REMARKS

THIS DRAWING REMAINS THE PROPERTY OF DISPLAY CRAFT MFG. CO. THE INFORMATION CONTAINED HEREON IS FOR THE SPECIFIC USE OF THE INDIVIDUAL PROJECT, AND MAY NOT BE USED FOR ANY OTHER PURPOSE WITHOUT THE WRITTEN CONSENT OF DISPLAY CRAFT MFG. CO.

FINISH SCHEDULE	
WD-4	PLYBOO VENEER - CARMELIZED FLAT CUT - 20% SHEEN CLEAR
WD-5	PLYBOO - CARMELIZED FLAT CUT - 20% SHEEN CLEAR
WC-2	PHILLIP JEFFRIES ISLAND - 7867 CAPRI NATURAL
LAM-1	HARD ROCK MAPLE
LT-1	STRIP LIGHTS 3000K

PARTS LIST										
ITEM	QTY	PART NUMBER	C.C.	DESCRIPTION	Length	Width	Thk.	Material	Finish	EB
1	1	3083-003-CA-01	FC	LEFT	92.75	23.75	0.765	PLYBOO G2S	20% SHEEN CLEAR	N/A
2	1	3083-003-CA-02	FC	FRONT	92.75	3	0.765	PLYBOO G2S	20% SHEEN CLEAR	N/A
3	1	3083-003-CA-03	FC	RIGHT	92.75	4.747	0.765	PLYBOO G2S	20% SHEEN CLEAR	N/A
4	2	3083-003-CA-04	FS	SPACER	92.75	2	0.76	Medium Density Fiberboard		N/A
5	4	BUTTON_FIX-BUTTON-01	P	BUTTON FIX - BUTTON						N/A

DATE:	3/9/2026
DRAWN BY:	BH
FIXTURE NAME:	BB-01
PART #:	3083-003-CA
JOB #:	3083
SHEET #:	003.7

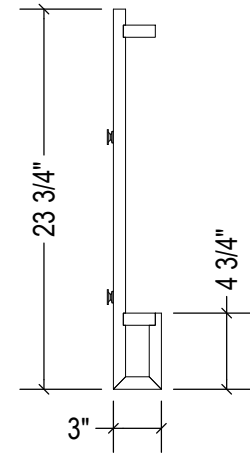

TOP
SCALE 1 / 12

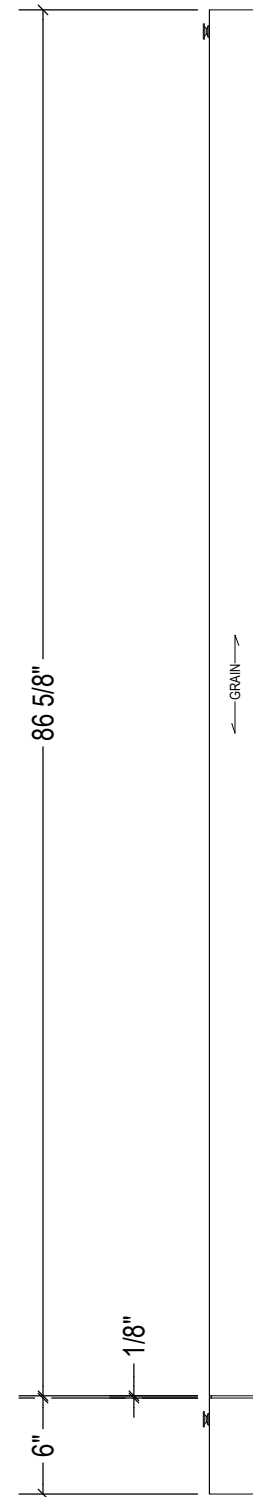

FRONT
SCALE 1 / 12

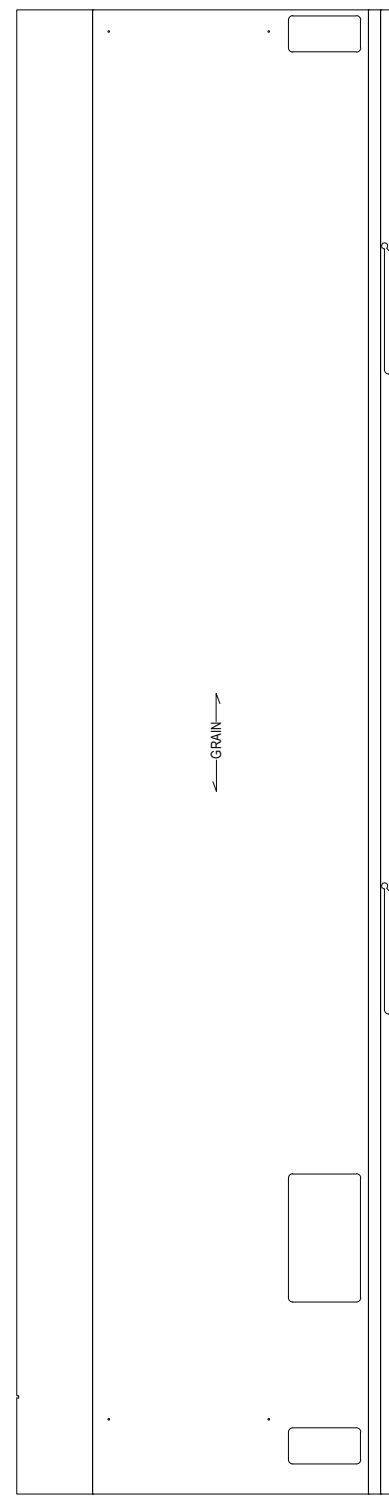

SIDE
SCALE 1 / 12

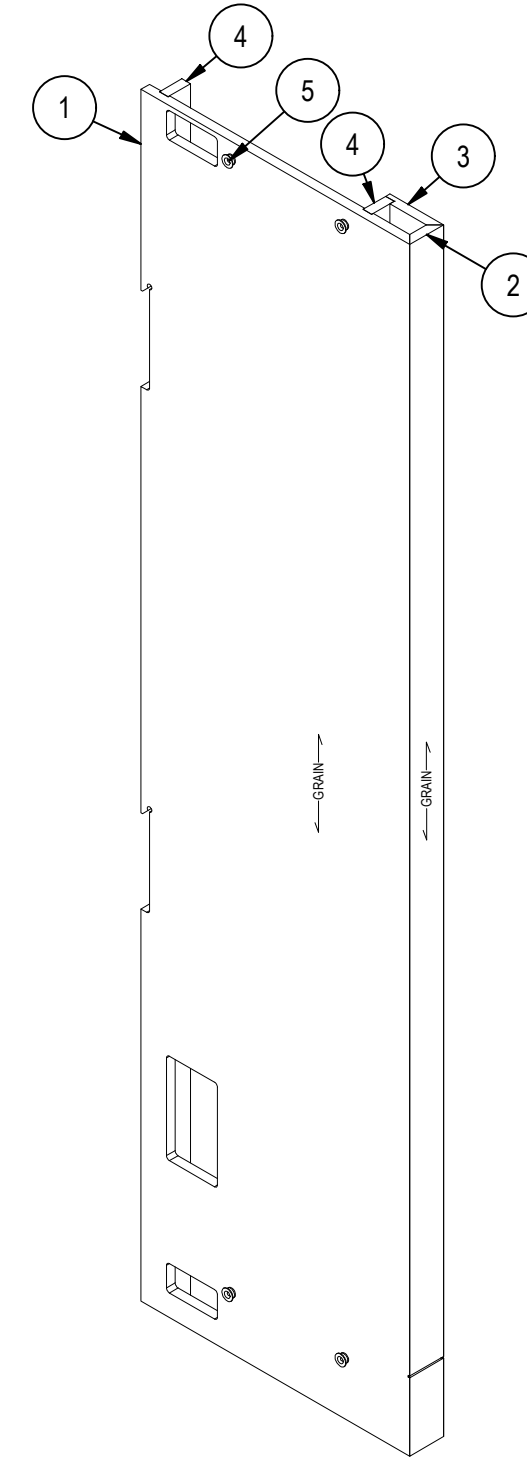

LEFT ISO
SCALE 1 / 12

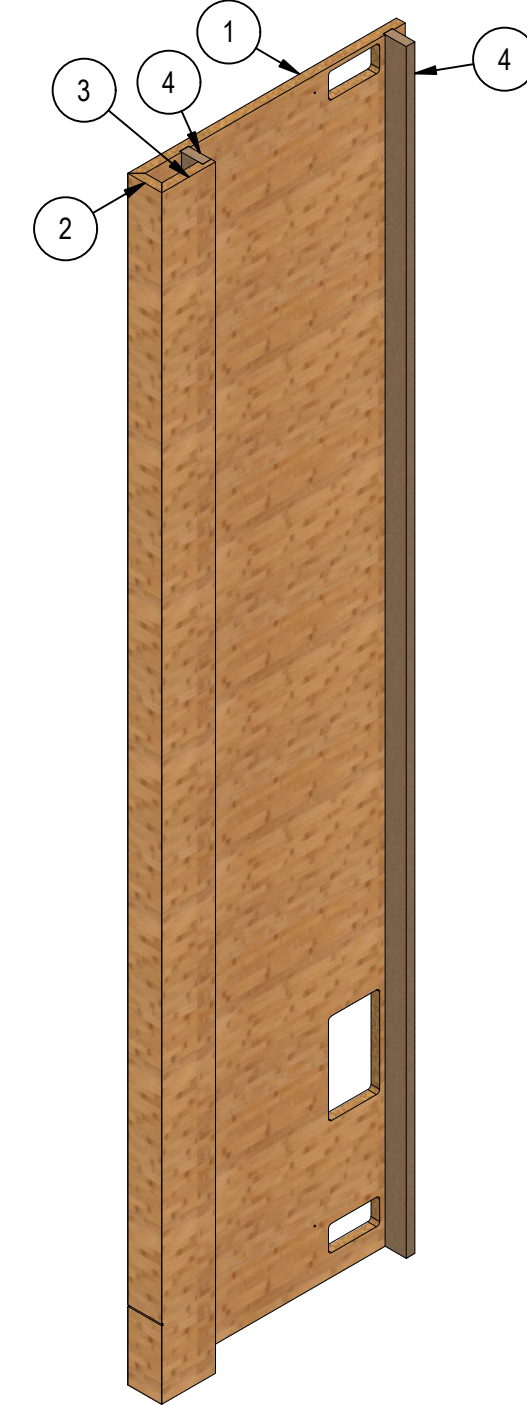

RIGHT ISO
SCALE 1 / 12

NAPLES BEACH BOUTIQUE
NAPLES, FL



3939 WASHINGTON BOULEVARD BALTIMORE, MARYLAND 21227-4165
PH: (410) 242-0400 FX: (410) 242-0475
A DIVISION OF WEITZMAN INDUSTRIES, INC.

RIGHT PILASTER LOWER

Description:

BY	DATE	REMARKS

THIS DRAWING REMAINS THE PROPERTY OF DISPLAY CRAFT MFG CO. THE INFORMATION CONTAINED HEREON IS FOR THE SPECIFIC USE OF THE INDIVIDUAL PROJECT, AND MAY NOT BE USED FOR ANY OTHER PURPOSE WITHOUT THE WRITTEN CONSENT OF DISPLAY CRAFT MFG. CO.

FINISH SCHEDULE	
WD-4	PLYBOO VENEER - CARMELIZED FLAT CUT - 20% SHEEN CLEAR
WD-5	PLYBOO - CARMELIZED FLAT CUT - 20% SHEEN CLEAR
WC-2	PHILLIP JEFFRIES ISLAND - 7867 CAPRI NATURAL
LAM-1	HARD ROCK MAPLE
LT-1	STRIP LIGHTS 3000K

PARTS LIST										
ITEM	QTY	PART NUMBER	C.C.	DESCRIPTION	Length	Width	Thk.	Material	Finish	EB
1	1	3083-003-CB-001	FC	LEFT	29	23.75	0.765	PLYBOO G2S	20% SHEEN CLEAR	N/A
2	1	3083-003-CB-002	FC	FRONT	29	3	0.765	PLYBOO G2S	20% SHEEN CLEAR	N/A
3	1	3083-003-CB-003	FC	SHORT RIGHT	29	4.747	0.765	PLYBOO G2S	20% SHEEN CLEAR	N/A
4	2	3083-003-CB-005	FM	SPLICE	5.5	1.47	0.76	Medium Density Fiberboard		N/A
5	2	3083-003-CB-004	FS	SPACER	29	2	0.76	Medium Density Fiberboard		N/A
6	4	BUTTON_FIX-BUTTON-01	P	BUTTON FIX - BUTTON						N/A
7	2	90295A150-01	P	NYLON WASHER	0.688	0.688	0.063	Solid Aluminum Piece		N/A

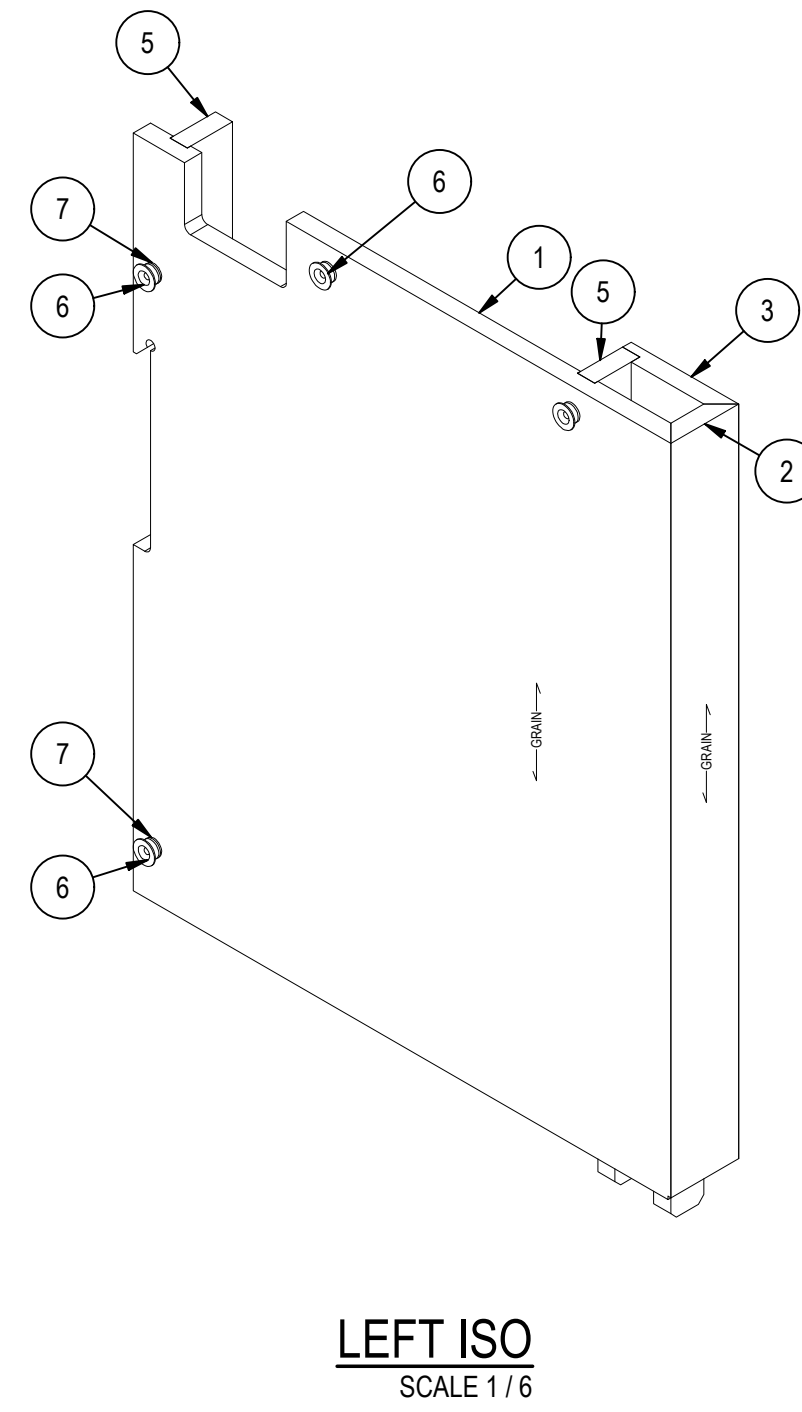
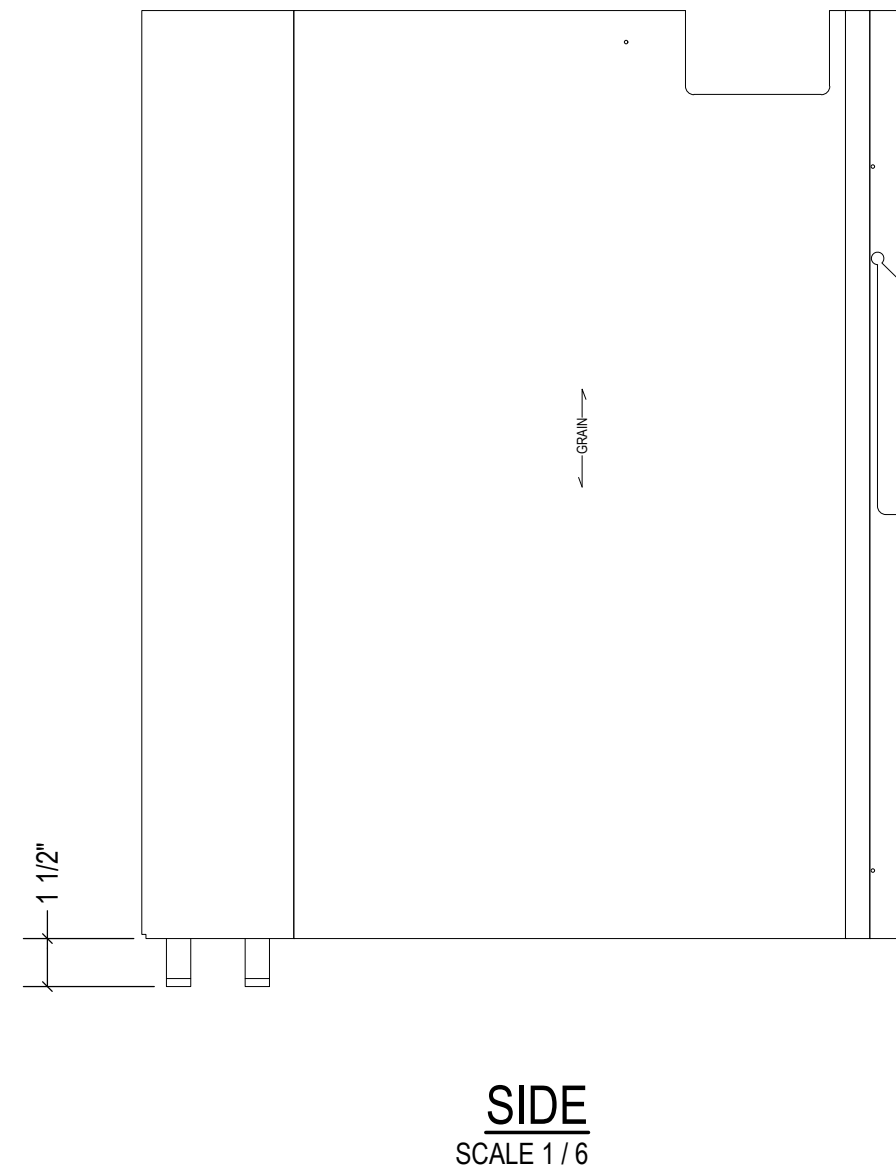
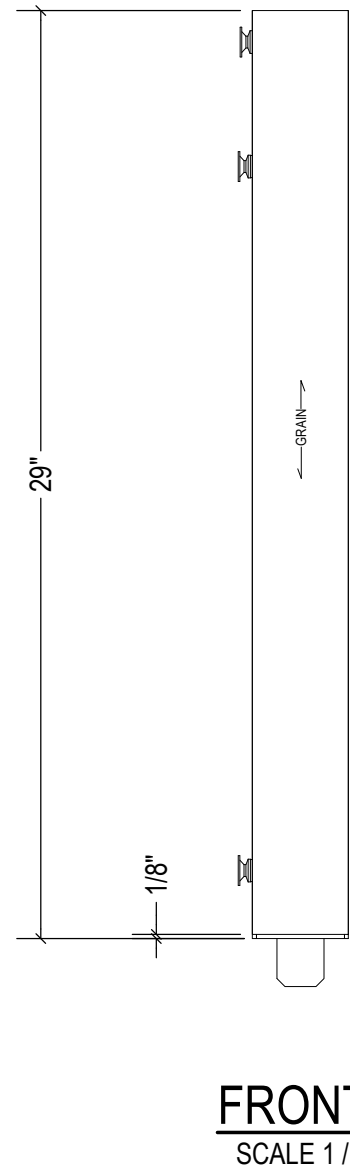
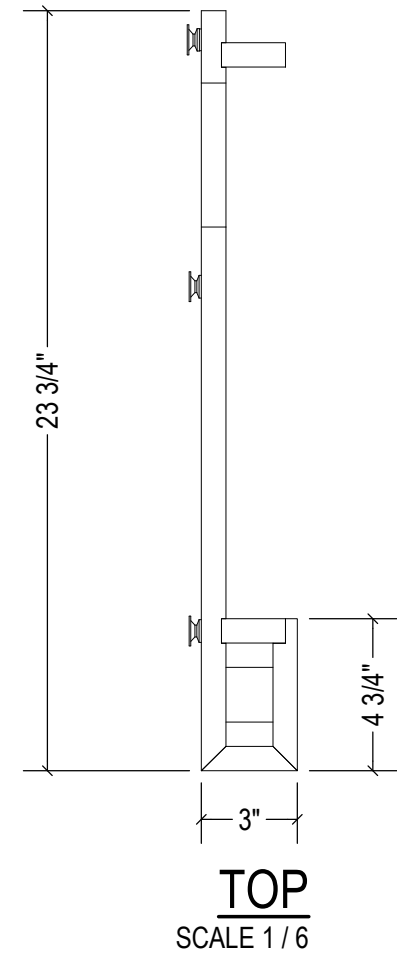

DATE:	3/9/2026
DRAWN BY:	BH
FIXTURE NAME:	BB-01
PART #:	3083-003-CB
JOB #:	3083
SHEET #:	003.8

NAPLES BEACH BOUTIQUE
NAPLES, FL

RIGHT PILASTER TOP



3939 WASHINGTON BOULEVARD BALTIMORE, MARYLAND 21227-4165
PH: (410) 242-0400 FX: (410) 242-0475
A DIVISION OF WEITZMAN INDUSTRIES, INC.

- REVISIONS -

BY	DATE	REMARKS

THIS DRAWING REMAINS THE PROPERTY OF DISPLAY CRAFT MFG. CO. THE INFORMATION CONTAINED HEREON IS FOR THE SPECIFIC USE OF THE INDIVIDUAL PROJECT, AND MAY NOT BE USED FOR ANY OTHER PURPOSE WITHOUT THE WRITTEN CONSENT OF DISPLAY CRAFT MFG. CO.

FINISH SCHEDULE	
WD-4	PLYBOO VENEER - CARMELIZED FLAT CUT - 20% SHEEN CLEAR
WD-5	PLYBOO - CARMELIZED FLAT CUT - 20% SHEEN CLEAR
WC-2	PHILLIP JEFFRIES ISLAND - 7867 CAPRI NATURAL
LAM-1	HARD ROCK MAPLE
LT-1	STRIP LIGHTS 3000K

**REPEAT FROM BB-03
NO ADDITIONAL WALL CLEATS REQUIRED**

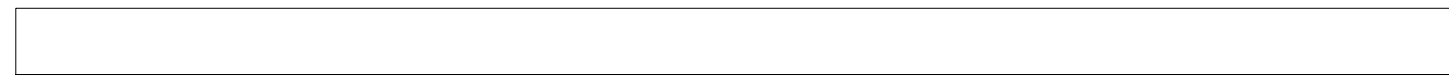

VIEW44
SCALE 1 / 16



VIEW45
SCALE 1 / 16

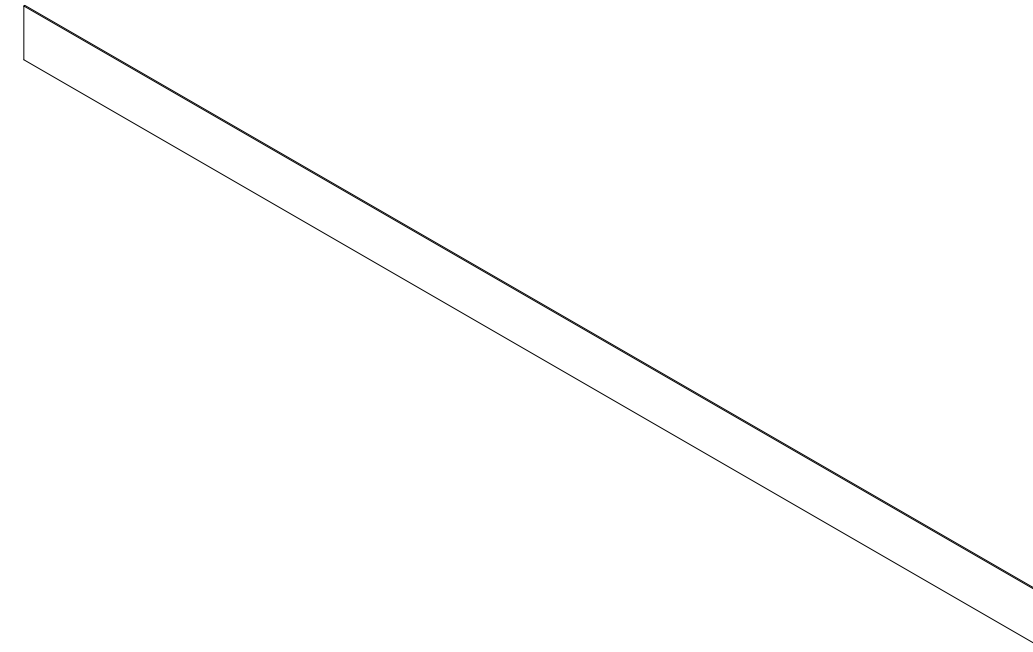

VIEW46
SCALE 1 / 16

**NAPLES BEACH BOUTIQUE
NAPLES, FL**

WALL CLEAT



DATE:	3/9/2026
DRAWN BY:	BH
FIXTURE NAME:	BB-01
PART #:	3083-003-D
JOB #:	3083
SHEET #:	003.9

- REVISIONS -	
BY	REMARKS

THIS DRAWING REMAINS THE PROPERTY OF DISPLAY CRAFT MFG. CO. THE INFORMATION CONTAINED HEREON IS FOR THE SPECIFIC USE OF THE INDIVIDUAL PROJECT, AND MAY NOT BE USED FOR ANY OTHER PURPOSE WITHOUT THE WRITTEN CONSENT OF DISPLAY CRAFT MFG. CO.

FINISH SCHEDULE	
WD-4	PLYBOO VENEER - CARMELIZED FLAT CUT - 20% SHEEN CLEAR
WD-5	PLYBOO - CARMELIZED FLAT CUT - 20% SHEEN CLEAR
WC-2	PHILLIP JEFFRIES ISLAND - 7867 CAPRI NATURAL
LAM-1	HARD ROCK MAPLE
LT-1	STRIP LIGHTS 3000K

PARTS LIST										
ITEM	QTY	PART NUMBER	C.C.	DESCRIPTION	Length	Width	Thk.	Material	Finish	EB
1	4	3083-003A-E001	FC	DEPTH SUPPORT	20	5.25	0.76	Medium Density Fiberboard		N/A
2	1	3083-003A-E002	FC	WIDTH SUPPORT	44	5.25	0.76	Medium Density Fiberboard		N/A
3	1	3083-003A-E01	FC	FRONT	48	5.875	0.765	PLYBOO G2S	20% SHEEN CLEAR	N/A
4	1	3083-003A-E02	FC	TOP	48	21	0.765	PLYBOO G2S	20% SHEEN CLEAR	N/A
5	4	BUTTON FIX - CLIP	P	BUTTON FIX - CLIP						

DATE:	3/9/2026
DRAWN BY:	BH
FIXTURE NAME:	BB-01
PART #:	3083-003A-E
JOB #:	3083
SHEET #:	003.11

NAPLES BEACH BOUTIQUE
NAPLES, FL

TOE KICK - 48 INCH

Description:



3939 WASHINGTON BOULEVARD BALTIMORE, MARYLAND 21227-4165
PH: (410) 242-0400 FX: (410) 242-0475
A DIVISION OF WEITZMAN INDUSTRIES, INC.

- REVISIONS -

BY	DATE	REMARKS

THIS DRAWING REMAINS THE PROPERTY OF DISPLAY CRAFT MFG. CO. THE INFORMATION CONTAINED HEREON IS FOR THE SPECIFIC USE OF THE INDIVIDUAL PROJECT, AND MAY NOT BE USED FOR ANY OTHER PURPOSE WITHOUT THE WRITTEN CONSENT OF DISPLAY CRAFT MFG. CO.

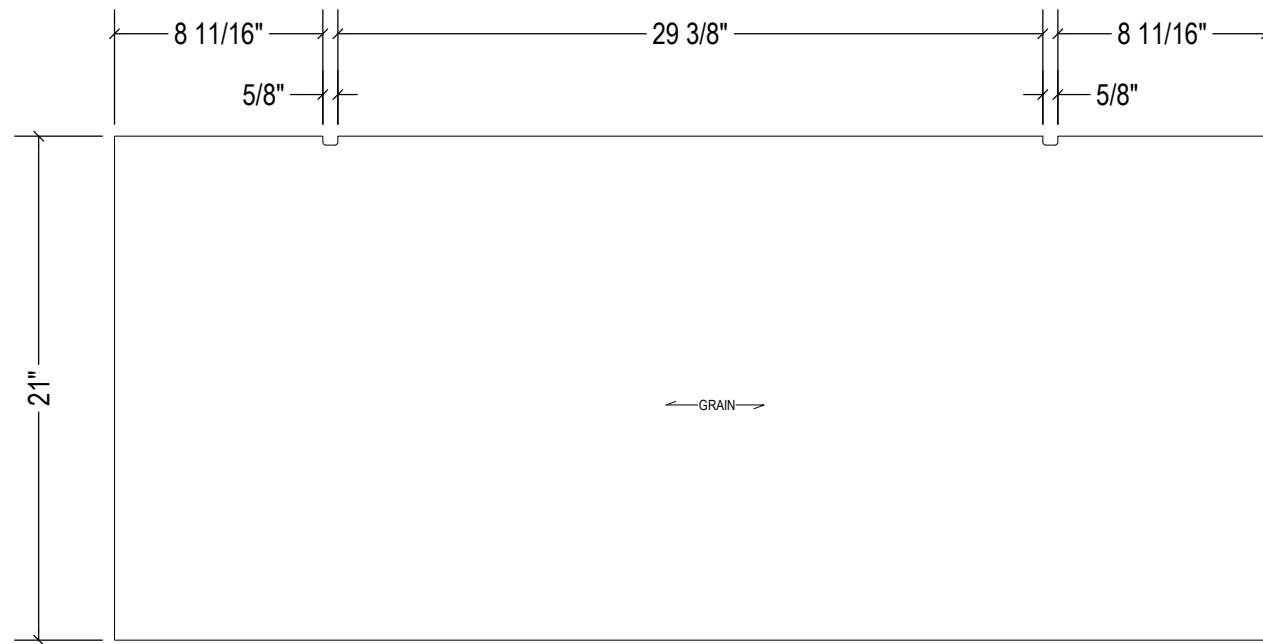
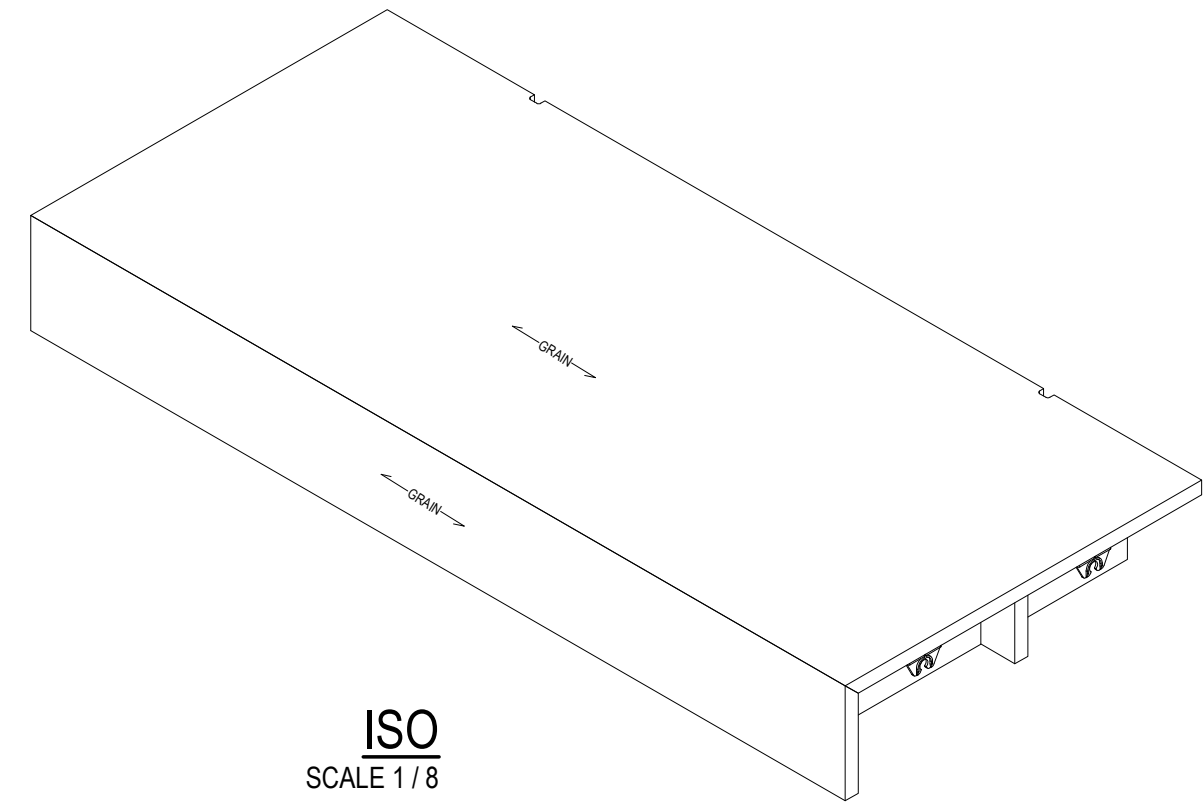

VIEW49
SCALE 1/8

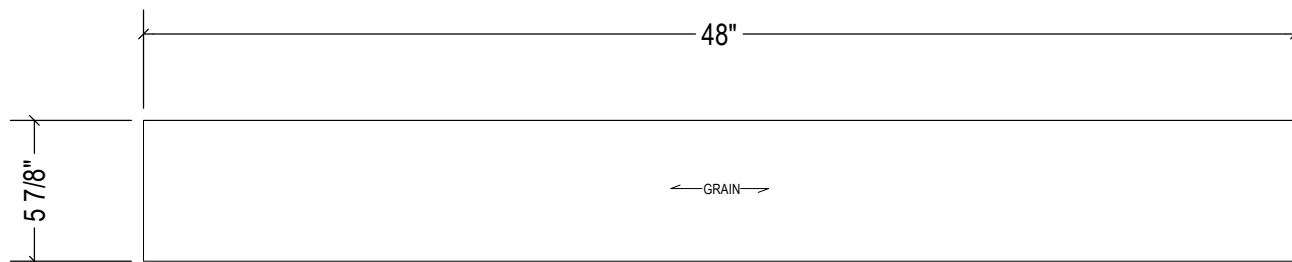

FRONT
SCALE 1/8

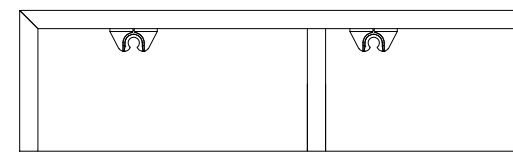

VIEW48
SCALE 1/8

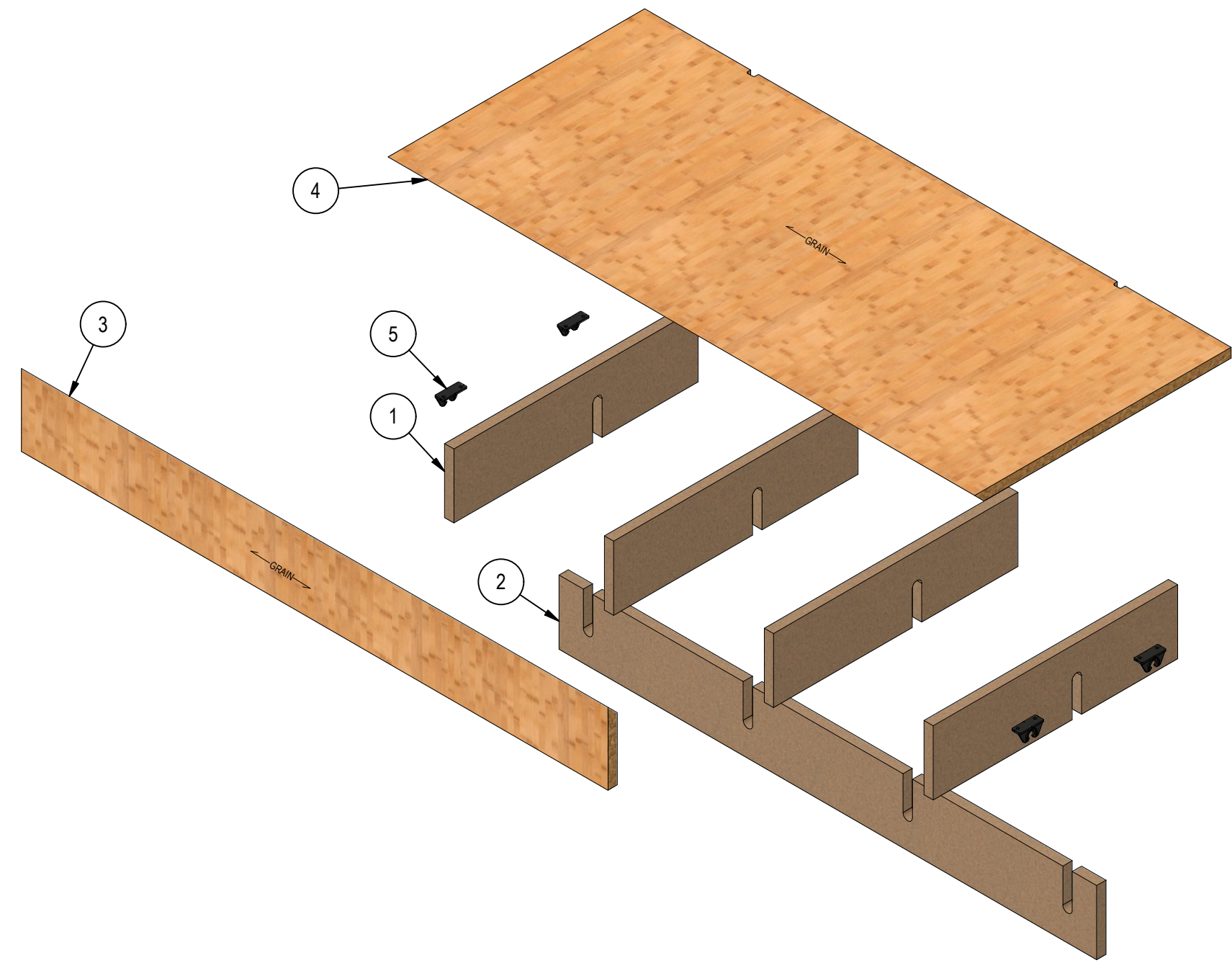

FINISH SCHEDULE	
WD-4	PLYBOO VENEER - CARMELIZED FLAT CUT - 20% SHEEN CLEAR
WD-5	PLYBOO - CARMELIZED FLAT CUT - 20% SHEEN CLEAR
WC-2	PHILLIP JEFFRIES ISLAND - 7867 CAPRI NATURAL
LAM-1	HARD ROCK MAPLE
LT-1	STRIP LIGHTS 3000K

PARTS LIST										
ITEM	QTY	PART NUMBER	C.C.	DESCRIPTION	Length	Width	Thk.	Material	Finish	EB
1	4	3083-003A-F-001	FC	DEPTH SUPPORT	20	5.25	0.76	Medium Density Fiberboard		N/A
2	1	3083-003A-F-002	FC	WIDTH SUPPORT	56	5.25	0.76	Medium Density Fiberboard		N/A
3	1	3083-003A-F-01	FC	FRONT	60	5.875	0.765	PLYBOO G2S	20% SHEEN CLEAR	N/A
4	1	3083-003A-F-02	FC	TOP	60	20.625	0.765	PLYBOO G2S	20% SHEEN CLEAR	N/A
5	4	BUTTON FIX - CLIP	P	BUTTON FIX - CLIP						

DATE:	3/9/2026
DRAWN BY:	BH
FIXTURE NAME:	BB-01
PART #:	3083-003A-F
JOB #:	3083
SHEET #:	003.12

NAPLES BEACH BOUTIQUE
NAPLES, FL

TOE KICK - 60 INCH

Description:



3939 WASHINGTON BOULEVARD BALTIMORE, MARYLAND 21227-4165
PH: (410) 242-0400 FX: (410) 242-0475
A DIVISION OF WEITZMAN INDUSTRIES, INC.

- REVISIONS -

BY	DATE	REMARKS

THIS DRAWING REMAINS THE PROPERTY OF DISPLAY CRAFT MFG. CO. THE INFORMATION CONTAINED HEREON IS FOR THE SPECIFIC USE OF THE INDIVIDUAL PROJECT, AND MAY NOT BE USED FOR ANY OTHER PURPOSE WITHOUT THE WRITTEN CONSENT OF DISPLAY CRAFT MFG. CO.

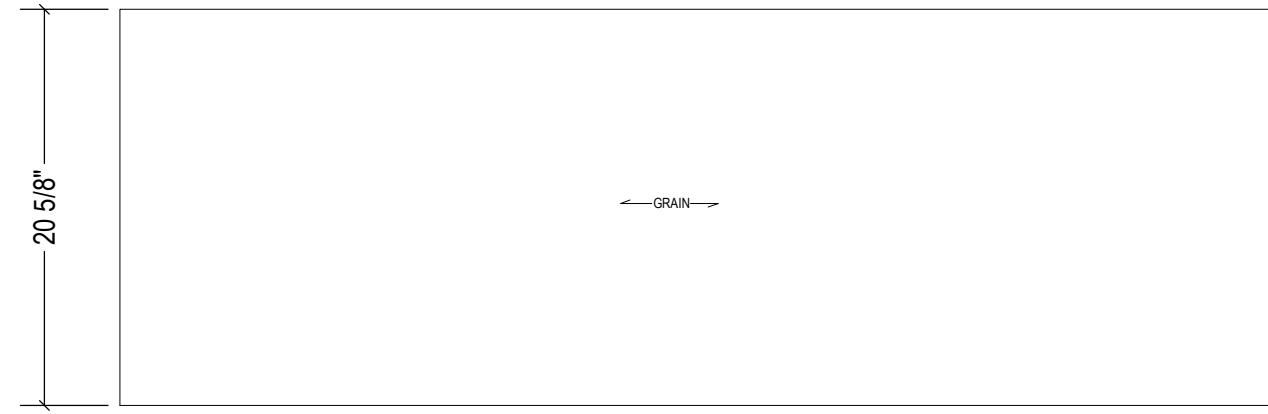

TOP
SCALE 1 / 10

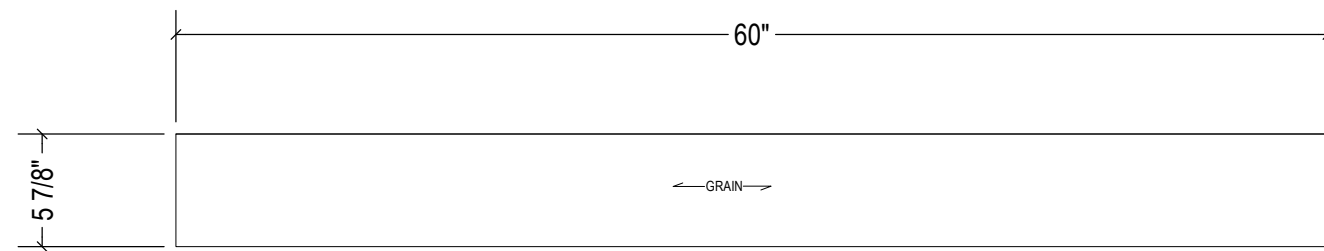

FRONT
SCALE 1 / 10

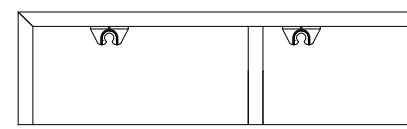

SIDE
SCALE 1 / 10

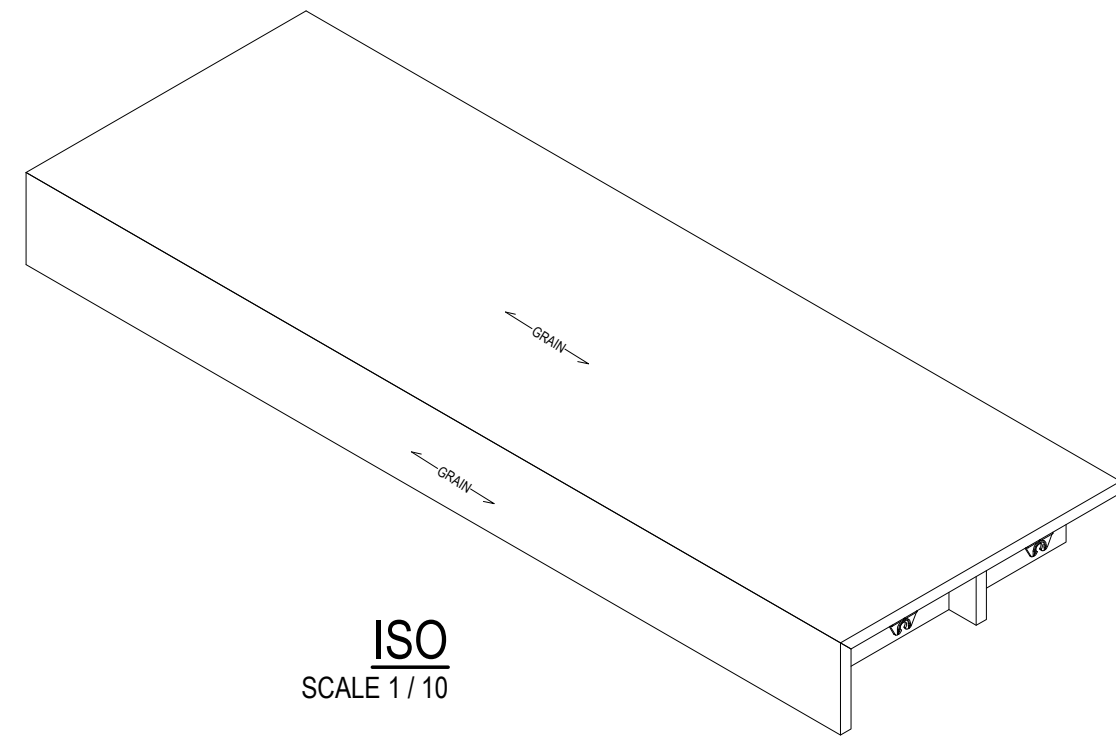

ISO
SCALE 1 / 10

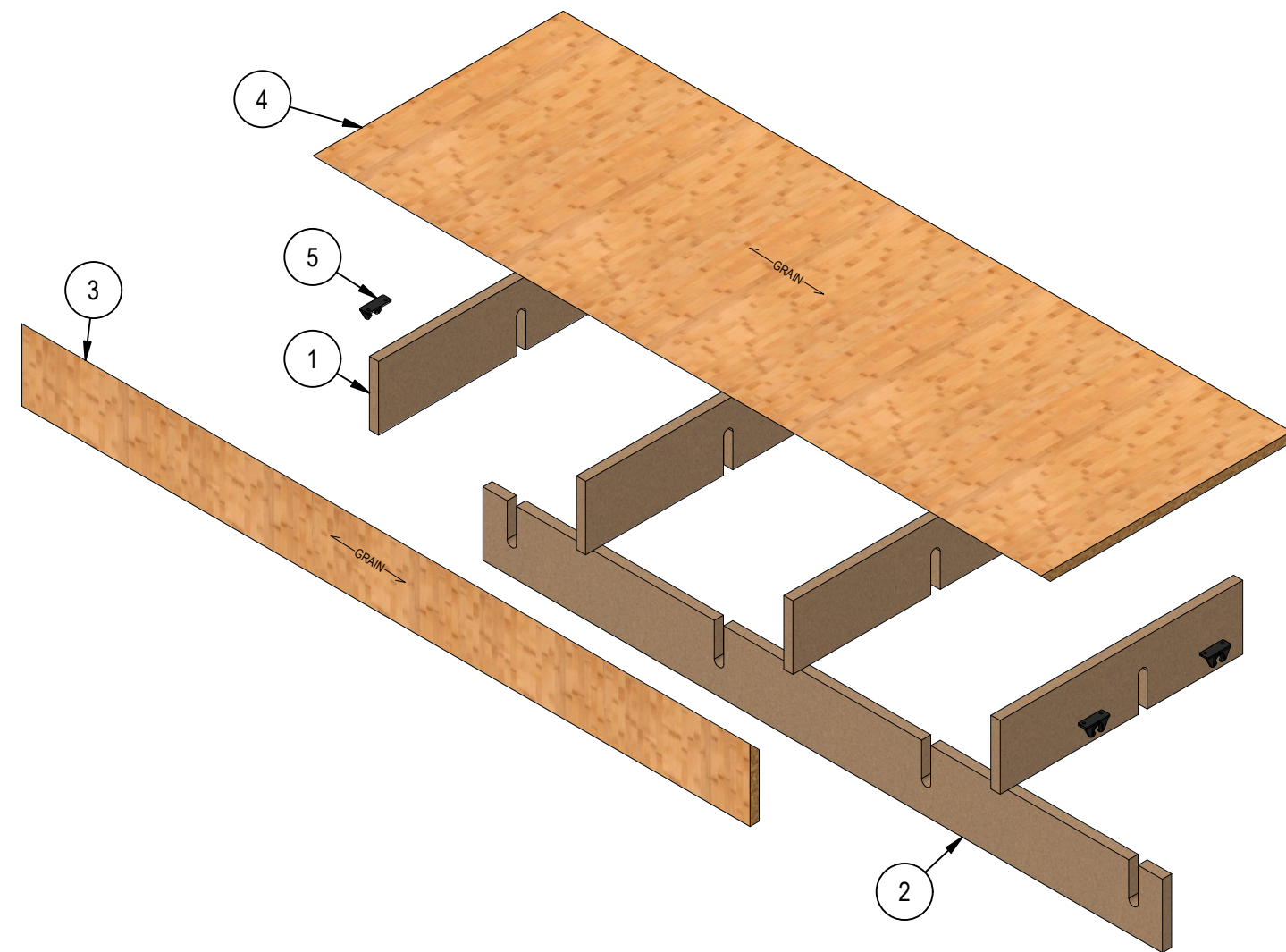

EXPLODED
SCALE 1 / 10

FINISH SCHEDULE	
WD-4	PLYBOO VENEER - CARMELIZED FLAT CUT - 20% SHEEN CLEAR
WD-5	PLYBOO - CARMELIZED FLAT CUT - 20% SHEEN CLEAR
WC-2	PHILLIP JEFFRIES ISLAND - 7867 CAPRI NATURAL
LAM-1	HARD ROCK MAPLE
LT-1	STRIP LIGHTS 3000K

PARTS LIST										
ITEM	QTY	PART NUMBER	C.C.	DESCRIPTION	Length	Width	Thk.	Material	Finish	EB
1	1	3083-003A-G-001	FC	LEFT RISER	19.47	2.125	0.76	Medium Density Fiberboard		N/A
2	1	3083-003A-G-002	FC	RIGHT RISER	19.47	2.125	0.76	Medium Density Fiberboard		N/A
3	1	3083-003A-G-01	FC	FRONT	48	3	0.765	PLYBOO G2S	20% SHEEN CLEAR	N/A
4	1	3083-003A-G-02	FC	BOTTOM	48	21.485	0.256	PLYBOO G2S	20% SHEEN CLEAR	N/A
5	1	3083-003A-G-03	FC	TOP	48	23.75	0.765	PLYBOO G2S	20% SHEEN CLEAR	N/A
6	1	3083-003A-G-04	FC	LED PANEL	48	1.78	0.765	PLYBOO G2S	20% SHEEN CLEAR	N/A
7	1	3083-003A-G-05	FC	LED RISER	48	2.125	0.765	PLYBOO G2S	20% SHEEN CLEAR	N/A
8	2	3083-003A-G-003	FS	STIFFENER	43.505	1.985	0.76	Medium Density Fiberboard		N/A
9	4	BUTTON FIX - CLIP	P	BUTTON FIX - CLIP						
10	3	SELF-MC45-AR01	P	SELF-MC45-AR	1.181	0.45	0.429	Steel Profile		N/A

DATE:	3/9/2026
DRAWN BY:	BH
FIXTURE NAME:	BB-01
PART #:	3083-003A-G
JOB #:	3083
SHEET #:	003.13

**NAPLES BEACH BOUTIQUE
NAPLES, FL**

MID SHELF - 48 INCH

Description:

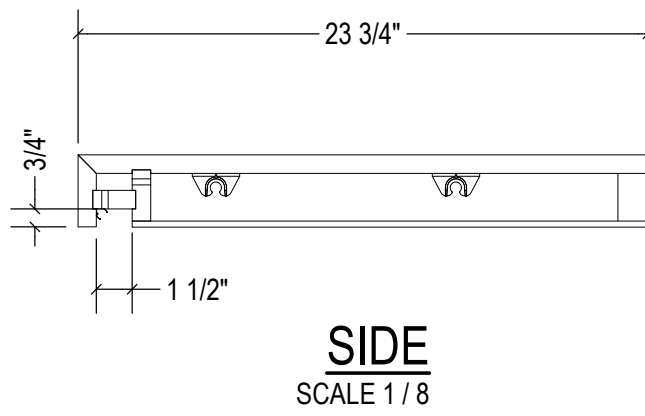
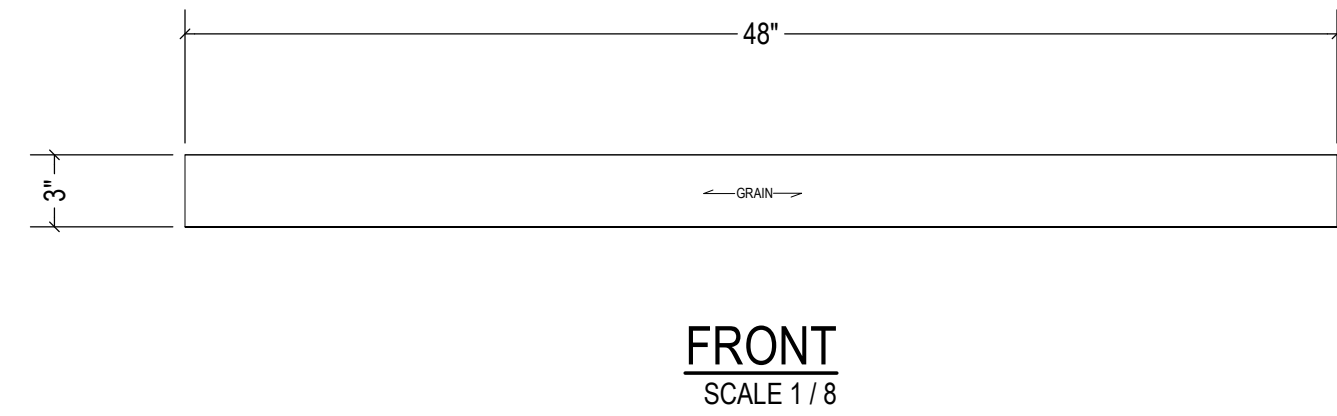
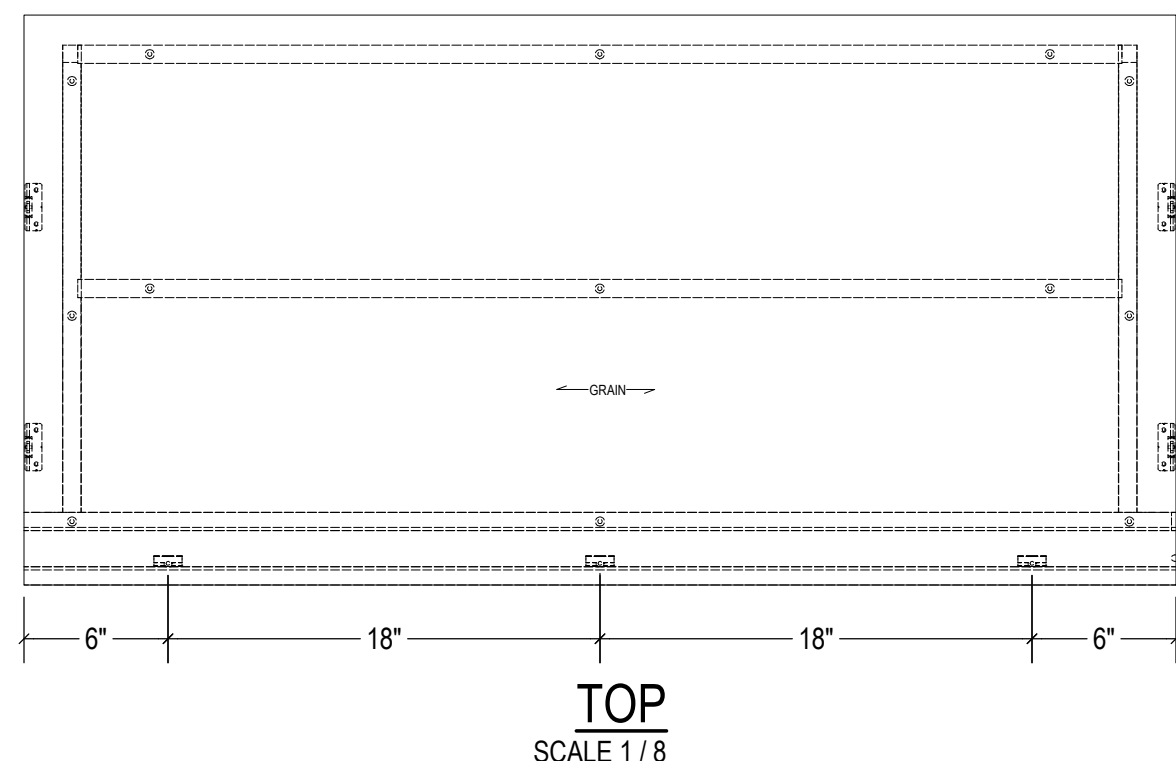

Display Craft
MANUFACTURING CO.

3939 WASHINGTON BOULEVARD BALTIMORE, MARYLAND 21227-4165
PH: (410) 242-0400 FX: (410) 242-0475
A DIVISION OF WEITZMAN INDUSTRIES, INC.

- REVISIONS -

BY	DATE	REMARKS

THIS DRAWING REMAINS THE PROPERTY OF DISPLAY CRAFT MFG. CO. THE INFORMATION CONTAINED HEREON IS FOR THE SPECIFIC USE OF THE INDIVIDUAL PROJECT, AND MAY NOT BE USED FOR ANY OTHER PURPOSE WITHOUT THE WRITTEN CONSENT OF DISPLAY CRAFT MFG. CO.

FINISH SCHEDULE	
WD-4	PLYBOO VENEER - CARMELIZED FLAT CUT - 20% SHEEN CLEAR
WD-5	PLYBOO - CARMELIZED FLAT CUT - 20% SHEEN CLEAR
WC-2	PHILLIP JEFFRIES ISLAND - 7867 CAPRI NATURAL
LAM-1	HARD ROCK MAPLE
LT-1	STRIP LIGHTS 3000K

PARTS LIST										
ITEM	QTY	PART NUMBER	C.C.	DESCRIPTION	Length	Width	Thk.	Material	Finish	EB
1	1	3083-003A-G-001	FC	LEFT RISER	19.47	2.125	0.76	Medium Density Fiberboard		N/A
2	1	3083-003A-G-002	FC	RIGHT RISER	19.47	2.125	0.76	Medium Density Fiberboard		N/A
3	1	3083-003A-G-01	FC	FRONT	48	3	0.765	PLYBOO G2S	20% SHEEN CLEAR	N/A
4	1	3083-003A-G-02	FC	BOTTOM	48	21.485	0.256	PLYBOO G2S	20% SHEEN CLEAR	N/A
5	1	3083-003A-G-03	FC	TOP	48	23.75	0.765	PLYBOO G2S	20% SHEEN CLEAR	N/A
6	1	3083-003A-G-04	FC	LED PANEL	48	1.78	0.765	PLYBOO G2S	20% SHEEN CLEAR	N/A
7	1	3083-003A-G-05	FC	LED RISER	48	2.125	0.765	PLYBOO G2S	20% SHEEN CLEAR	N/A
8	2	3083-003A-G-003	FS	STIFFENER	43.505	1.985	0.76	Medium Density Fiberboard		N/A
9	4	BUTTON FIX - CLIP	P	BUTTON FIX - CLIP						N/A
10	3	SELF-MC45-AR01	P	SELF-MC45-AR	1.181	0.45	0.429	Steel Profile		N/A

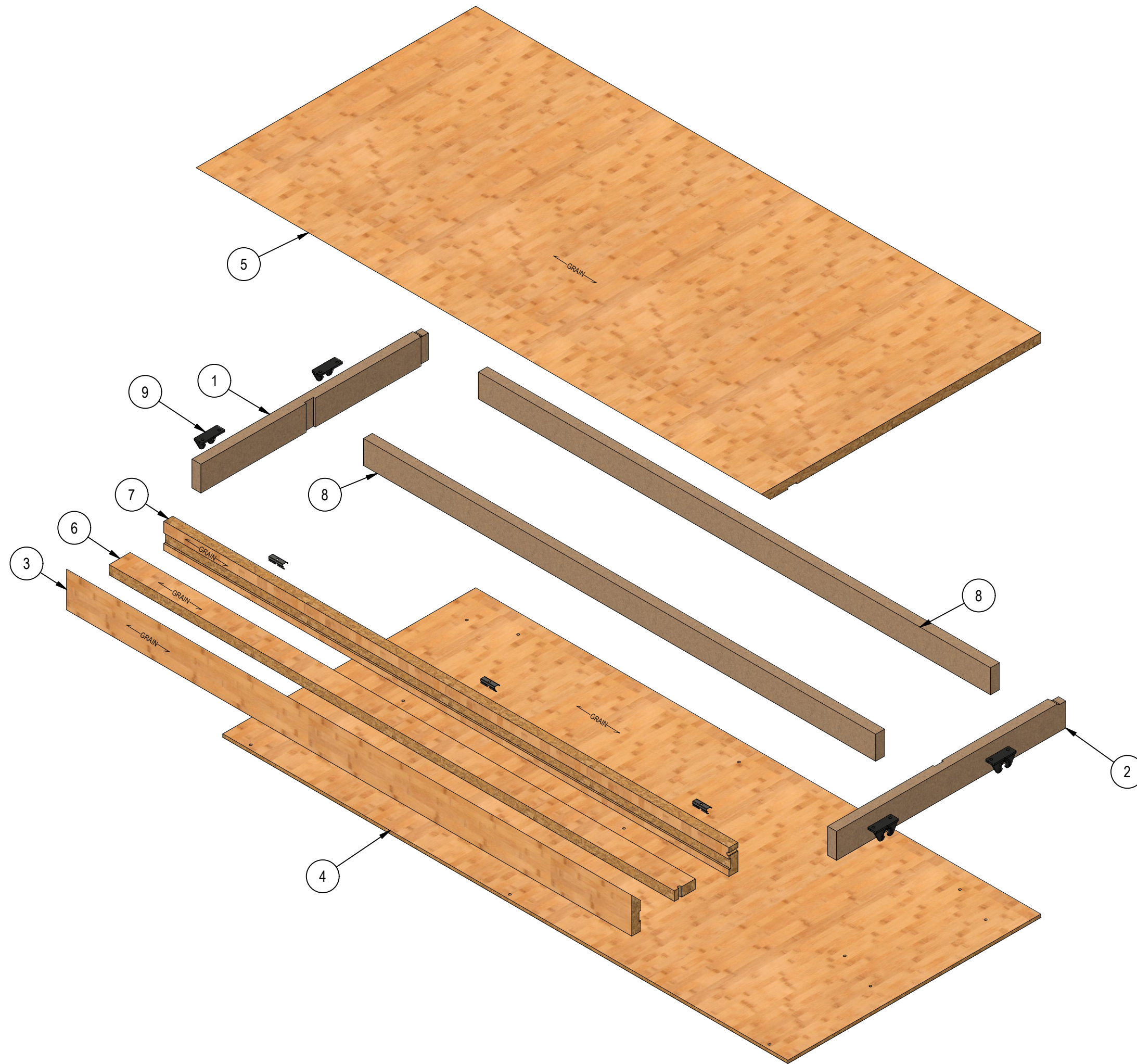

EXPLODED
SCALE 1/6

DATE: 3/9/2026
 DRAWN BY: BH
 FIXTURE NAME: BB-01
 PART #: 3083-003A-G
 JOB #: 3083
 SHEET #: 003.14

NAPLES BEACH BOUTIQUE
NAPLES, FL

MID SHELF - 48 INCH

Description:



3939 WASHINGTON BOULEVARD BALTIMORE, MARYLAND 21227-4165
 PH: (410) 242-0400 FX: (410) 242-0475
 A DIVISION OF WEITZMAN INDUSTRIES, INC.

- REVISIONS -

BY	DATE	REMARKS

THIS DRAWING REMAINS THE PROPERTY OF DISPLAY CRAFT MFG CO. THE INFORMATION CONTAINED HEREON IS FOR THE SPECIFIC USE OF THE INDIVIDUAL PROJECT, AND MAY NOT BE USED FOR ANY OTHER PURPOSE WITHOUT THE WRITTEN CONSENT OF DISPLAY CRAFT MFG. CO.

FINISH SCHEDULE	
WD-4	PLYBOO VENEER - CARMELIZED FLAT CUT - 20% SHEEN CLEAR
WD-5	PLYBOO - CARMELIZED FLAT CUT - 20% SHEEN CLEAR
WC-2	PHILLIP JEFFRIES ISLAND - 7867 CAPRI NATURAL
LAM-1	HARD ROCK MAPLE
LT-1	STRIP LIGHTS 3000K

ITEM	QTY	PART NUMBER	C.C.	DESCRIPTION	PARTS LIST			Material	Finish	EB
					Length	Width	Thk.			
1	1	3083-003A-H-001	FC	LEFT RISER	19.47	2.125	0.76	Medium Density Fiberboard		N/A
2	1	3083-003A-H-002	FC	RIGHT RISER	19.47	2.125	0.76	Medium Density Fiberboard		N/A
3	1	3083-003A-H-01	FC	FRONT	60	3	0.765	PLYBOO G2S	20% SHEEN CLEAR	1L
4	1	3083-003A-H-02	FC	BOTTOM	60	21.485	0.256	PLYBOO G2S	20% SHEEN CLEAR	N/A
5	1	3083-003A-H-03	FC	TOP	60	23.75	0.765	PLYBOO G2S	20% SHEEN CLEAR	N/A
6	1	3083-003A-H-04	FC	LED PANEL	60	1.78	0.765	PLYBOO G2S	20% SHEEN CLEAR	N/A
7	1	3083-003A-H-05	FC	LED RISER	60	2.125	0.765	PLYBOO G2S	20% SHEEN CLEAR	N/A
8	2	3083-003A-H-003	FS	STIFFENER	55.505	1.985	0.76	Medium Density Fiberboard		N/A
9	4	BUTTON FIX - CLIP	P	BUTTON FIX - CLIP						
10	5	SELF-MC45-AR01	P	SELF-MC45-AR	1.181	0.45	0.429	Steel Profile		N/A

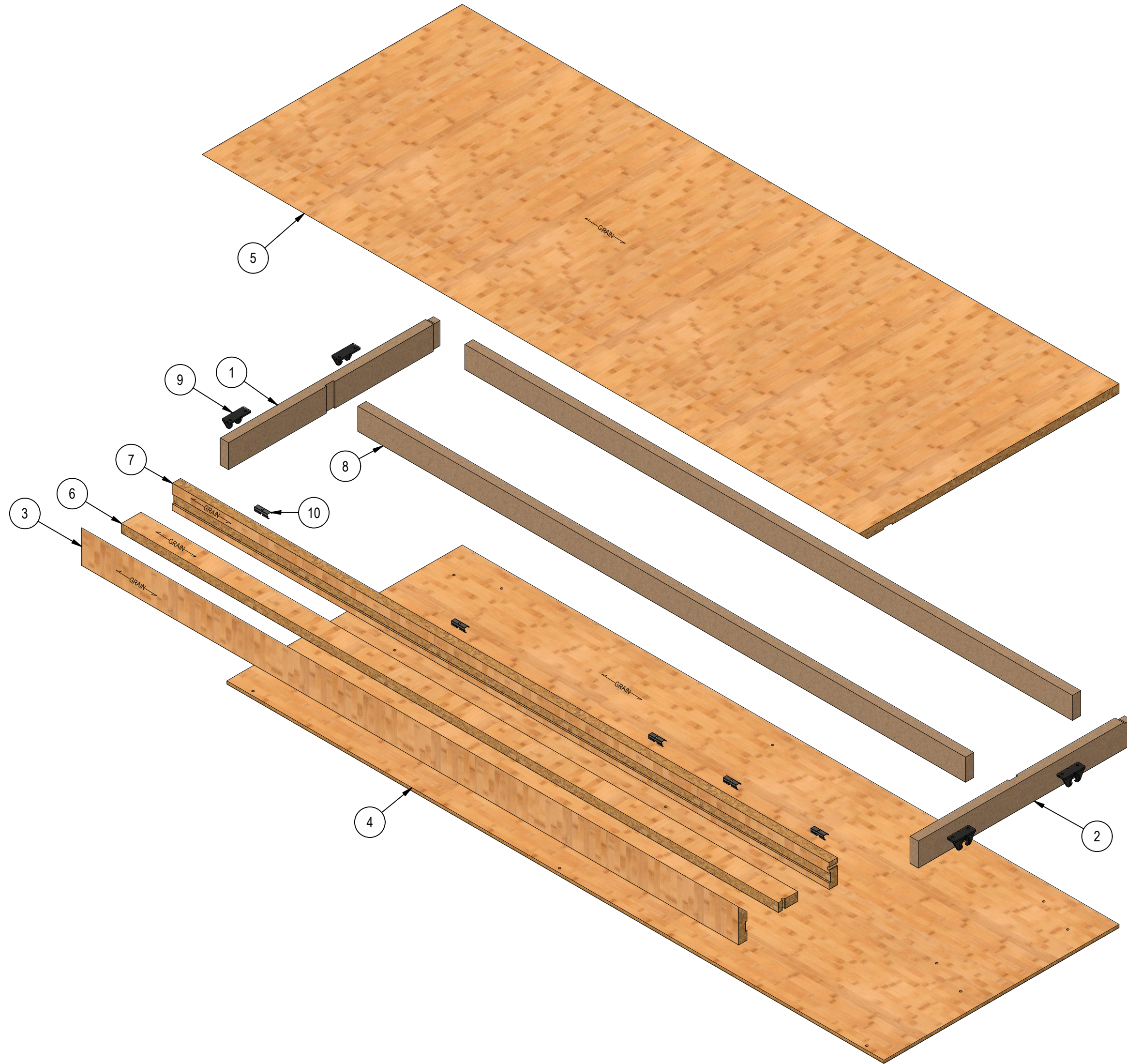

EXPLODED
SCALE 1/6

NAPLES BEACH BOUTIQUE
NAPLES, FL

MID SHELF - 60 INCH



3939 WASHINGTON BOULEVARD BALTIMORE, MARYLAND 21227-4165
PH: (410) 242-0400 FX: (410) 242-0475
A DIVISION OF WEITZMAN INDUSTRIES, INC.

- REVISIONS -

BY	DATE	REMARKS

THIS DRAWING REMAINS THE PROPERTY OF DISPLAY CRAFT MFG. CO. THE INFORMATION CONTAINED HEREON IS FOR THE SPECIFIC USE OF THE INDIVIDUAL PROJECT, AND MAY NOT BE USED FOR ANY OTHER PURPOSE WITHOUT THE WRITTEN CONSENT OF DISPLAY CRAFT MFG. CO.

DATE: 3/9/2026

DRAWN BY: BH

FIXTURE NAME: BB-01

PART #: 3083-003A-H

JOB #: 3083

SHEET #: 003.16

FINISH SCHEDULE	
WD-4	PLYBOO VENEER - CARMELIZED FLAT CUT - 20% SHEEN CLEAR
WD-5	PLYBOO - CARMELIZED FLAT CUT - 20% SHEEN CLEAR
WC-2	PHILLIP JEFFRIES ISLAND - 7867 CAPRI NATURAL
LAM-1	HARD ROCK MAPLE
LT-1	STRIP LIGHTS 3000K

PARTS LIST										
ITEM	QTY	PART NUMBER	C.C.	DESCRIPTION	Length	Width	Thk.	Material	Finish	EB
1	2	3083-003A-J-001	FC	STIFFENER	48	2.125	0.765	Medium Density Fiberboard		N/A
2	1	3083-003A-J-01	FC	FRONT	48	3	0.765	PLYBOO G2S	20% SHEEN CLEAR	1L
3	1	3083-003A-J-02	FC	DECK	48	19.985	0.765	PLYBOO G2S	20% SHEEN CLEAR	1L
4	1	3083-003A-J-03	FC	LED PANEL	48	2.375	0.765	PLYBOO G2S	20% SHEEN CLEAR	N/A
5	4	BUTTON FIX - CLIP	P	BUTTON FIX - CLIP						
6	3	SELF-MC45-AR01	P	SELF-MC45-AR	1.181	0.45	0.429	Steel Profile		N/A

DATE:	3/9/2026
DRAWN BY:	BH
FIXTURE NAME:	BB-01
PART #:	3083-003A-J
JOB #:	3083
SHEET #:	003.17

NAPLES BEACH BOUTIQUE
NAPLES, FL

TOP SHELF - 48 INCH

Description:



3939 WASHINGTON BOULEVARD BALTIMORE, MARYLAND 21227-4165
PH: (410) 242-0400 FX: (410) 242-0475
A DIVISION OF WEITZMAN INDUSTRIES, INC.

- REVISIONS -

BY	DATE	REMARKS

THIS DRAWING REMAINS THE PROPERTY OF DISPLAY CRAFT MFG CO. THE INFORMATION CONTAINED HEREON IS FOR THE SPECIFIC USE OF THE INDIVIDUAL PROJECT, AND MAY NOT BE USED FOR ANY OTHER PURPOSE WITHOUT THE WRITTEN CONSENT OF DISPLAY CRAFT MFG. CO.

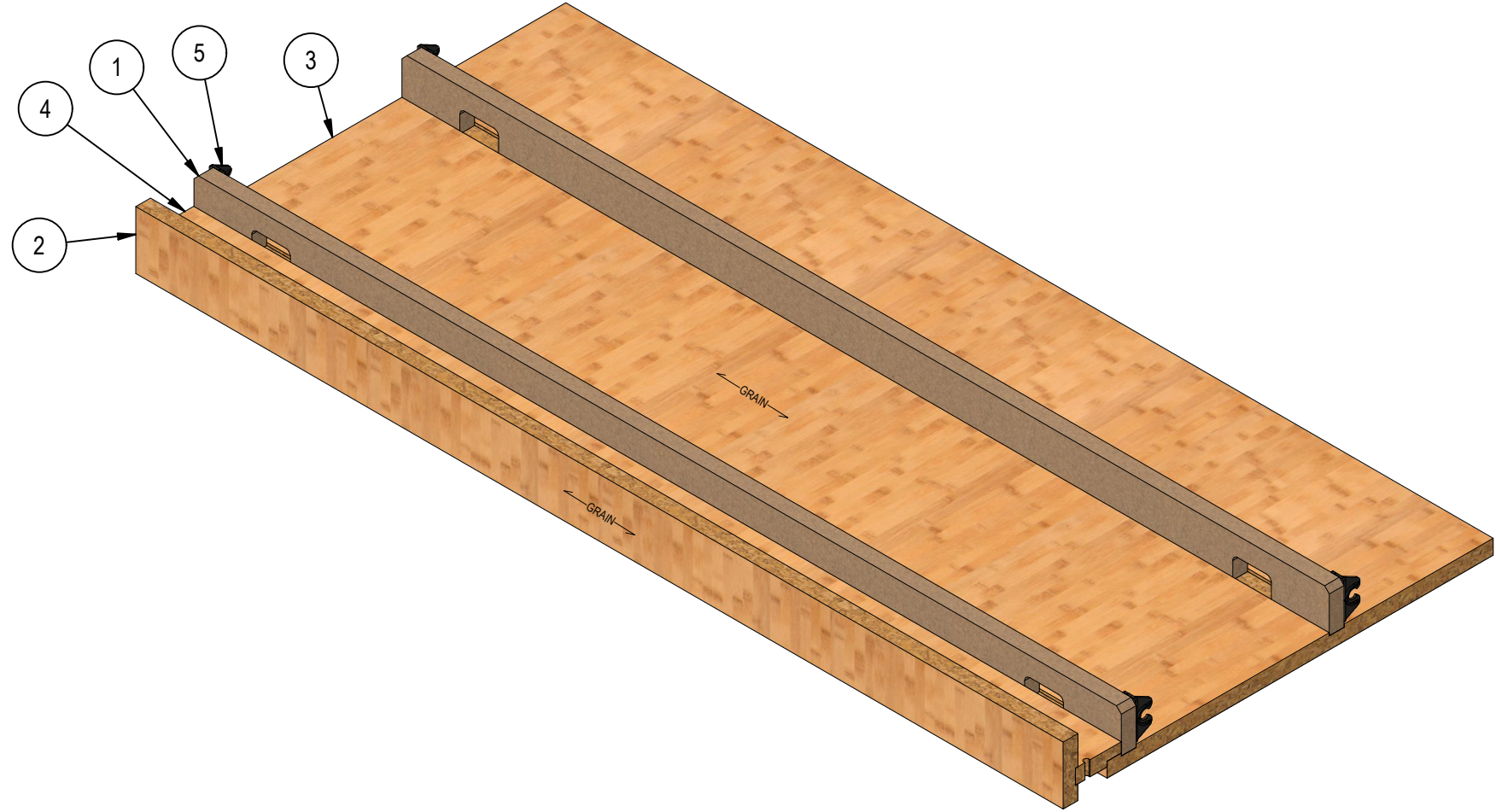

ISO
SCALE 1/6

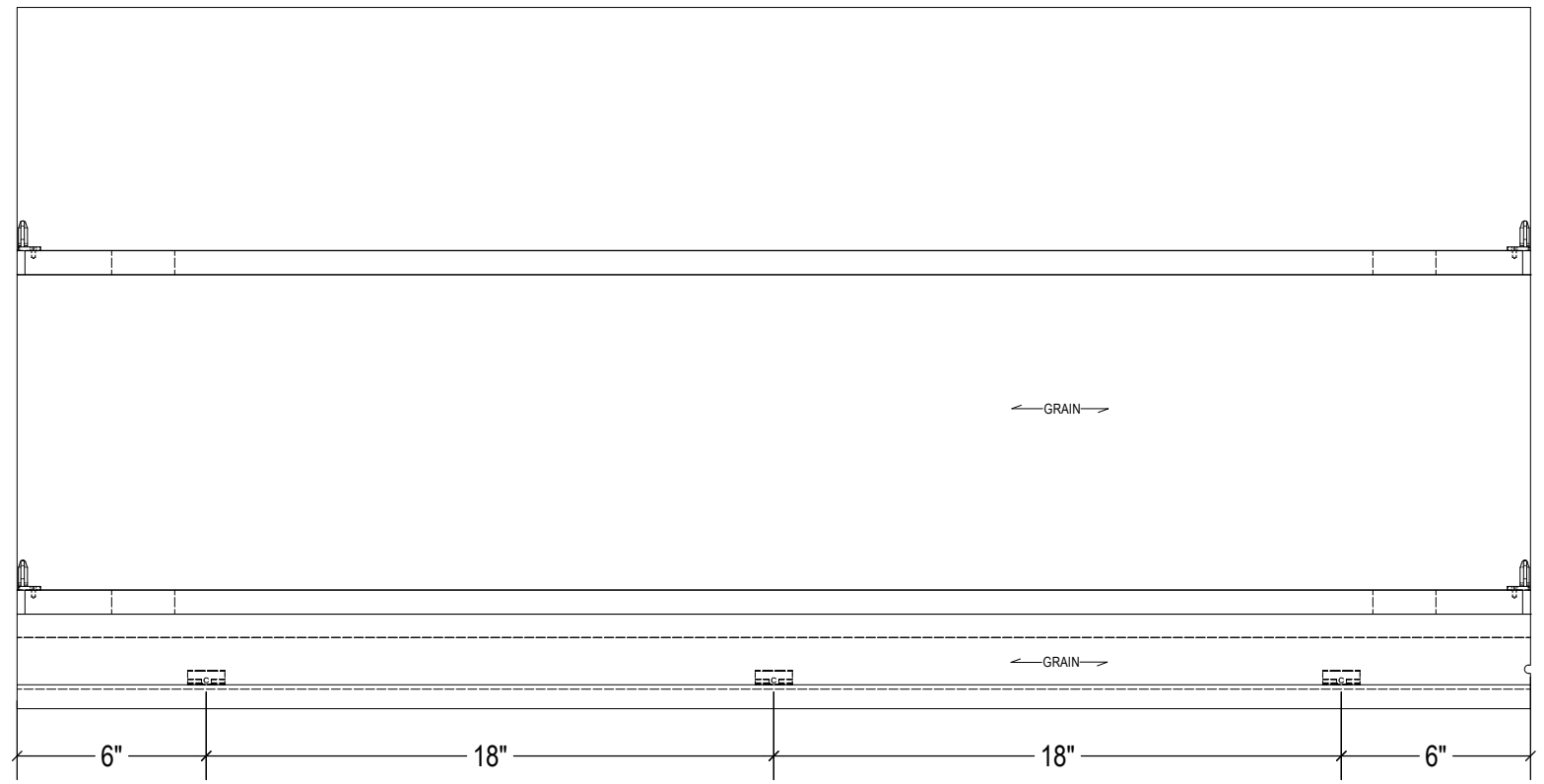

TOP
SCALE 1/6

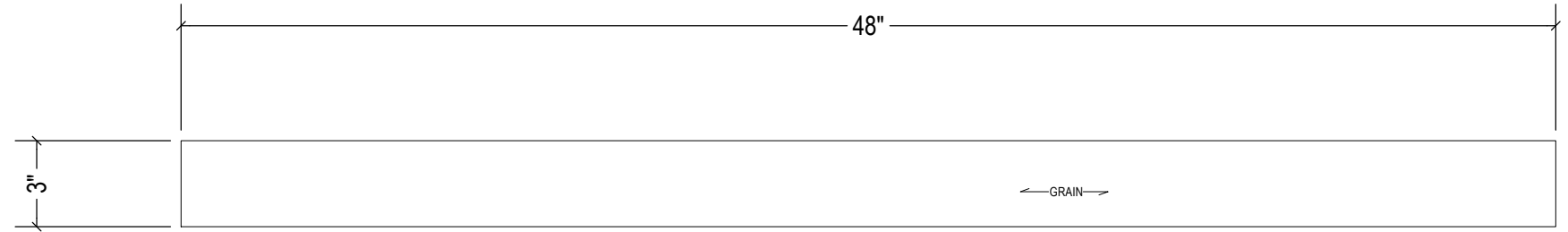

FRONT
SCALE 1/6

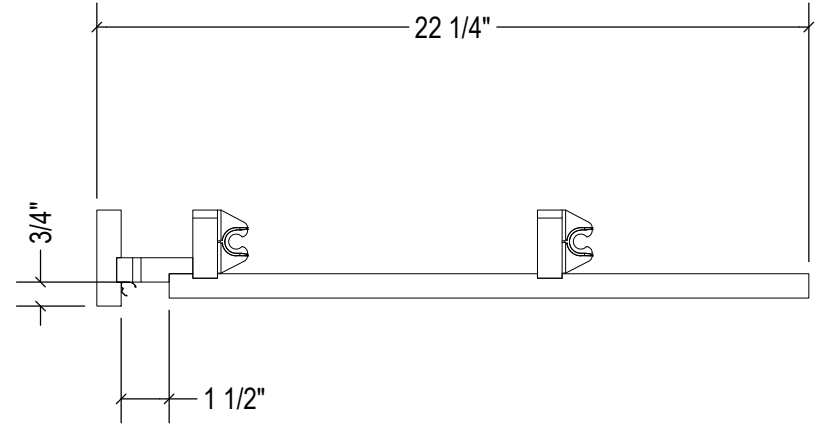

SIDE
SCALE 1/6

FINISH SCHEDULE	
WD-4	PLYBOO VENEER - CARMELIZED FLAT CUT - 20% SHEEN CLEAR
WD-5	PLYBOO - CARMELIZED FLAT CUT - 20% SHEEN CLEAR
WC-2	PHILLIP JEFFRIES ISLAND - 7867 CAPRI NATURAL
LAM-1	HARD ROCK MAPLE
LT-1	STRIP LIGHTS 3000K

PARTS LIST										
ITEM	QTY	PART NUMBER	C.C.	DESCRIPTION	Length	Width	Thk.	Material	Finish	EB
1	2	3083-003A-K-001	FC	STIFFENER	60	2.125	0.765	Medium Density Fiberboard		N/A
2	1	3083-003A-K-01	FC	FRONT	60	3	0.765	PLYBOO G2S	20% SHEEN CLEAR	1L
3	1	3083-003A-K-02	FC	DECK	60	19.985	0.765	PLYBOO G2S	20% SHEEN CLEAR	1L
4	1	3083-003A-K-03	FC	LED PANEL	60	2.375	0.765	PLYBOO G2S	20% SHEEN CLEAR	N/A
5	4	BUTTON_FIX-CLIP-01	P	BUTTON FIX - CLIP						
6	5	SELF-MC45-AR01	P	SELF-MC45-AR	1.181	0.45	0.429	Steel Profile		N/A

DATE:	3/9/2026
DRAWN BY:	BH
FIXTURE NAME:	BB-01
PART #:	3083-003A-K
JOB #:	3083
SHEET #:	003.18
NAPLES BEACH BOUTIQUE NAPLES, FL	
TOP SHELF - 60 INCH	



3939 WASHINGTON BOULEVARD BALTIMORE, MARYLAND 21227-4165
 PH: (410) 242-0400 FX: (410) 242-0475
 A DIVISION OF WEITZMAN INDUSTRIES, INC.

- REVISIONS -

BY	DATE	REMARKS

THIS DRAWING REMAINS THE PROPERTY OF DISPLAY CRAFT MFG CO. THE INFORMATION CONTAINED HEREON IS FOR THE SPECIFIC USE OF THE INDIVIDUAL PROJECT, AND MAY NOT BE USED FOR ANY OTHER PURPOSE WITHOUT THE WRITTEN CONSENT OF DISPLAY CRAFT MFG. CO.

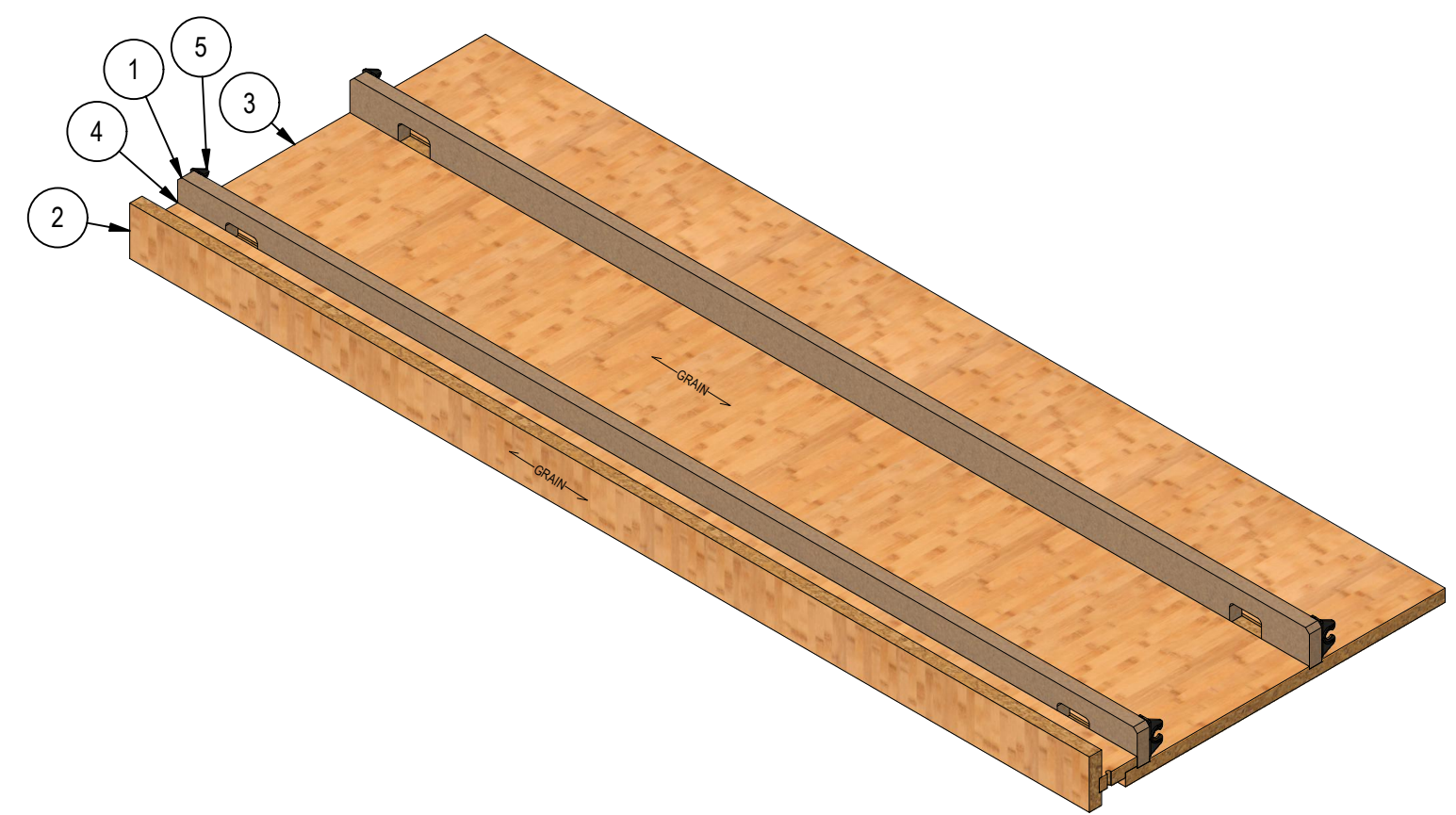
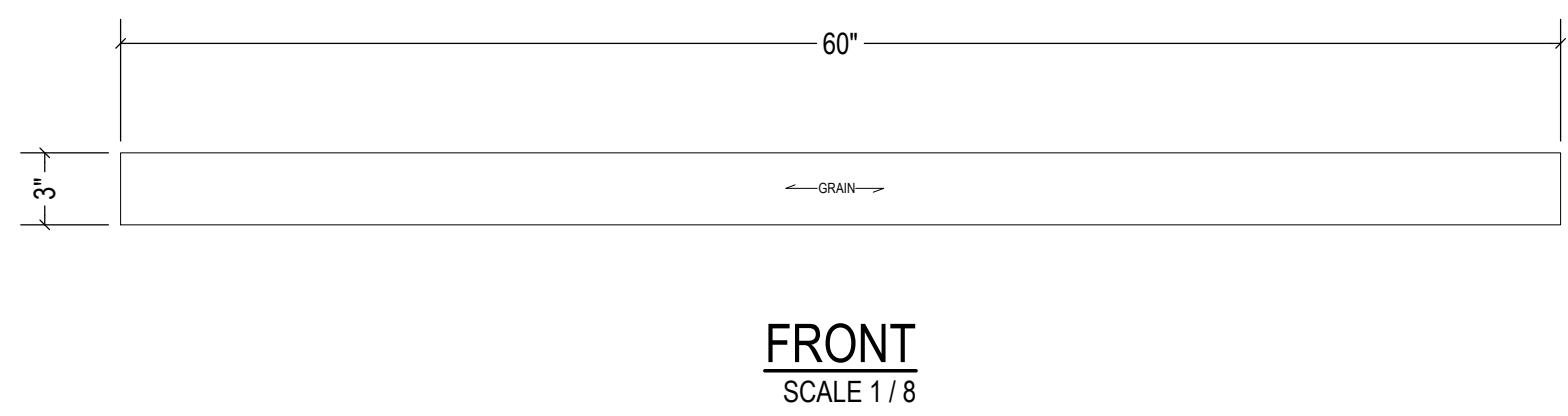
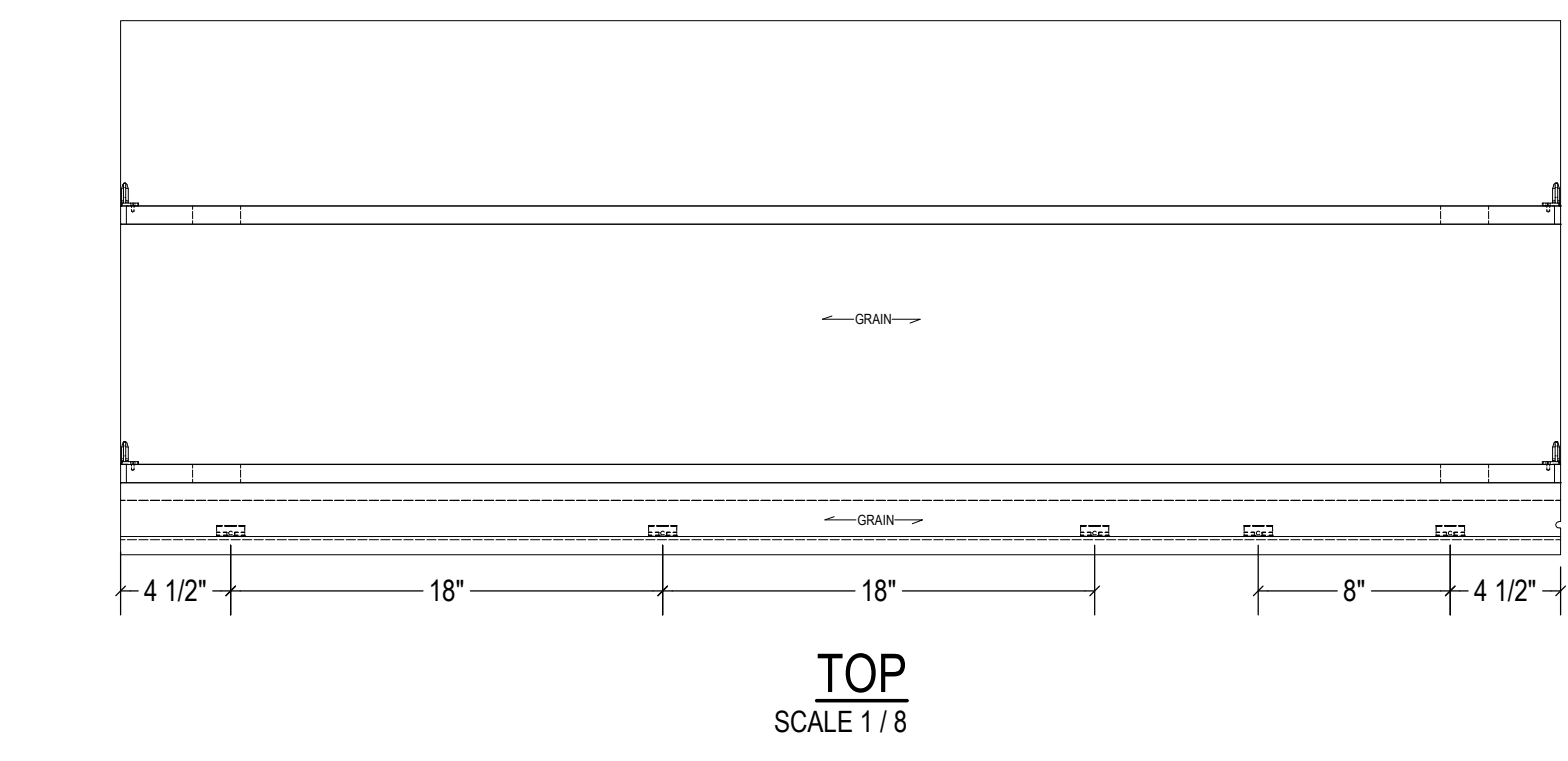

ISO
SCALE 1/8

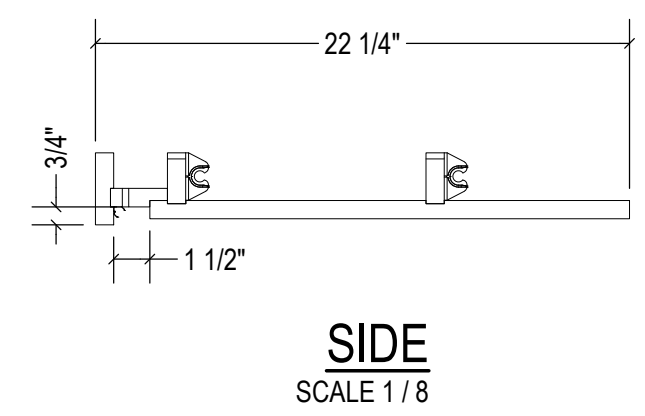

FINISH SCHEDULE	
WD-4	PLYBOO VENEER - CARMELIZED FLAT CUT - 20% SHEEN CLEAR
WD-5	PLYBOO - CARMELIZED FLAT CUT - 20% SHEEN CLEAR
WC-2	PHILLIP JEFFRIES ISLAND - 7867 CAPRI NATURAL
LAM-1	HARD ROCK MAPLE
LT-1	STRIP LIGHTS 3000K

PARTS LIST										
ITEM	QTY	PART NUMBER	C.C.	DESCRIPTION	Length	Width	Thk.	Material	Finish	EB
1	2	3083-003A-L-003	FC	CLIP SPACER	26.125	1.485	0.76	Medium Density Fiberboard		N/A
2	1	3083-003A-L-02	FC	RIGHT STILE	26.125	1.5	0.765	PLYBOO G2S	20% SHEEN CLEAR	N/A
3	1	3083-003A-L-03	FC	LEFT STILE	26.125	1.5	0.765	PLYBOO G2S	20% SHEEN CLEAR	N/A
4	12	3083-003A-L-01	FM	SLAT	44.375	2.131	0.256	PLYBOO G2S	20% SHEEN CLEAR	N/A
5	2	3083-003A-L-001	FS	STILE RISER	26.125	1.625	0.76	Medium Density Fiberboard		N/A
6	2	3083-003A-L-002	FS	RAIL RISER	43.375	1.625	0.76	Medium Density Fiberboard		N/A
7	2	3083-003A-L-04	FS	RAIL	43.375	1.5	0.765	PLYBOO G2S	20% SHEEN CLEAR	N/A
8	2	3083-003A-L-V01	FS	STILE VENEER	26.125	2.25	0.023	PLYBOO G2S	20% SHEEN CLEAR	N/A
9	2	3083-003A-L-V02	FS	RAIL VENEER	43.375	2.25	0.023	PLYBOO G2S	20% SHEEN CLEAR	N/A
10	4	BUTTON_FIX-CLIP-01	P	BUTTON FIX - CLIP						

DATE:	3/9/2026
DRAWN BY:	BH
FIXTURE NAME:	BB-01
PART #:	3083-003A-L
JOB #:	3083
SHEET #:	003.19

NAPLES BEACH BOUTIQUE
NAPLES, FL

LOUVER ASSEMBLY - 48 INCH

Description:

Display Craft
MANUFACTURING CO.

3959 WASHINGTON BOULEVARD BALTIMORE, MARYLAND 21227-4165
PH: (410) 242-0400 FX: (410) 242-0475
A DIVISION OF WEITZMAN INDUSTRIES, INC.

- REVISIONS -	
BY	REMARKS

THIS DRAWING REMAINS THE PROPERTY OF DISPLAY CRAFT MFG CO. THE INFORMATION CONTAINED HEREON IS FOR THE SPECIFIC USE OF THE INDIVIDUAL PROJECT, AND MAY NOT BE USED FOR ANY OTHER PURPOSE WITHOUT THE WRITTEN CONSENT OF DISPLAY CRAFT MFG. CO.

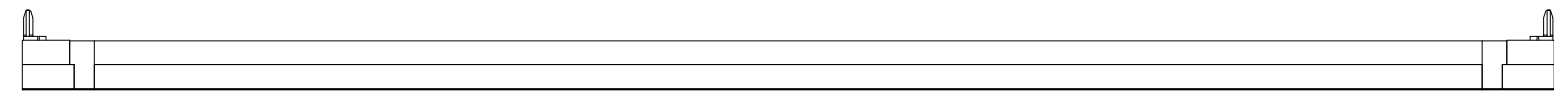

TOP
SCALE 1/6

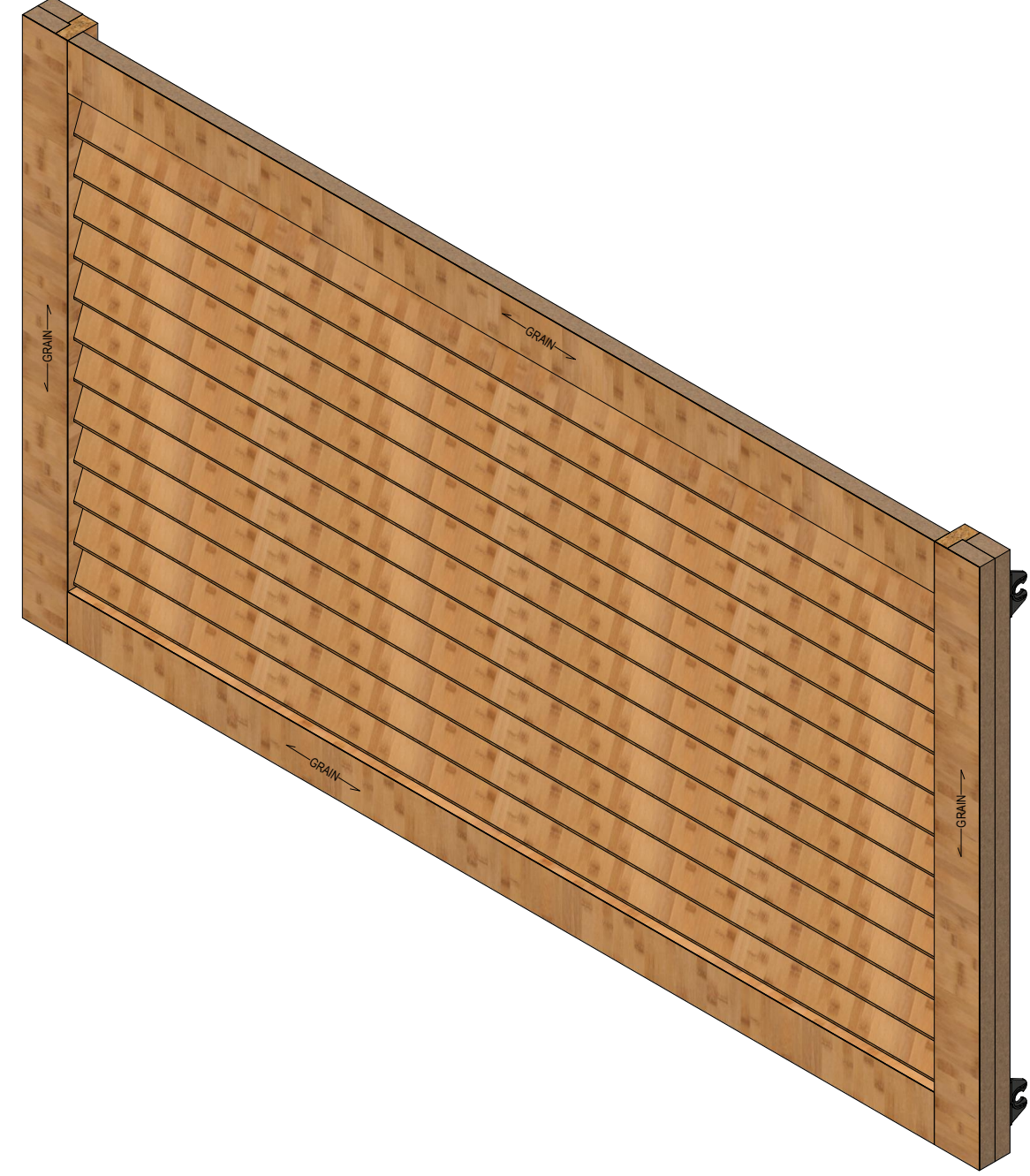

ISO
SCALE 1/6

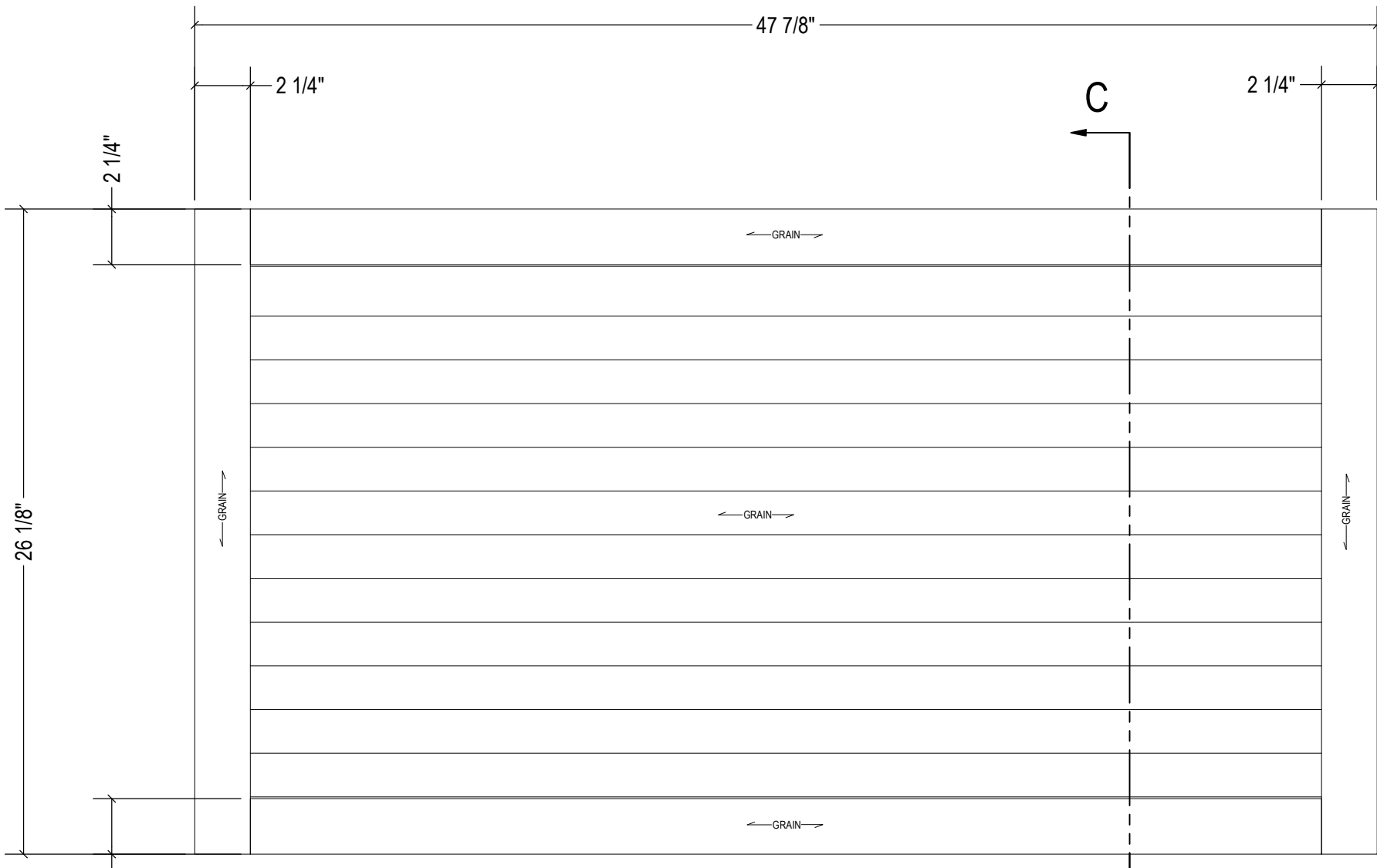

FRONT
SCALE 1/6

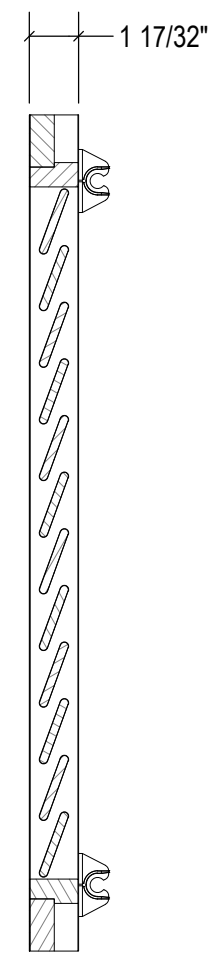

SECTION C
SCALE 1/6

FINISH SCHEDULE	
WD-4	PLYBOO VENEER - CARMELIZED FLAT CUT - 20% SHEEN CLEAR
WD-5	PLYBOO - CARMELIZED FLAT CUT - 20% SHEEN CLEAR
WC-2	PHILLIP JEFFRIES ISLAND - 7867 CAPRI NATURAL
LAM-1	HARD ROCK MAPLE
LT-1	STRIP LIGHTS 3000K

ITEM	QTY	PART NUMBER	C.C.	DESCRIPTION	PARTS LIST			Material	Finish	EB
					Length	Width	Thk.			
1	2	3083-003A-L-003	FC	CLIP SPACER	26.125	1.485	0.76	Medium Density Fiberboard		N/A
2	1	3083-003A-L-02	FC	RIGHT STILE	26.125	1.5	0.765	PLYBOO G2S	20% SHEEN CLEAR	N/A
3	1	3083-003A-L-03	FC	LEFT STILE	26.125	1.5	0.765	PLYBOO G2S	20% SHEEN CLEAR	N/A
4	12	3083-003A-L-01	FM	SLAT	44.375	2.131	0.256	PLYBOO G2S	20% SHEEN CLEAR	N/A
5	2	3083-003A-L-001	FS	STILE RISER	26.125	1.625	0.76	Medium Density Fiberboard		N/A
6	2	3083-003A-L-002	FS	RAIL RISER	43.375	1.625	0.76	Medium Density Fiberboard		N/A
7	2	3083-003A-L-04	FS	RAIL	43.375	1.5	0.765	PLYBOO G2S	20% SHEEN CLEAR	N/A
8	2	3083-003A-L-V01	FS	STILE VENEER	26.125	2.25	0.023	PLYBOO G2S	20% SHEEN CLEAR	N/A
9	2	3083-003A-L-V02	FS	RAIL VENEER	43.375	2.25	0.023	PLYBOO G2S	20% SHEEN CLEAR	N/A
10	4	BUTTON_FIX-CLIP-01	P	BUTTON FIX - CLIP						

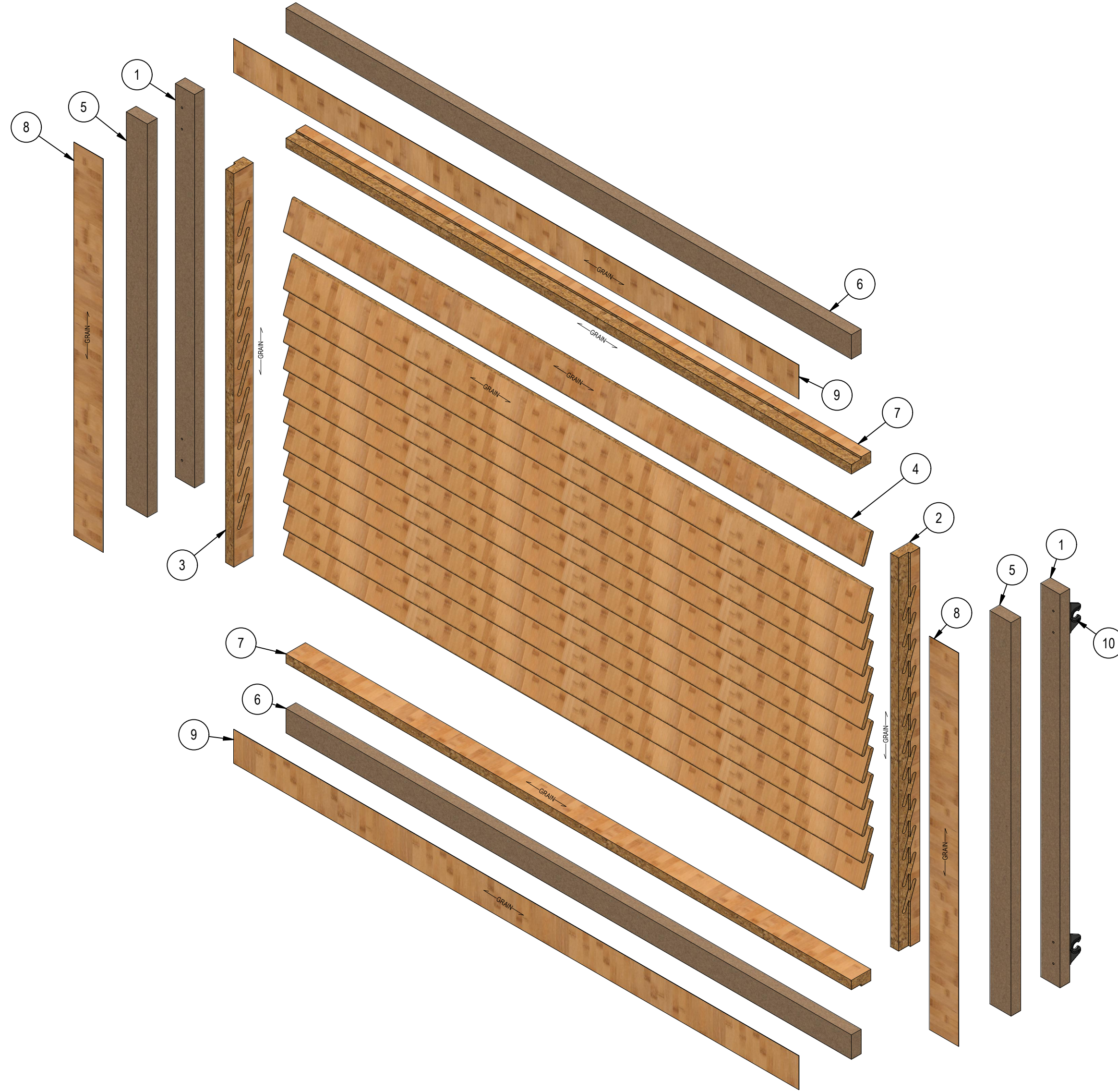

EXPLODED
SCALE 1/5

NAPLES BEACH BOUTIQUE
NAPLES, FL

LOUVER ASSEMBLY - 48 INCH



3939 WASHINGTON BOULEVARD BALTIMORE, MARYLAND 21227-4165
PH: (410) 242-0400 FX: (410) 242-0475
A DIVISION OF WEITZMAN INDUSTRIES, INC.

- REVISIONS -

BY	DATE	REMARKS

THIS DRAWING REMAINS THE PROPERTY OF DISPLAY CRAFT MFG. CO. THE INFORMATION CONTAINED HEREON IS FOR THE SPECIFIC USE OF THE INDIVIDUAL PROJECT, AND MAY NOT BE USED FOR ANY OTHER PURPOSE WITHOUT THE WRITTEN CONSENT OF DISPLAY CRAFT MFG. CO.

DATE: 3/9/2026
DRAWN BY: BH
FIXTURE NAME: BB-01
PART #: 3083-003A-L
JOB #: 3083
SHEET #: 003.20

FINISH SCHEDULE	
WD-4	PLYBOO VENEER - CARMELIZED FLAT CUT - 20% SHEEN CLEAR
WD-5	PLYBOO - CARMELIZED FLAT CUT - 20% SHEEN CLEAR
WC-2	PHILLIP JEFFRIES ISLAND - 7867 CAPRI NATURAL
LAM-1	HARD ROCK MAPLE
LT-1	STRIP LIGHTS 3000K

PARTS LIST										
ITEM	QTY	PART NUMBER	C.C.	DESCRIPTION	Length	Width	Thk.	Material	Finish	EB
1	2	3083-003A-M-004	FC	CLIP SPACER	26.125	1.485	0.76	Medium Density Fiberboard		N/A
2	2	3083-003A-M-03	FC	LEFT STILE	26.125	1.5	0.765	PLYBOO G2S	20% SHEEN CLEAR	N/A
3	2	3083-003A-M-04	FC	RIGHT STILE	26.125	1.5	0.765	PLYBOO G2S	20% SHEEN CLEAR	N/A
4	24	3083-003A-M-01	FM	SLAT	26.437	2.131	0.256	PLYBOO G2S	20% SHEEN CLEAR	N/A
5	4	3083-003A-M-001	FS	RAIL	26.125	1.625	0.76	Medium Density Fiberboard		N/A
6	4	3083-003A-M-002	FS	RAIL RISER	25.437	1.625	0.76	Medium Density Fiberboard		N/A
7	1	3083-003A-M-003	FS	JOINT PANEL	26.125	2.97	0.76	Medium Density Fiberboard		N/A
8	4	3083-003A-M-02	FS	RAIL	25.437	1.5	0.765	PLYBOO G2S	20% SHEEN CLEAR	N/A
9	4	3083-003A-M-V01	FS	STILE VENEER	26.125	2.25	0.023	PLYBOO G2S	20% SHEEN CLEAR	N/A
10	4	3083-003A-M-V02	FS	RAIL VENEER	25.437	2.25	0.023	PLYBOO G2S	20% SHEEN CLEAR	N/A
11	4	BUTTON_FIX-CLIP-01	P	BUTTON FIX - CLIP						

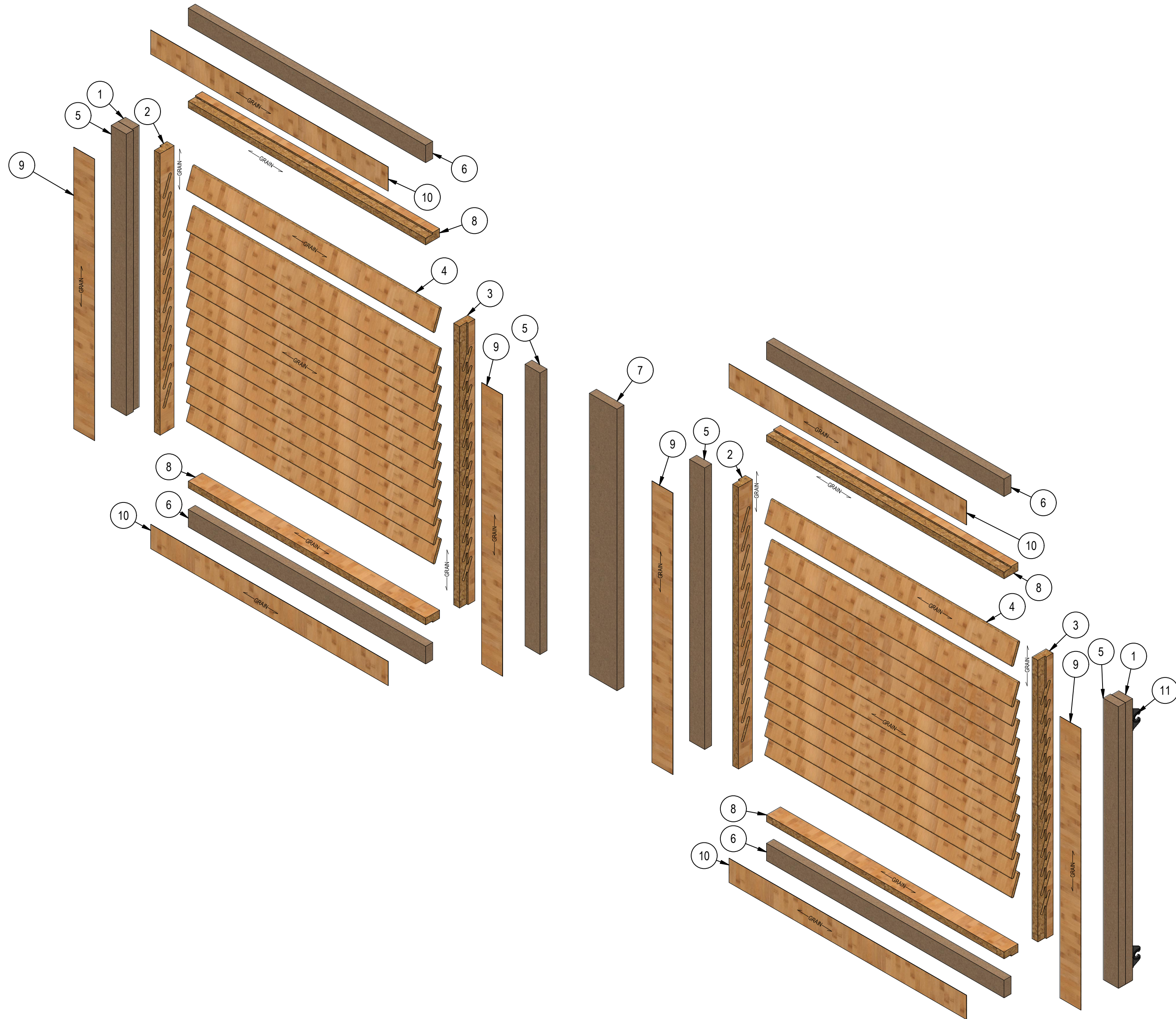

EXPLODED
SCALE 1/6

NAPLES BEACH BOUTIQUE
NAPLES, FL

LOUVER ASSEMBLY - 60 INCH



3939 WASHINGTON BOULEVARD BALTIMORE, MARYLAND 21227-4165
PH: (410) 242-0400 FX: (410) 242-0475
A DIVISION OF WEITZMAN INDUSTRIES, INC.

- REVISIONS -

BY	DATE	REMARKS

THIS DRAWING REMAINS THE PROPERTY OF DISPLAY CRAFT MFG CO. THE INFORMATION CONTAINED HEREON IS FOR THE SPECIFIC USE OF THE INDIVIDUAL PROJECT, AND MAY NOT BE USED FOR ANY OTHER PURPOSE WITHOUT THE WRITTEN CONSENT OF DISPLAY CRAFT MFG. CO.

DATE:	3/9/2026
DRAWN BY:	BH
FIXTURE NAME:	BB-01
PART #:	3083-003A-M
JOB #:	3083
SHEET #:	003.22

FINISH SCHEDULE	
WD-4	PLYBOO VENEER - CARMELIZED FLAT CUT - 20% SHEEN CLEAR
WD-5	PLYBOO - CARMELIZED FLAT CUT - 20% SHEEN CLEAR
WC-2	PHILLIP JEFFRIES ISLAND - 7867 CAPRI NATURAL
LAM-1	HARD ROCK MAPLE
LT-1	STRIP LIGHTS 3000K

ITEM	QTY	PART NUMBER	C.C.	DESCRIPTION	PARTS LIST			Material	Finish	EB
					Length	Width	Thk.			
1	1	3083-003A-R-01	FC	STANDARDS PANEL - 48 IN W/O CAB	84.125	47.969	0.76	Medium Density Fiberboard		N/A
2	2	3083-003A-R-02	FC	STANDARDS PANEL CLEAT - 48 IN	47	5.5	0.76	Medium Density Fiberboard		N/A
3	2	SELF_ELEC-STD-LONG	P	SELF ELECTRIC STANDARD				ALUMINUM		

DATE:	3/9/2026
DRAWN BY:	BH
FIXTURE NAME:	BB-01
PART #:	3083-003A-R
JOB #:	3083
SHEET #:	003.27

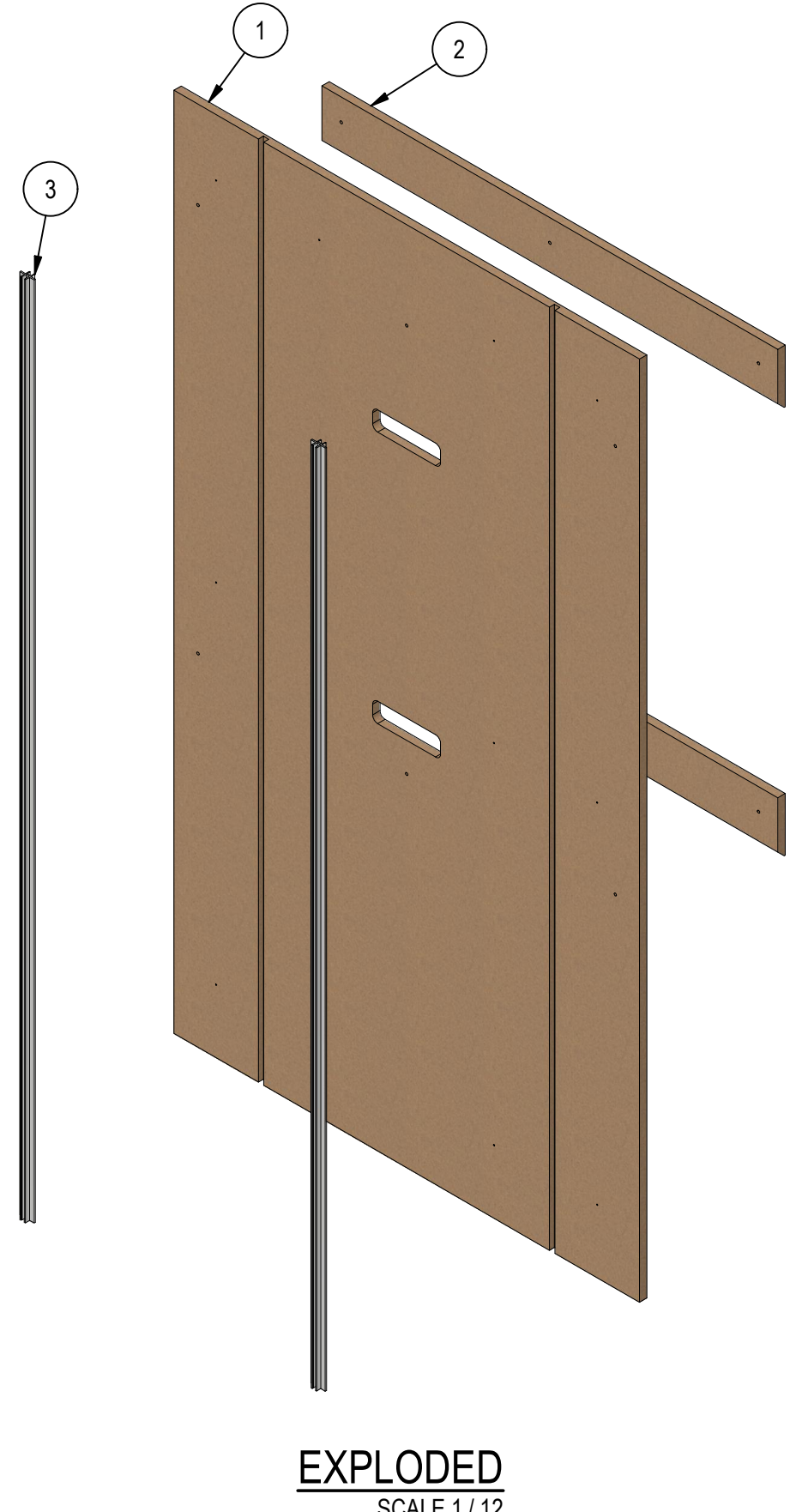
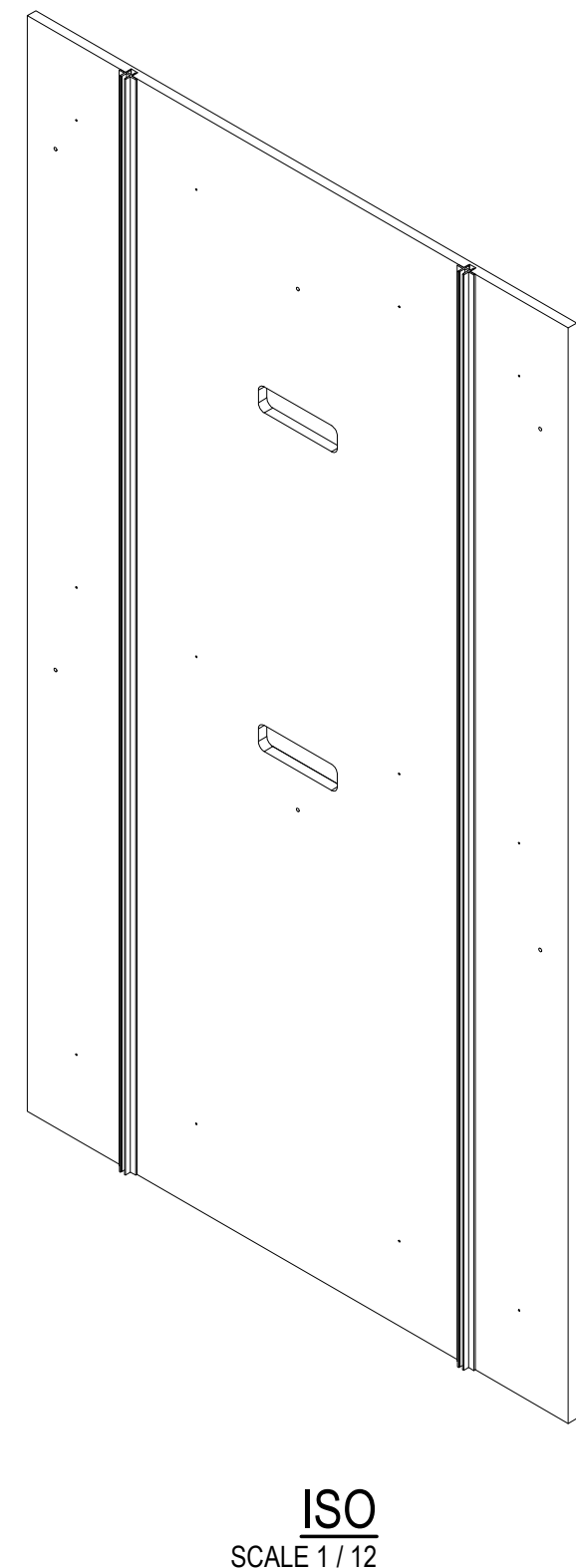
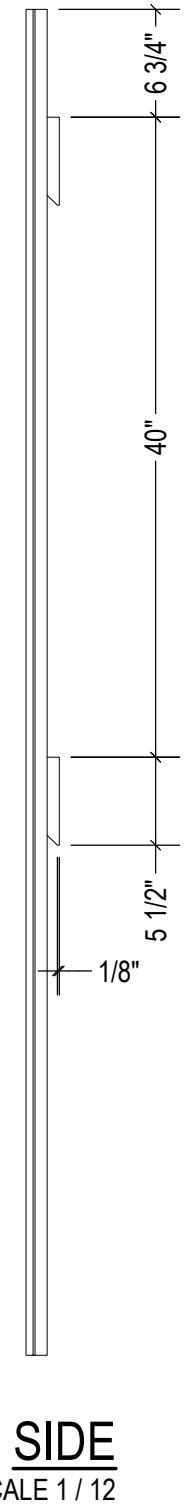
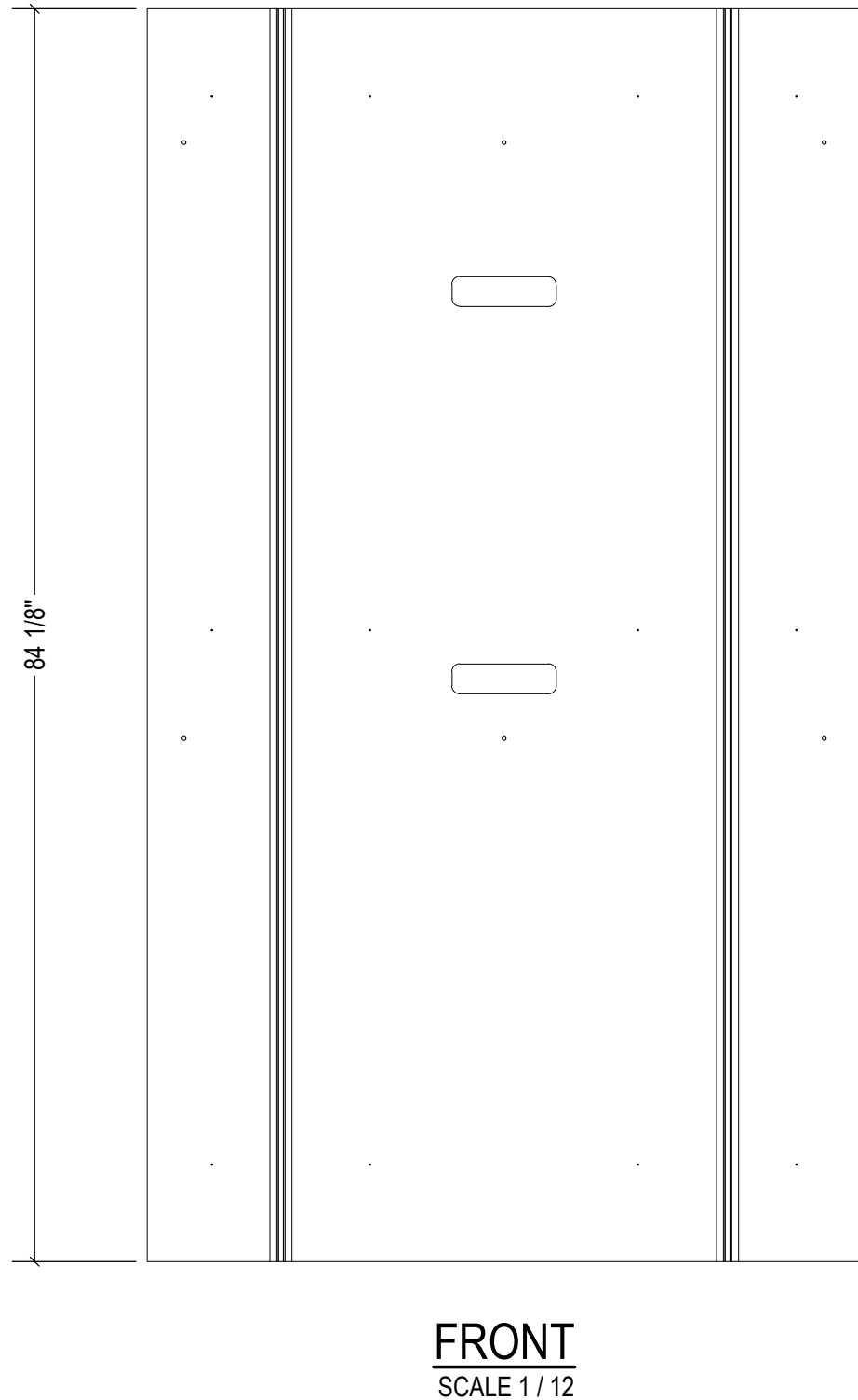
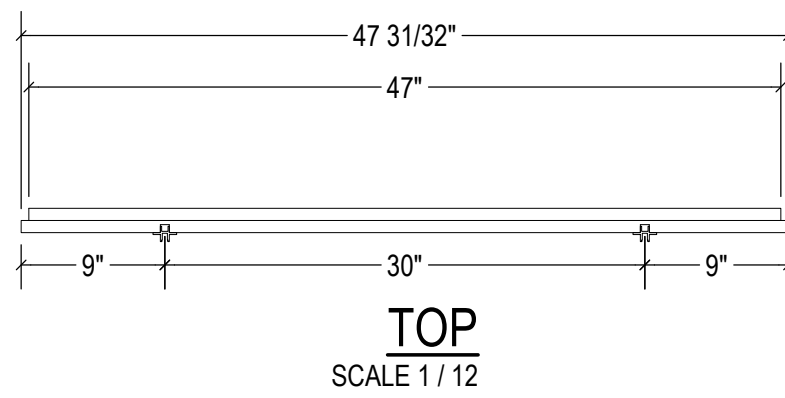

NAPLES BEACH BOUTIQUE
NAPLES, FL



3939 WASHINGTON BOULEVARD BALTIMORE, MARYLAND 21227-4165
PH: (410) 242-0400 FX: (410) 242-0475
A DIVISION OF WEITZMAN INDUSTRIES, INC.

STANDARDS PANEL ASSEM - 48 IN W/O CAB

- REVISIONS -		
BY	DATE	REMARKS

THIS DRAWING REMAINS THE PROPERTY OF DISPLAY CRAFT MFG CO. THE INFORMATION CONTAINED HEREON IS FOR THE SPECIFIC USE OF THE INDIVIDUAL PROJECT, AND MAY NOT BE USED FOR ANY OTHER PURPOSE WITHOUT THE WRITTEN CONSENT OF DISPLAY CRAFT MFG. CO.

FINISH SCHEDULE	
WD-4	PLYBOO VENEER - CARMELIZED FLAT CUT - 20% SHEEN CLEAR
WD-5	PLYBOO - CARMELIZED FLAT CUT - 20% SHEEN CLEAR
WC-2	PHILLIP JEFFRIES ISLAND - 7867 CAPRI NATURAL
LAM-1	HARD ROCK MAPLE
LT-1	STRIP LIGHTS 3000K

ITEM	QTY	PART NUMBER	C.C.	DESCRIPTION	PARTS LIST				Material	Finish	EB
					Length	Width	Thk.				
1	2	3083-003A-R-02	FC	STANDARDS PANEL CLEAT - 48 IN	47	5.5	0.76		Medium Density Fiberboard		N/A
2	1	3083-003A-T-01	FC	STANDARDS PANEL - 48 IN W/ CAB	67.875	47.969	0.76		Medium Density Fiberboard		N/A
3	2	SELF_ELEC-STD	P	STANDARD					ALUMINUM		

DATE:	3/9/2026
DRAWN BY:	BH
FIXTURE NAME:	BB-01
PART #:	3083-003A-T
JOB #:	3083
SHEET #:	003.28

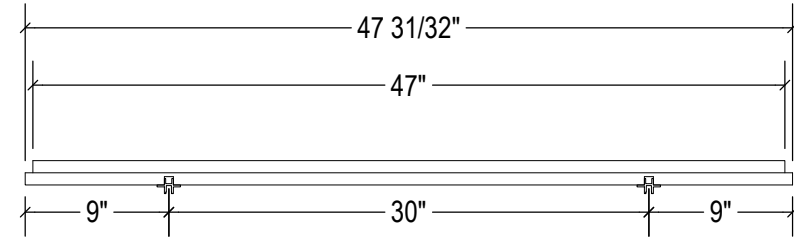

TOP
SCALE 1 / 12

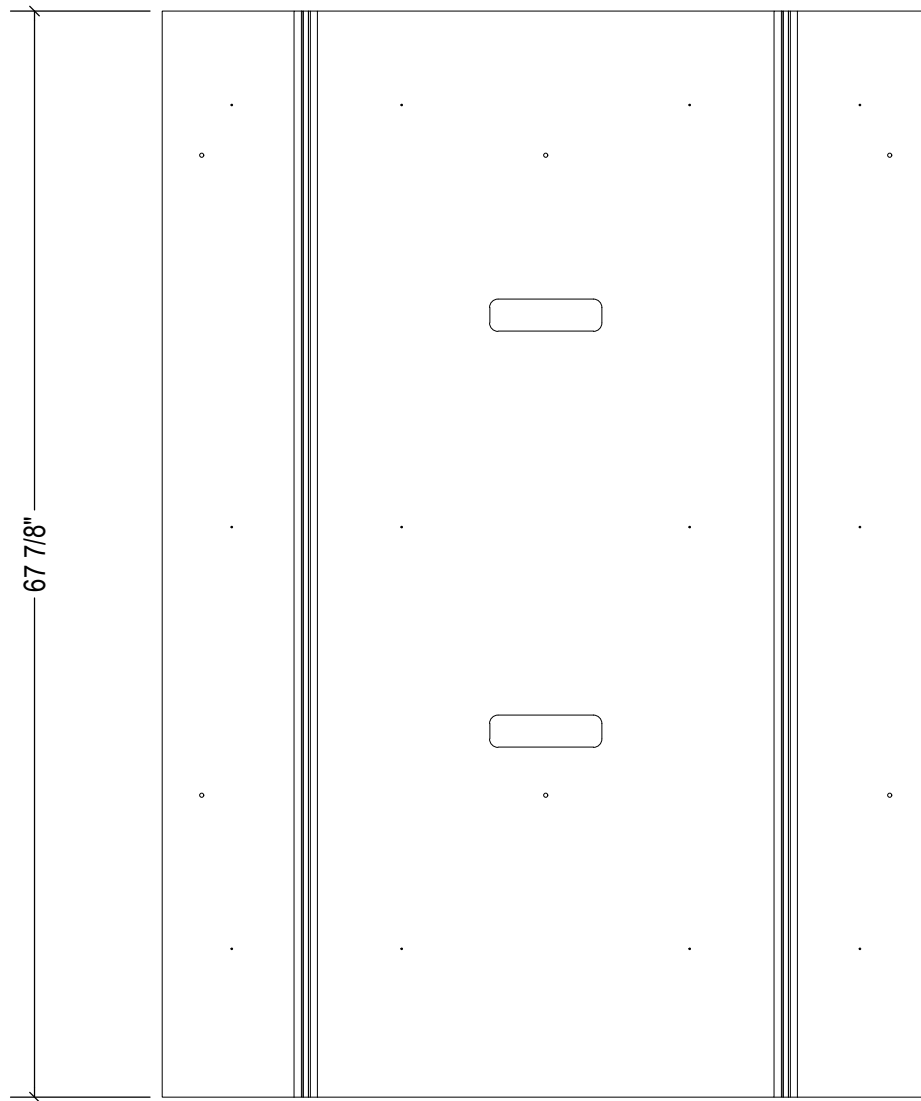

FRONT
SCALE 1 / 12

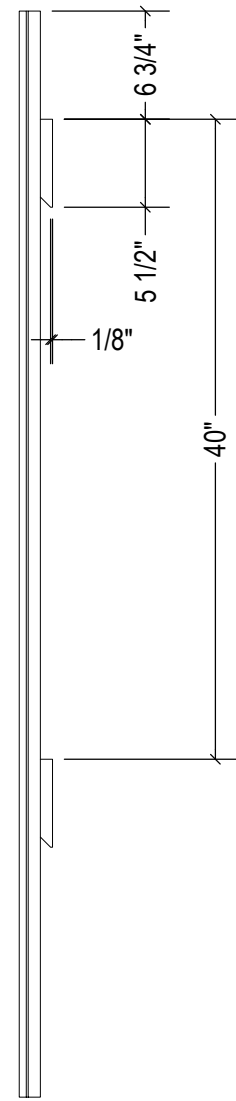

SIDE
SCALE 1 / 12

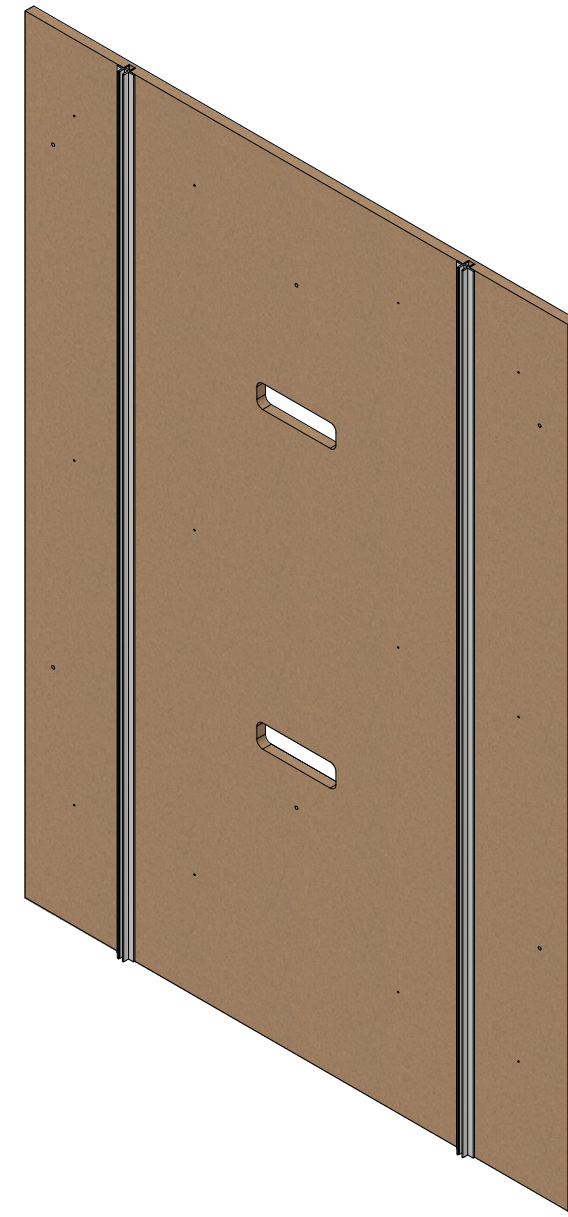

ISO
SCALE 1 / 12

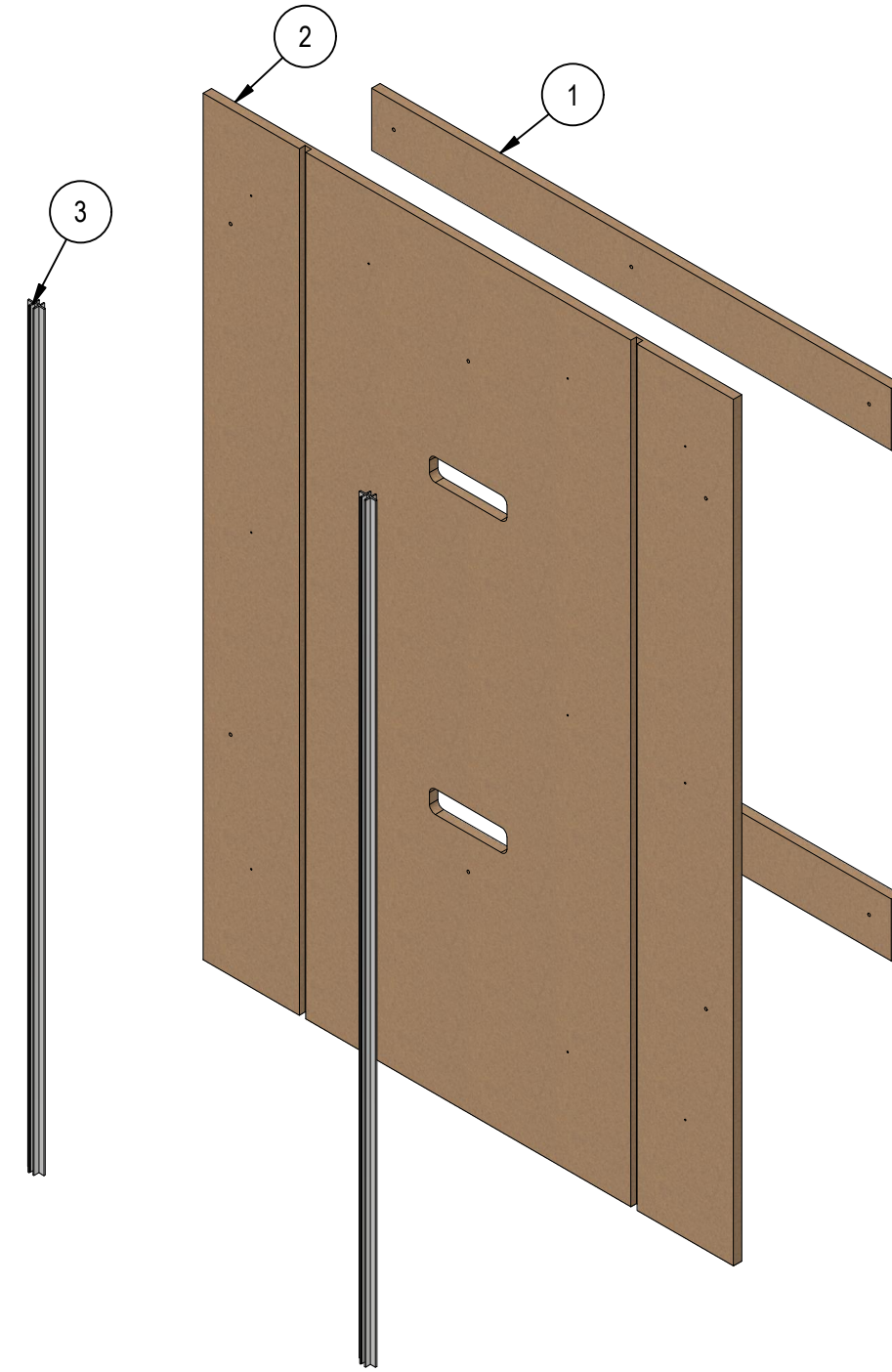

EXPLODED
SCALE 1 / 12

NAPLES BEACH BOUTIQUE
NAPLES, FL

Description:
STANDARDS PANEL ASSEM - 48 IN W/ CAB



3939 WASHINGTON BOULEVARD BALTIMORE, MARYLAND 21227-4165
PH: (410) 242-0400 FX: (410) 242-0475
A DIVISION OF WEITZMAN INDUSTRIES, INC.

- REVISIONS -

BY	DATE	REMARKS

THIS DRAWING REMAINS THE PROPERTY OF DISPLAY CRAFT MFG CO. THE INFORMATION CONTAINED HEREON IS FOR THE SPECIFIC USE OF THE INDIVIDUAL PROJECT, AND MAY NOT BE USED FOR ANY OTHER PURPOSE WITHOUT THE WRITTEN CONSENT OF DISPLAY CRAFT MFG. CO.

FINISH SCHEDULE	
WD-4	PLYBOO VENEER - CARMELIZED FLAT CUT - 20% SHEEN CLEAR
WD-5	PLYBOO - CARMELIZED FLAT CUT - 20% SHEEN CLEAR
WC-2	PHILLIP JEFFRIES ISLAND - 7867 CAPRI NATURAL
LAM-1	HARD ROCK MAPLE
LT-1	STRIP LIGHTS 3000K

ITEM	QTY	PART NUMBER	C.C.	DESCRIPTION	PARTS LIST					
					Length	Width	Thk.	Material	Finish	EB
1	1	3083-003A-U-01	FC	STANDARDS PANEL - 60 IN W/ CAB	67.875	59.969	0.76	Medium Density Fiberboard		N/A
2	2	3083-003A-U-02	FC	STANDARDS PANEL CLEAT - 60 IN	59	5.5	0.76	Medium Density Fiberboard		N/A
3	2	SELF_ELEC-STD	P	STANDARD				ALUMINUM		

DATE:	3/9/2026
DRAWN BY:	BH
FEATURE NAME:	BB-01
PART #:	3083-003A-U
JOB #:	3083
SHEET #:	003.29

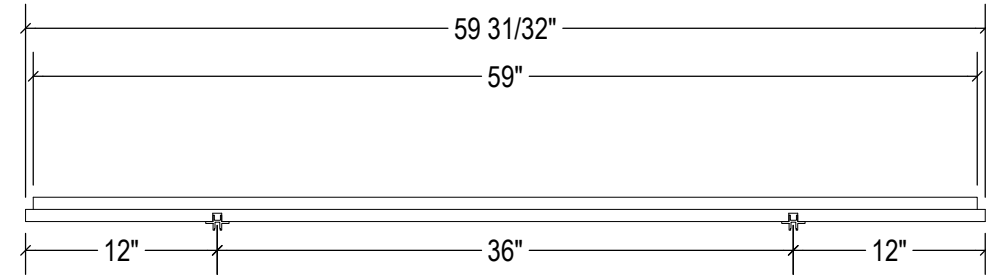

TOP
SCALE 1 / 12



FRONT
SCALE 1 / 12

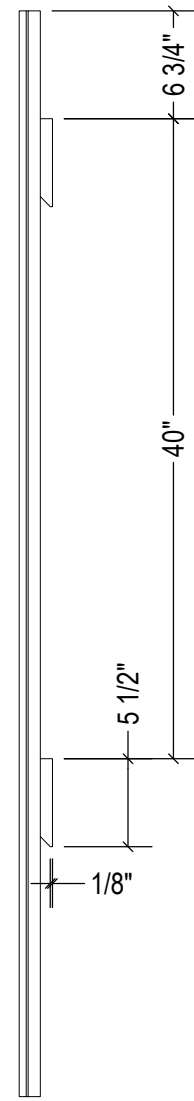

SIDE
SCALE 1 / 12

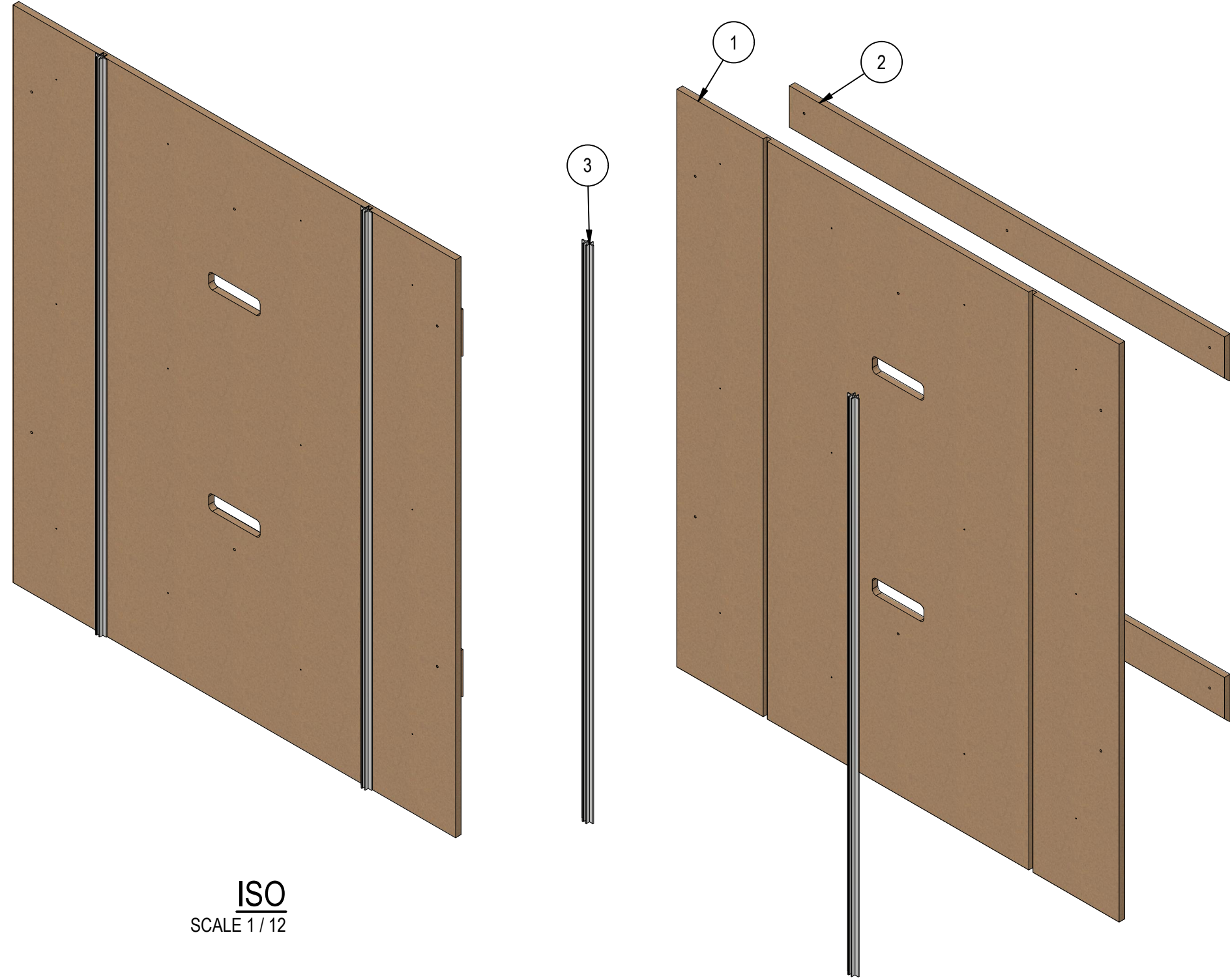

ISO
SCALE 1 / 12

EXPLODED
SCALE 1 / 12

NAPLES BEACH BOUTIQUE
NAPLES, FL



3959 WASHINGTON BOULEVARD BALTIMORE, MARYLAND 21227-4165
PH: (410) 242-0400 FX: (410) 242-0475
A DIVISION OF WEITZMAN INDUSTRIES, INC.

STANDARDS PANEL ASSEM - 60 IN W/ CAB

- REVISIONS -

BY	DATE	REMARKS

THIS DRAWING REMAINS THE PROPERTY OF DISPLAY CRAFT MFG CO. THE INFORMATION CONTAINED HEREON IS FOR THE SPECIFIC USE OF THE INDIVIDUAL PROJECT, AND MAY NOT BE USED FOR ANY OTHER PURPOSE WITHOUT THE WRITTEN CONSENT OF DISPLAY CRAFT MFG. CO.

FINISH SCHEDULE	
WD-4	PLYBOO VENEER - CARMELIZED FLAT CUT - 20% SHEEN CLEAR
WD-5	PLYBOO - CARMELIZED FLAT CUT - 20% SHEEN CLEAR
WC-2	PHILLIP JEFFRIES ISLAND - 7867 CAPRI NATURAL
LAM-1	HARD ROCK MAPLE
LT-1	STRIP LIGHTS 3000K

ITEM	QTY	PART NUMBER	C.C.	DESCRIPTION	PARTS LIST						
					Length	Width	Thk.	Material	Finish	EB	
1	1	3083-003A-VA-01	FC	FINISH PANEL - 48 IN W/O CAB - OUTSIDE	83.625	8.656	0.51	Medium Density Fiberboard	PRIME ALL FACES	N/A	
2	3	STAR_HANGER_227-01	P	227 - 10 lbs HOLD						N/A	

DATE:	3/9/2026
DRAWN BY:	BH
FIXTURE NAME:	BB-01
PART #:	3083-003A-VA
JOB #:	3083
SHEET #:	003.30

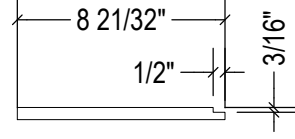

TOP
SCALE 1/8

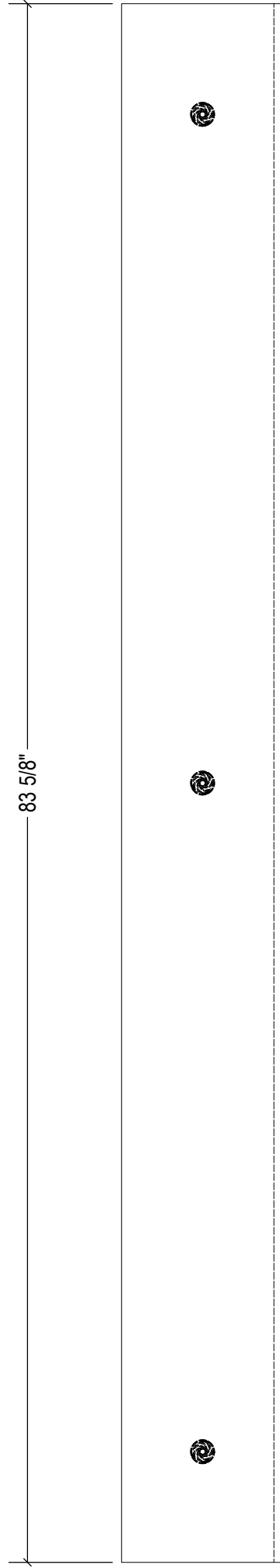

FRONT
SCALE 1/8



SIDE
SCALE 1/8

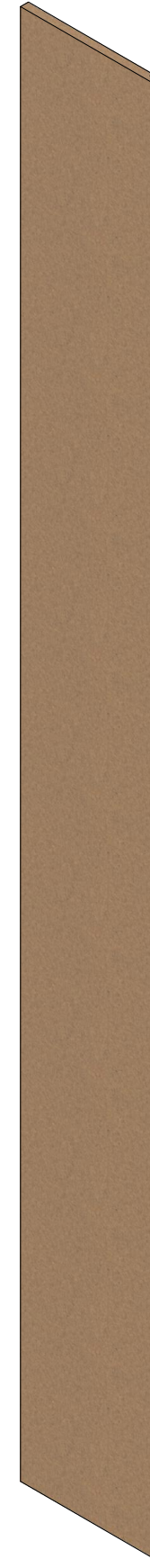

ISO
SCALE 1/8

NAPLES BEACH BOUTIQUE
NAPLES, FL

Description:
FINISH PANEL ASSEMBLY - 48 IN W/O CAB



3939 WASHINGTON BOULEVARD BALTIMORE, MARYLAND 21227-4165
PH: (410) 242-0400 FX: (410) 242-0475
A DIVISION OF WEITZMAN INDUSTRIES, INC.

- REVISIONS -		
BY	DATE	REMARKS

THIS DRAWING REMAINS THE PROPERTY OF DISPLAY CRAFT MFG CO. THE INFORMATION CONTAINED HEREON IS FOR THE SPECIFIC USE OF THE INDIVIDUAL PROJECT, AND MAY NOT BE USED FOR ANY OTHER PURPOSE WITHOUT THE WRITTEN CONSENT OF DISPLAY CRAFT MFG. CO.

FINISH SCHEDULE	
WD-4	PLYBOO VENEER - CARMELIZED FLAT CUT - 20% SHEEN CLEAR
WD-5	PLYBOO - CARMELIZED FLAT CUT - 20% SHEEN CLEAR
WC-2	PHILLIP JEFFRIES ISLAND - 7867 CAPRI NATURAL
LAM-1	HARD ROCK MAPLE
LT-1	STRIP LIGHTS 3000K

ITEM	QTY	PART NUMBER	C.C.	DESCRIPTION	PARTS LIST			Material	Finish	EB
					Length	Width	Thk.			
1	1	3083-003A-VC-01	FC	FINISH PANEL - 60 IN W/ CAB - OUTSIDE	64.625	11.656	0.51	Medium Density Fiberboard	PRIME ALL FACES	N/A
2	3	STAR_HANGER_227-01	P	227 - 10 lbs HOLD						N/A

DATE:	3/9/2026
DRAWN BY:	BH
FIXTURE NAME:	BB-01
PART #:	3083-003A-VC
JOB #:	3083
SHEET #:	003.32

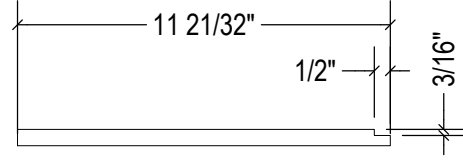

TOP
SCALE 1/6

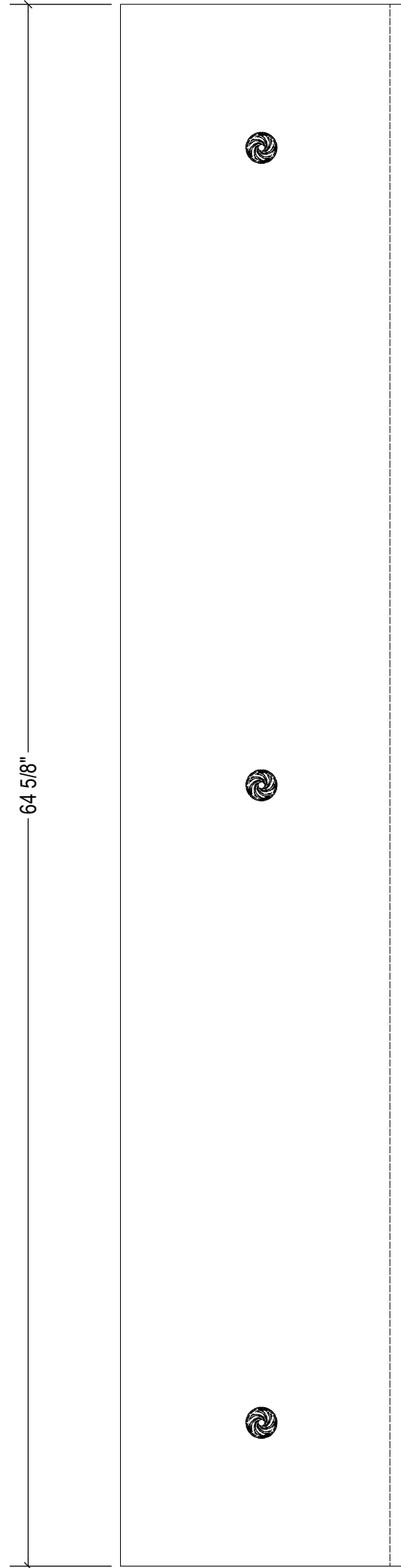

FRONT
SCALE 1/6



SIDE
SCALE 1/6



ISO
SCALE 1/6

NAPLES BEACH BOUTIQUE
NAPLES, FL

Description:
FINISH PANEL ASSEMBLY - 60 IN W/ CAB



3939 WASHINGTON BOULEVARD BALTIMORE, MARYLAND 21227-4165
PH: (410) 242-0400 FX: (410) 242-0475
A DIVISION OF WEITZMAN INDUSTRIES, INC.

- REVISIONS -

BY	DATE	REMARKS

THIS DRAWING REMAINS THE PROPERTY OF DISPLAY CRAFT MFG CO. THE INFORMATION CONTAINED HEREON IS FOR THE SPECIFIC USE OF THE INDIVIDUAL PROJECT, AND MAY NOT BE USED FOR ANY OTHER PURPOSE WITHOUT THE WRITTEN CONSENT OF DISPLAY CRAFT MFG. CO.

FINISH SCHEDULE	
WD-4	PLYBOO VENEER - CARMELIZED FLAT CUT - 20% SHEEN CLEAR
WD-5	PLYBOO - CARMELIZED FLAT CUT - 20% SHEEN CLEAR
WC-2	PHILLIP JEFFRIES ISLAND - 7867 CAPRI NATURAL
LAM-1	HARD ROCK MAPLE
LT-1	STRIP LIGHTS 3000K

ITEM	QTY	PART NUMBER	C.C.	DESCRIPTION	PARTS LIST						
					Length	Width	Thk.	Material	Finish	EB	
1	1	3083-003A-WA01	FC	FINISH PANEL - 48 IN W/O CAB - CENTER	83.625	29.375	0.51	Medium Density Fiberboard	PRIME ALL FACES	N/A	
2	6	STAR_HANGER_227-01	P	227 - 10 lbs HOLD						N/A	

DATE:	3/9/2026
DRAWN BY:	BH
FIXTURE NAME:	BB-01
PART #:	3083-003A-WA
JOB #:	3083
SHEET #:	003.33

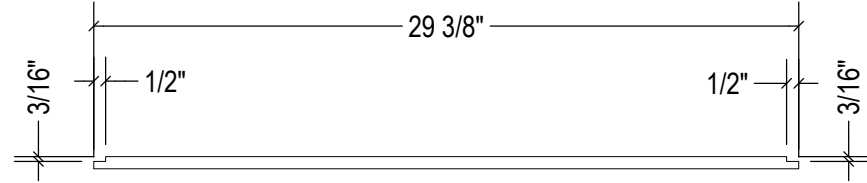

TOP
SCALE 1/8

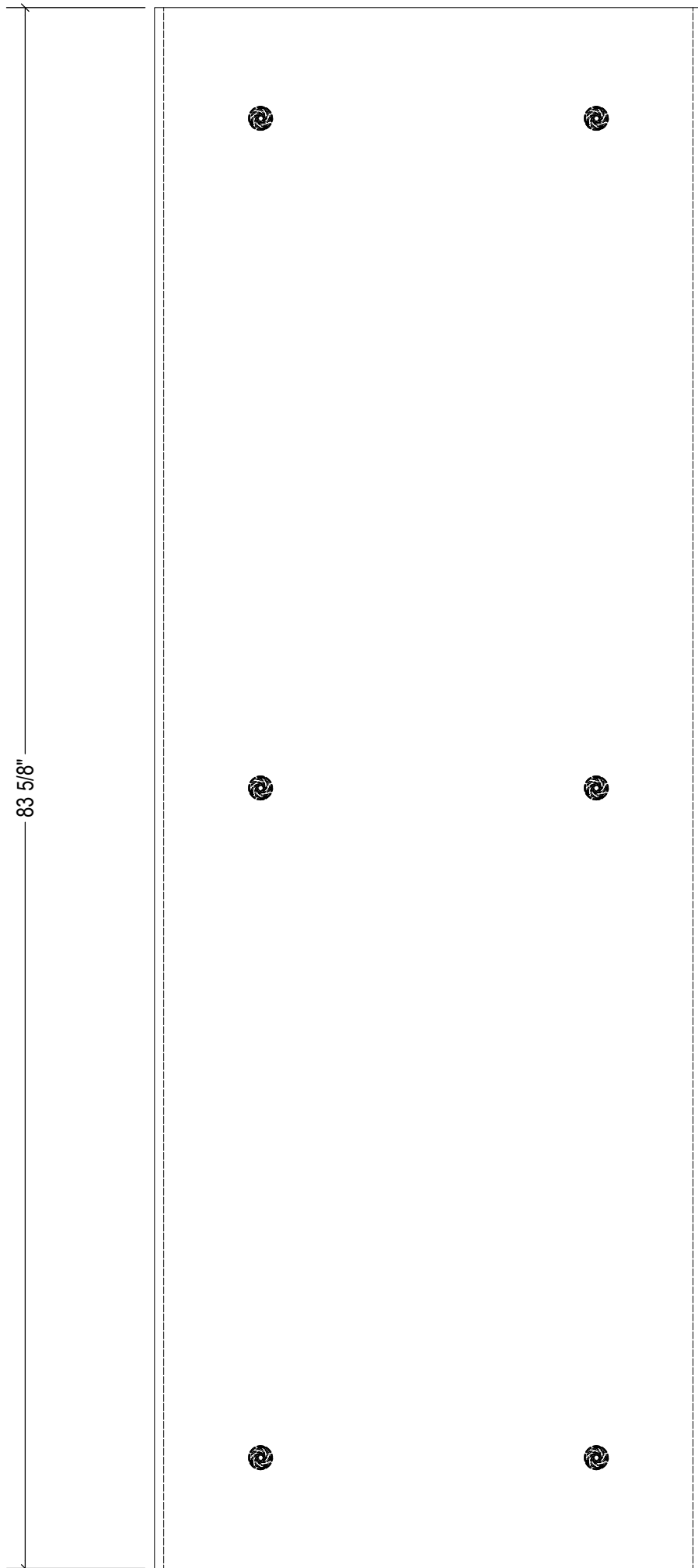

FRONT
SCALE 1/8



SIDE
SCALE 1/8

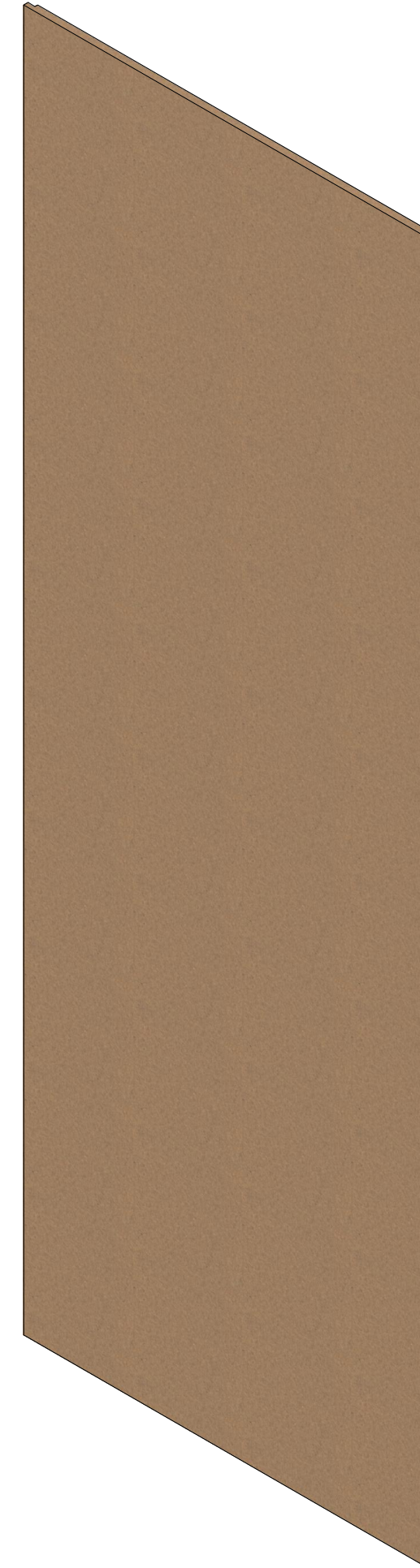

ISO
SCALE 1/8

NAPLES BEACH BOUTIQUE
NAPLES, FL

Description:
FINISH PNL ASM - 48 IN W/O CAB - CENTER



3939 WASHINGTON BOULEVARD BALTIMORE, MARYLAND 21227-4165
PH: (410) 242-0400 FX: (410) 242-0475
A DIVISION OF WEITZMAN INDUSTRIES, INC.

- REVISIONS -	
BY	DATE

THIS DRAWING REMAINS THE PROPERTY OF DISPLAY CRAFT MFG CO. THE INFORMATION CONTAINED HEREON IS FOR THE SPECIFIC USE OF THE INDIVIDUAL PROJECT, AND MAY NOT BE USED FOR ANY OTHER PURPOSE WITHOUT THE WRITTEN CONSENT OF DISPLAY CRAFT MFG. CO.

FINISH SCHEDULE	
WD-4	PLYBOO VENEER - CARMELIZED FLAT CUT - 20% SHEEN CLEAR
WD-5	PLYBOO - CARMELIZED FLAT CUT - 20% SHEEN CLEAR
WC-2	PHILLIP JEFFRIES ISLAND - 7867 CAPRI NATURAL
LAM-1	HARD ROCK MAPLE
LT-1	STRIP LIGHTS 3000K

ITEM	QTY	PART NUMBER	C.C.	DESCRIPTION	PARTS LIST			Material	Finish	EB
					Length	Width	Thk.			
1	1	3083-003A-WB-01	FC	FINISH PANEL - 48 IN W/ CAB - CENTER	64.687	29.375	0.51	Medium Density Fiberboard	PRIMER ALL FACES	N/A
2	6	STAR_HANGER_227-01	P	227 - 10 lbs HOLD						N/A

DATE:	3/9/2026
DRAWN BY:	BH
FIXTURE NAME:	BB-01
PART #:	3083-003A-WB
JOB #:	3083
SHEET #:	003.34

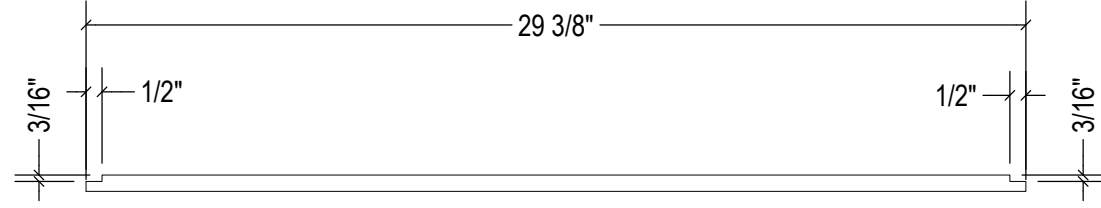

TOP
SCALE 1/6

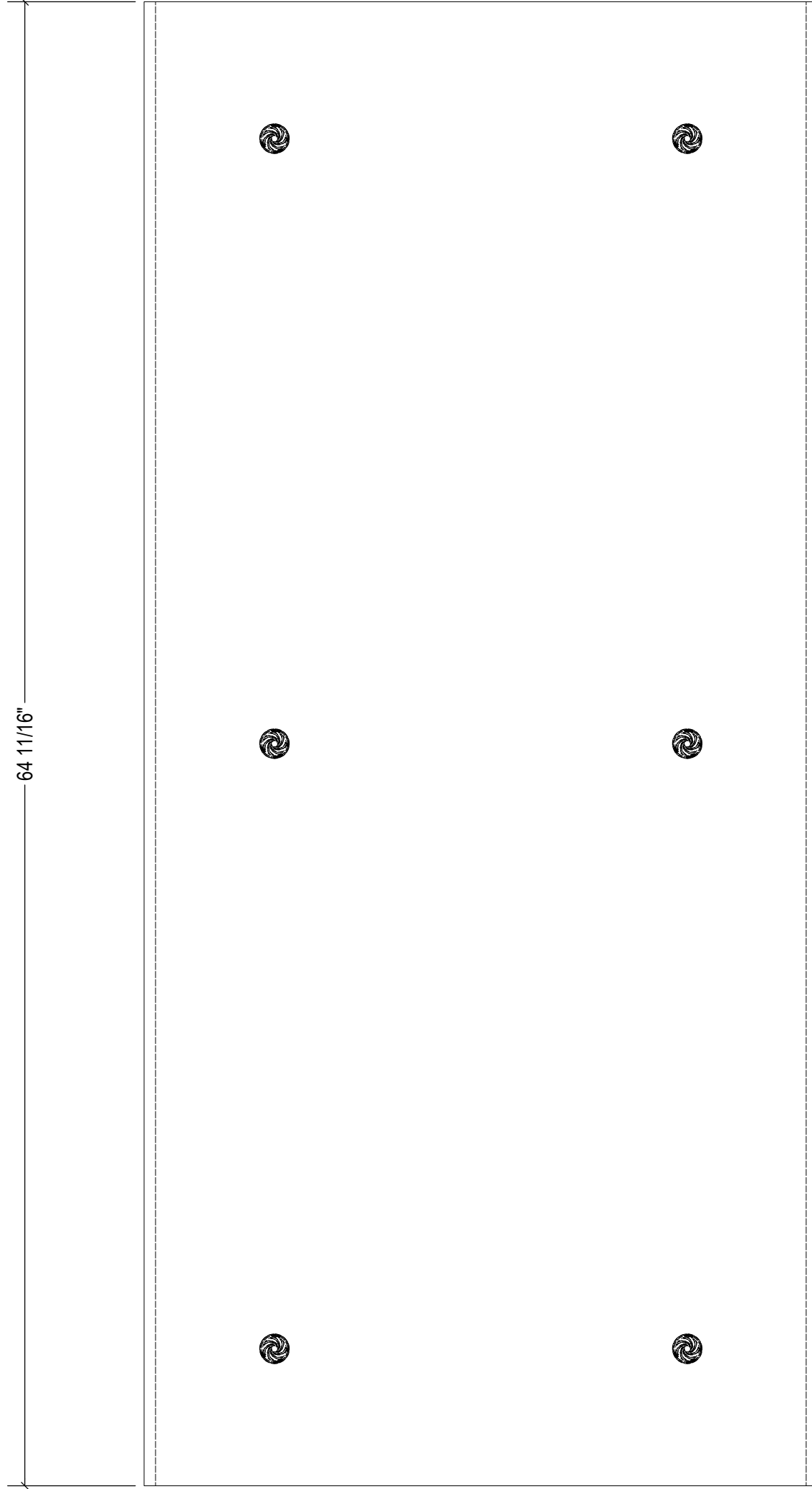

FRONT
SCALE 1/6



SIDE
SCALE 1/6



ISO
SCALE 1/6

NAPLES BEACH BOUTIQUE
NAPLES, FL

Description:
FINISH PNL ASM - 48 IN W/ CAB - CENTER



3939 WASHINGTON BOULEVARD BALTIMORE, MARYLAND 21227-4165
PH: (410) 242-0400 FX: (410) 242-0475
A DIVISION OF WEITZMAN INDUSTRIES, INC.

- REVISIONS -

BY	DATE	REMARKS

THIS DRAWING REMAINS THE PROPERTY OF DISPLAY CRAFT MFG CO. THE INFORMATION CONTAINED HEREON IS FOR THE SPECIFIC USE OF THE INDIVIDUAL PROJECT, AND MAY NOT BE USED FOR ANY OTHER PURPOSE WITHOUT THE WRITTEN CONSENT OF DISPLAY CRAFT MFG. CO.

FINISH SCHEDULE	
WD-4	PLYBOO VENEER - CARMELIZED FLAT CUT - 20% SHEEN CLEAR
WD-5	PLYBOO - CARMELIZED FLAT CUT - 20% SHEEN CLEAR
WC-2	PHILLIP JEFFRIES ISLAND - 7867 CAPRI NATURAL
LAM-1	HARD ROCK MAPLE
LT-1	STRIP LIGHTS 3000K

PARTS LIST										
ITEM	QTY	PART NUMBER	C.C.	DESCRIPTION	Length	Width	Thk.	Material	Finish	EB
1	6	3083-003A-YA-01	FC	INTERNAL RISER	17.655	1.25	0.76	Medium Density Fiberboard		N/A
2	1	3083-003A-YA-03	FC	FRONT	47	2	0.765	PLYBOO G2S	20% SHEEN CLEAR	1L
3	1	3083-003A-YA-04	FC	TOP	47	20.687	0.765	PLYBOO G2S	20% SHEEN CLEAR	N/A
4	1	3083-003A-YA-05	FC	LED RISER	45.47	1.25	0.765	PLYBOO G2S	20% SHEEN CLEAR	N/A
5	1	3083-003A-YA-06	FC	BOTTOM	45.47	18.422	0.25	PLYBOO G2S	20% SHEEN CLEAR	N/A
6	2	3083-003A-YA-02	FS	SIDE	20.187	1.5	0.765	PLYBOO G2S	20% SHEEN CLEAR	1L
7	2	3083-003A-YA-V01	FS	SIDE VENEER	20.687	2	0.023	PLYBOO G2S	20% SHEEN CLEAR	N/A
8	2	ADJ SHELF BRACKET	P	BRACKET						
9	8	SELF-MC45-AR01	P	SELF-MC45-AR	1.181	0.45	0.429	Steel Profile		N/A

DATE:	3/9/2026
DRAWN BY:	BH
FIXTURE NAME:	BB-01
PART #:	3083-003A-YA
JOB #:	3083
SHEET #:	003.36

NAPLES BEACH BOUTIQUE
NAPLES, FL

ADJUSTABLE SHELF - 48 INCH

Description:



3939 WASHINGTON BOULEVARD BALTIMORE, MARYLAND 21227-4165
PH: (410) 242-0400 FX: (410) 242-0475
A DIVISION OF WEITZMAN INDUSTRIES, INC.

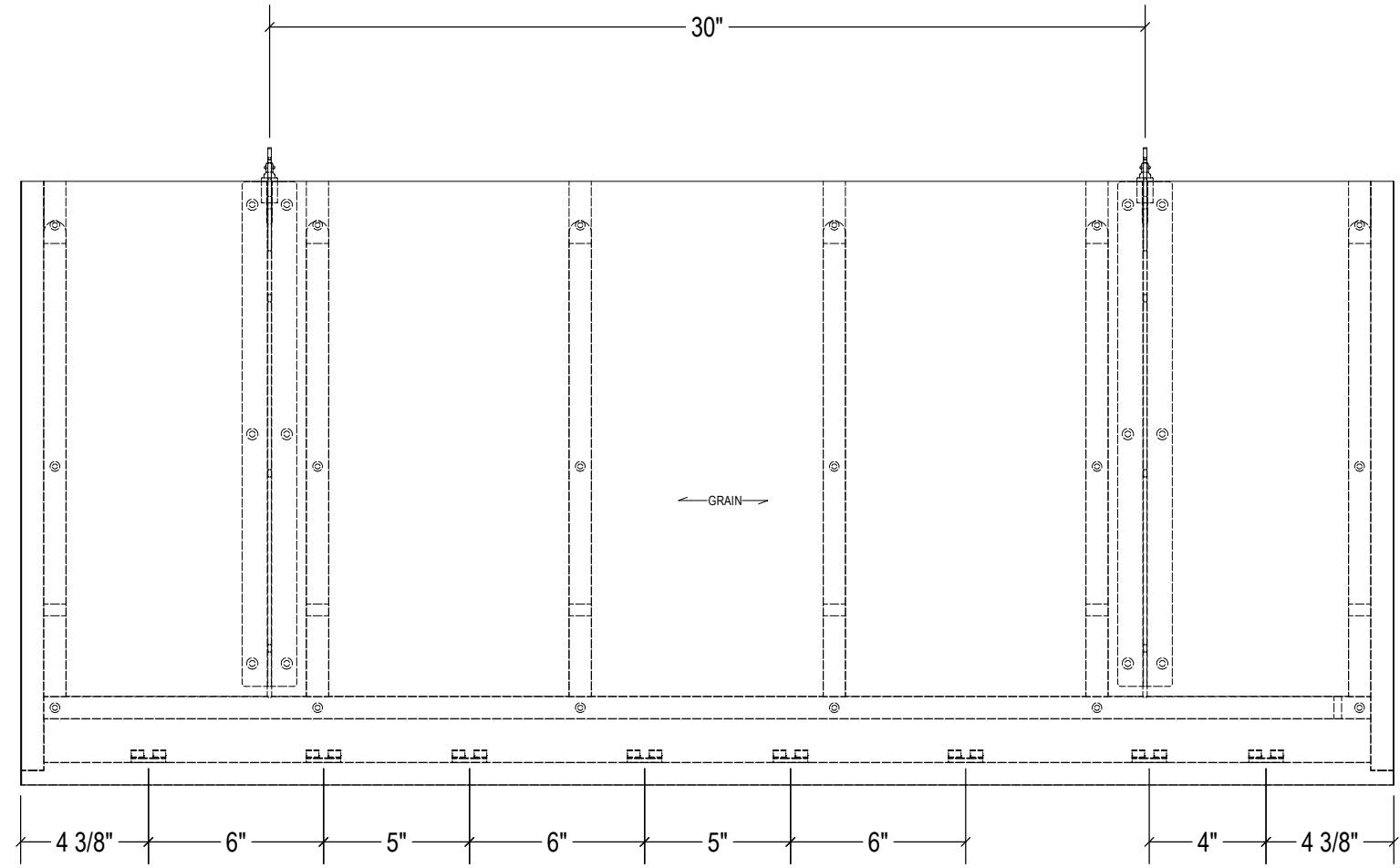

TOP
SCALE 1/6

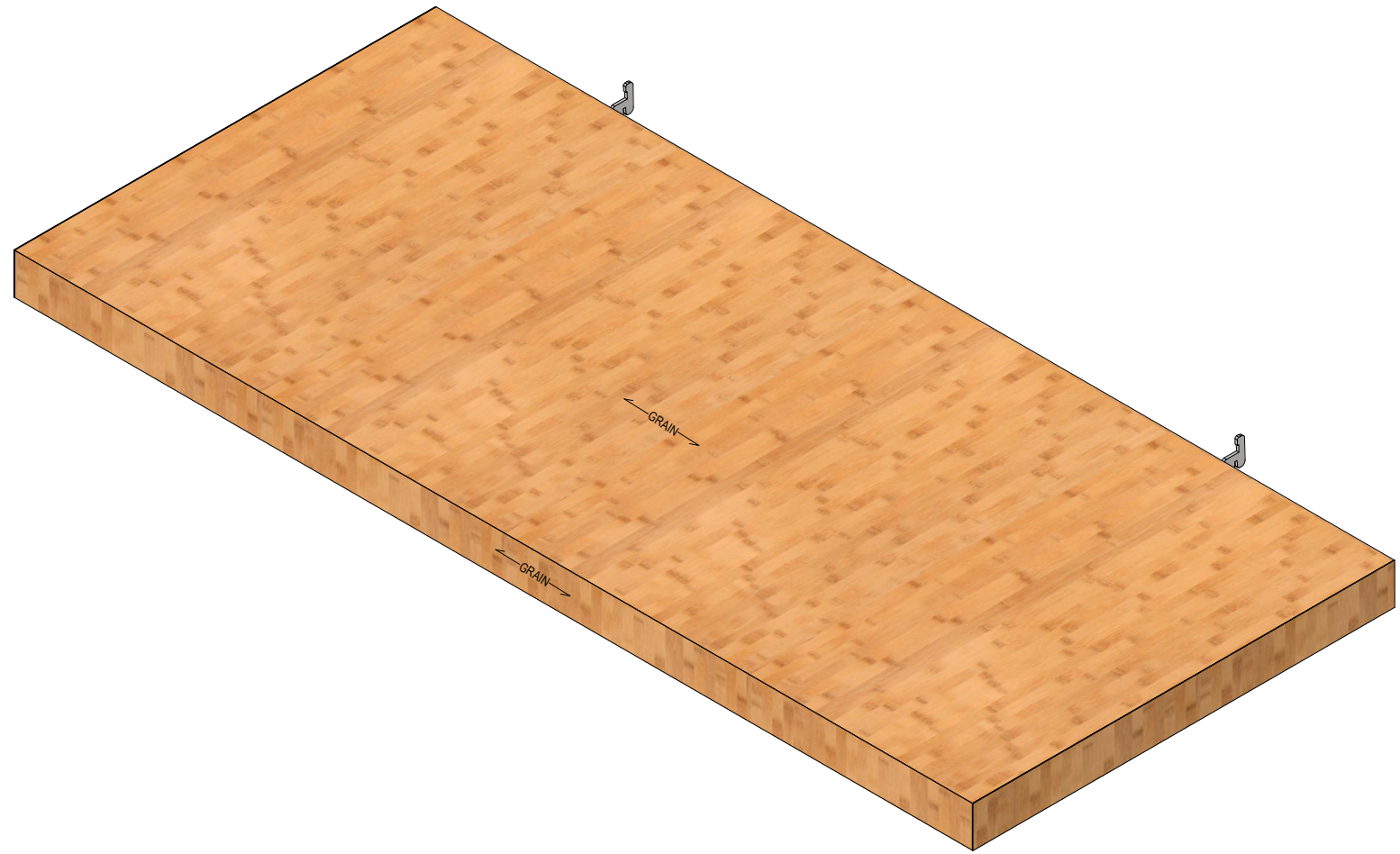

ISO
SCALE 1/6

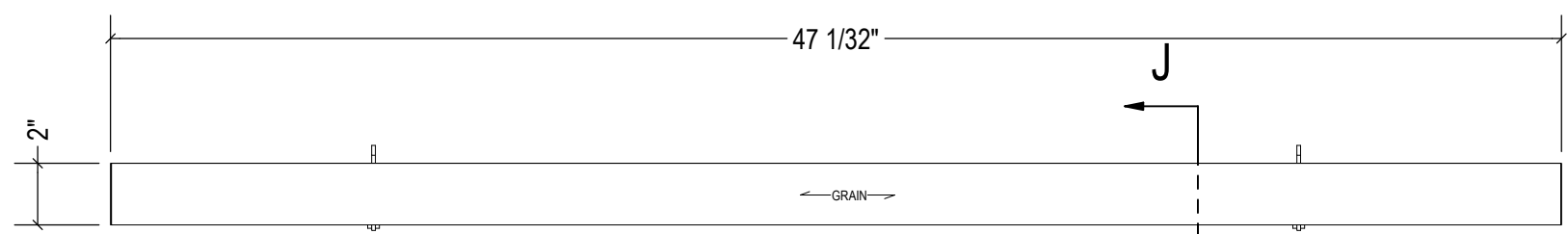

FRONT
SCALE 1/6

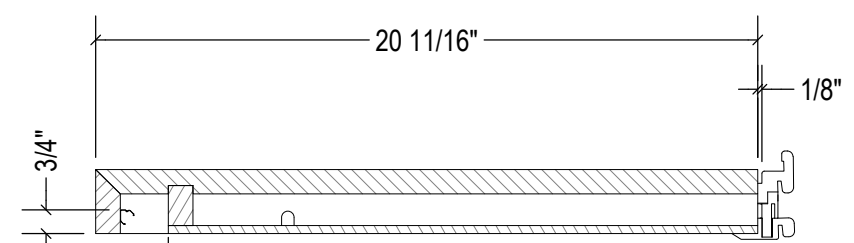

SECTION J
SCALE 1/6

- REVISIONS -

BY	DATE	REMARKS

THIS DRAWING REMAINS THE PROPERTY OF DISPLAY CRAFT MFG CO. THE INFORMATION CONTAINED HEREON IS FOR THE SPECIFIC USE OF THE INDIVIDUAL PROJECT, AND MAY NOT BE USED FOR ANY OTHER PURPOSE WITHOUT THE WRITTEN CONSENT OF DISPLAY CRAFT MFG. CO.

FINISH SCHEDULE	
WD-4	PLYBOO VENEER - CARMELIZED FLAT CUT - 20% SHEEN CLEAR
WD-5	PLYBOO - CARMELIZED FLAT CUT - 20% SHEEN CLEAR
WC-2	PHILLIP JEFFRIES ISLAND - 7867 CAPRI NATURAL
LAM-1	HARD ROCK MAPLE
LT-1	STRIP LIGHTS 3000K

PARTS LIST										
ITEM	QTY	PART NUMBER	C.C.	DESCRIPTION	Length	Width	Thk.	Material	Finish	EB
1	6	3083-003A-YA-01	FC	INTERNAL RISER	17.655	1.25	0.76	Medium Density Fiberboard		N/A
2	1	3083-003A-YA-03	FC	FRONT	47	2	0.765	PLYBOO G2S	20% SHEEN CLEAR	1L
3	1	3083-003A-YA-04	FC	TOP	47	20.687	0.765	PLYBOO G2S	20% SHEEN CLEAR	N/A
4	1	3083-003A-YA-05	FC	LED RISER	45.47	1.25	0.765	PLYBOO G2S	20% SHEEN CLEAR	N/A
5	1	3083-003A-YA-06	FC	BOTTOM	45.47	18.422	0.25	PLYBOO G2S	20% SHEEN CLEAR	N/A
6	2	3083-003A-YA-02	FS	SIDE	20.187	1.5	0.765	PLYBOO G2S	20% SHEEN CLEAR	1L
7	2	3083-003A-YA-V01	FS	SIDE VENEER	20.687	2	0.023	PLYBOO G2S	20% SHEEN CLEAR	N/A
8	2	ADJ SHELF BRACKET	P	BRACKET						
9	8	SELF-MC45-AR01	P	SELF-MC45-AR	1.181	0.45	0.429	Steel Profile		N/A

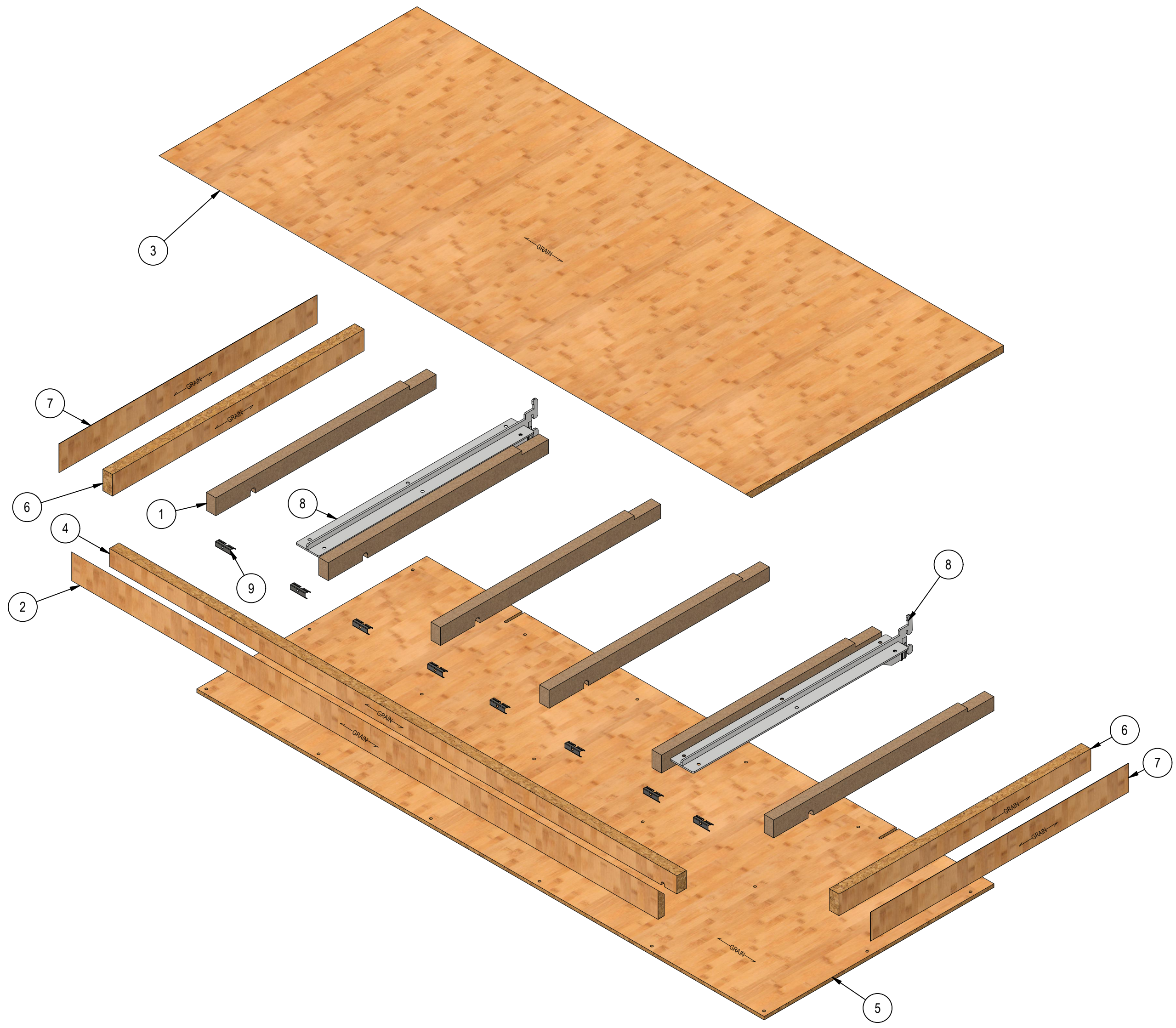

EXPLODED
SCALE 1/5

DATE:	3/9/2026
DRAWN BY:	BH
FIXTURE NAME:	BB-01
PART #:	3083-003A-YA
JOB #:	3083
SHEET #:	003.37

NAPLES BEACH BOUTIQUE
NAPLES, FL

ADJUSTABLE SHELF - 48 INCH



3959 WASHINGTON BOULEVARD BALTIMORE, MARYLAND 21227-4165
PH: (410) 242-0400 FX: (410) 242-0475
A DIVISION OF WEITZMAN INDUSTRIES, INC.

- REVISIONS -

BY	DATE	REMARKS

THIS DRAWING REMAINS THE PROPERTY OF DISPLAY CRAFT MFG CO. THE INFORMATION CONTAINED HEREON IS FOR THE SPECIFIC USE OF THE INDIVIDUAL PROJECT, AND MAY NOT BE USED FOR ANY OTHER PURPOSE WITHOUT THE WRITTEN CONSENT OF DISPLAY CRAFT MFG. CO.

FINISH SCHEDULE	
WD-4	PLYBOO VENEER - CARMELIZED FLAT CUT - 20% SHEEN CLEAR
WD-5	PLYBOO - CARMELIZED FLAT CUT - 20% SHEEN CLEAR
WC-2	PHILLIP JEFFRIES ISLAND - 7867 CAPRI NATURAL
LAM-1	HARD ROCK MAPLE
LT-1	STRIP LIGHTS 3000K

PARTS LIST										
ITEM	QTY	PART NUMBER	C.C.	DESCRIPTION	Length	Width	Thk.	Material	Finish	EB
1	6	3083-003A-YB-01	FC	RISER	17.655	1.25	0.76	Medium Density Fiberboard		N/A
2	1	3083-003A-YB-03	FC	FRONT	59	2	0.765	PLYBOO G2S	20% SHEEN CLEAR	1L
3	1	3083-003A-YB-04	FC	TOP	59	20.687	0.765	PLYBOO G2S	20% SHEEN CLEAR	N/A
4	1	3083-003A-YB-05	FC	LED RISER	57.47	1.25	0.765	PLYBOO G2S	20% SHEEN CLEAR	N/A
5	1	3083-003A-YB-06	FC	BOTTOM	57.47	18.422	0.25	PLYBOO G2S	20% SHEEN CLEAR	N/A
6	2	3083-003A-YB-02	FS	SIDE	20.187	1.5	0.765	PLYBOO G2S	20% SHEEN CLEAR	1L
7	2	3083-003A-YB-V01	FS	SIDE VENEER	20.687	2	0.023	PLYBOO G2S	20% SHEEN CLEAR	N/A
8	2	ADJ SHELF BRACKET	P	BRACKET						
9	6	SELF-MC45-AR01	P	SELF-MC45-AR	1.181	0.45	0.429	Steel Profile		N/A

DATE:	3/9/2026
DRAWN BY:	BH
FIXTURE NAME:	BB-01
PART #:	3083-003A-YB
JOB #:	3083
SHEET #:	003.38

NAPLES BEACH BOUTIQUE
NAPLES, FL

ADJUSTABLE SHELF - 60 INCH

Description:



3959 WASHINGTON BOULEVARD BALTIMORE, MARYLAND 21227-4165
PH: (410) 242-0400 FX: (410) 242-0475
A DIVISION OF WEITZMAN INDUSTRIES, INC.

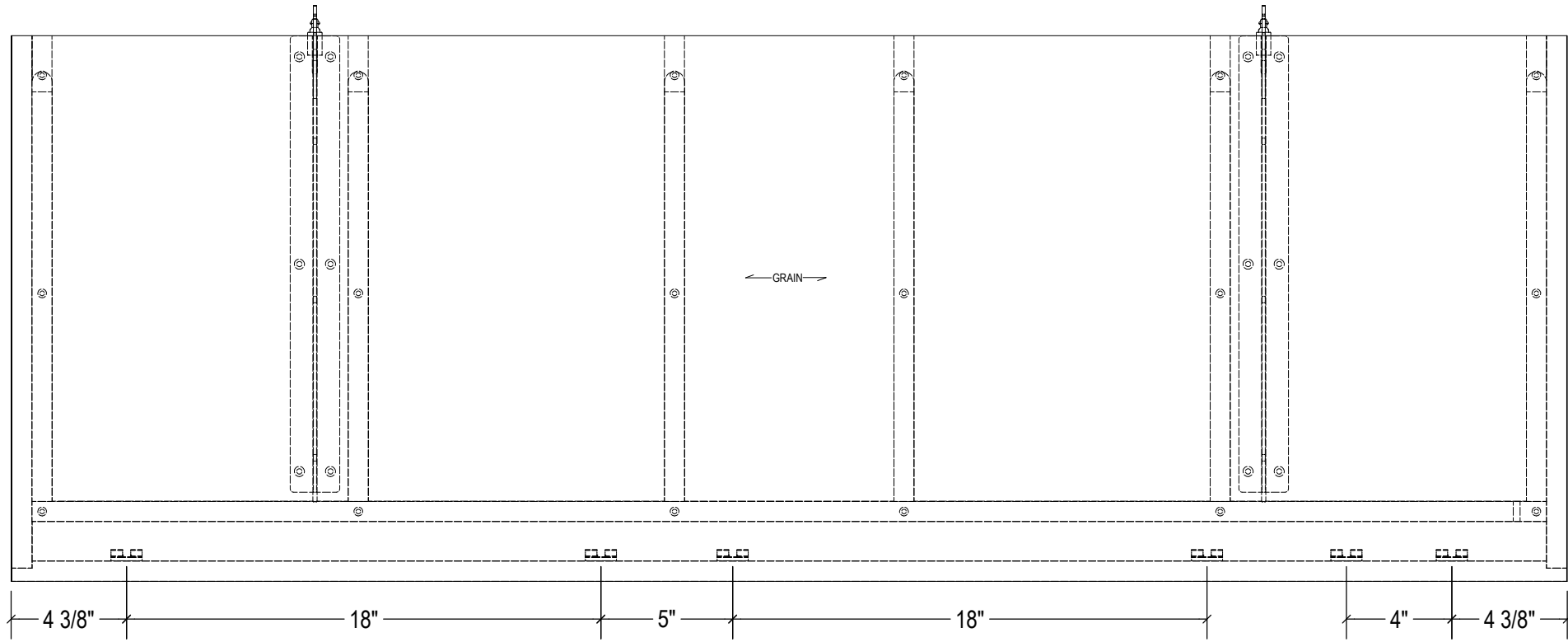

TOP
SCALE 1/6

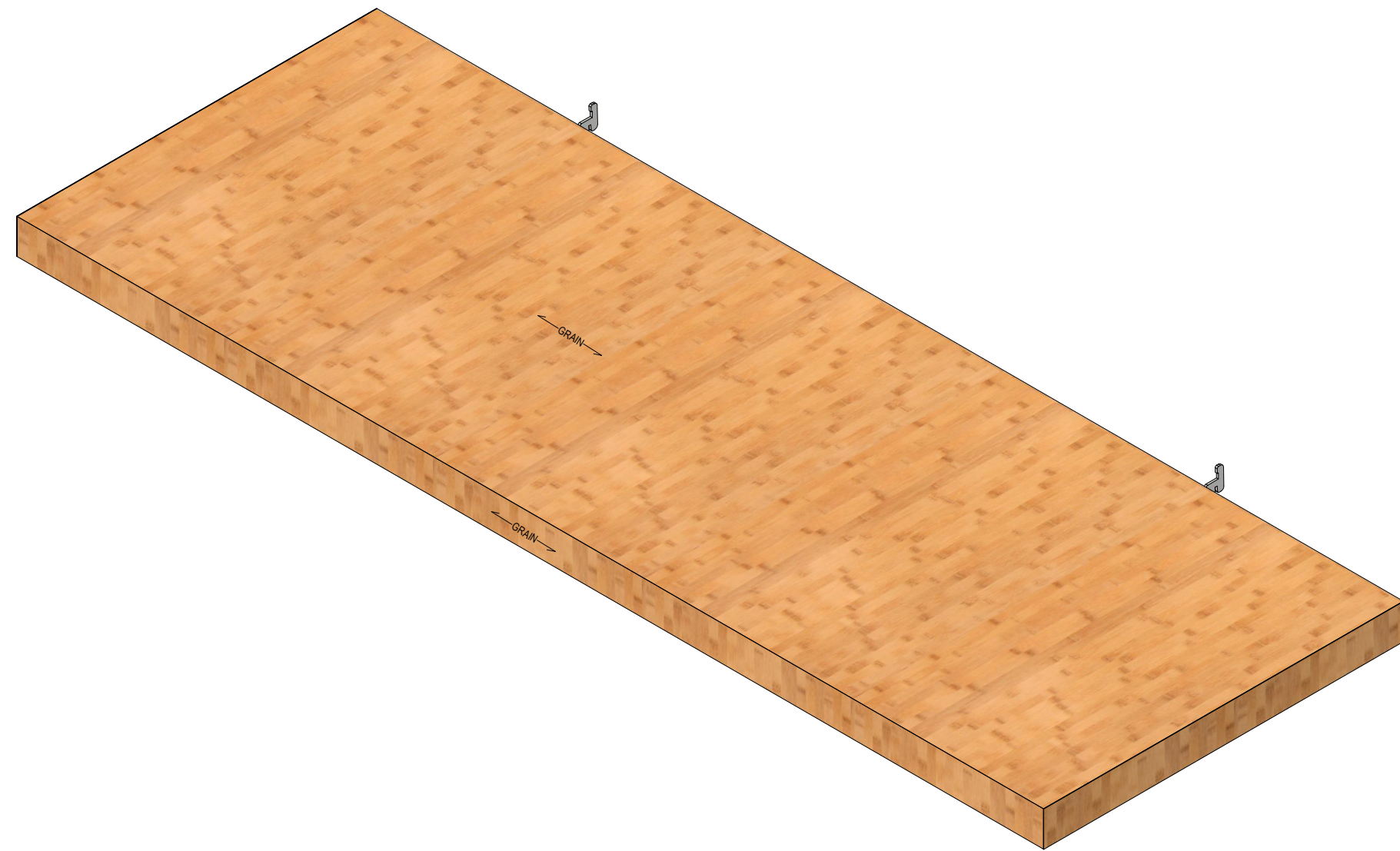

ISO
SCALE 1/6

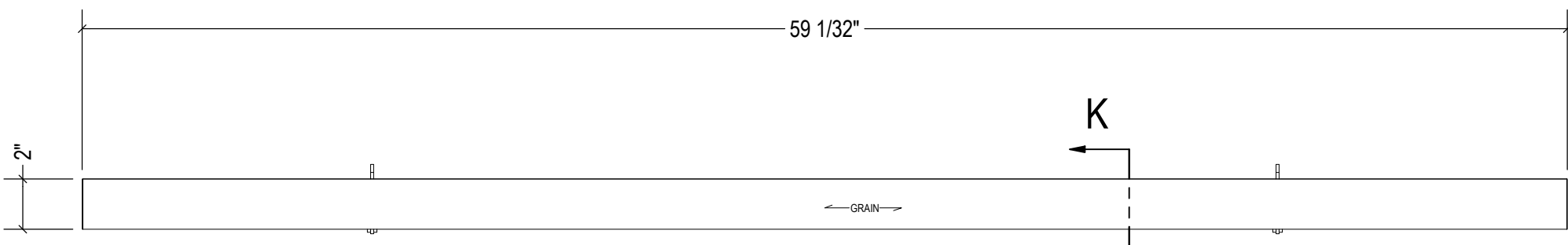

FRONT
SCALE 1/6

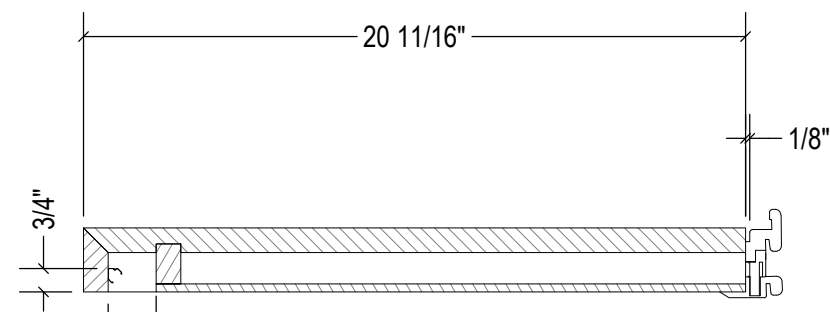

SECTION K
SCALE 1/6

- REVISIONS -

BY	DATE	REMARKS

THIS DRAWING REMAINS THE PROPERTY OF DISPLAY CRAFT MFG. CO. THE INFORMATION CONTAINED HEREON IS FOR THE SPECIFIC USE OF THE INDIVIDUAL PROJECT, AND MAY NOT BE USED FOR ANY OTHER PURPOSE WITHOUT THE WRITTEN CONSENT OF DISPLAY CRAFT MFG. CO.

FINISH SCHEDULE	
WD-4	PLYBOO VENEER - CARMELIZED FLAT CUT - 20% SHEEN CLEAR
WD-5	PLYBOO - CARMELIZED FLAT CUT - 20% SHEEN CLEAR
WC-2	PHILLIP JEFFRIES ISLAND - 7867 CAPRI NATURAL
LAM-1	HARD ROCK MAPLE
LT-1	STRIP LIGHTS 3000K

PARTS LIST										
ITEM	QTY	PART NUMBER	C.C.	DESCRIPTION	Length	Width	Thk.	Material	Finish	EB
1	6	3083-003A-YB-01	FC	RISER	17.655	1.25	0.76	Medium Density Fiberboard		N/A
2	1	3083-003A-YB-03	FC	FRONT	59	2	0.765	PLYBOO G2S	20% SHEEN CLEAR	1L
3	1	3083-003A-YB-04	FC	TOP	59	20.687	0.765	PLYBOO G2S	20% SHEEN CLEAR	N/A
4	1	3083-003A-YB-05	FC	LED RISER	57.47	1.25	0.765	PLYBOO G2S	20% SHEEN CLEAR	N/A
5	1	3083-003A-YB-06	FC	BOTTOM	57.47	18.422	0.25	PLYBOO G2S	20% SHEEN CLEAR	N/A
6	2	3083-003A-YB-02	FS	SIDE	20.187	1.5	0.765	PLYBOO G2S	20% SHEEN CLEAR	1L
7	2	3083-003A-YB-V01	FS	SIDE VENEER	20.687	2	0.023	PLYBOO G2S	20% SHEEN CLEAR	N/A
8	2	ADJ SHELF BRACKET	P	BRACKET						
9	6	SELF-MC45-AR01	P	SELF-MC45-AR	1.181	0.45	0.429	Steel Profile		N/A

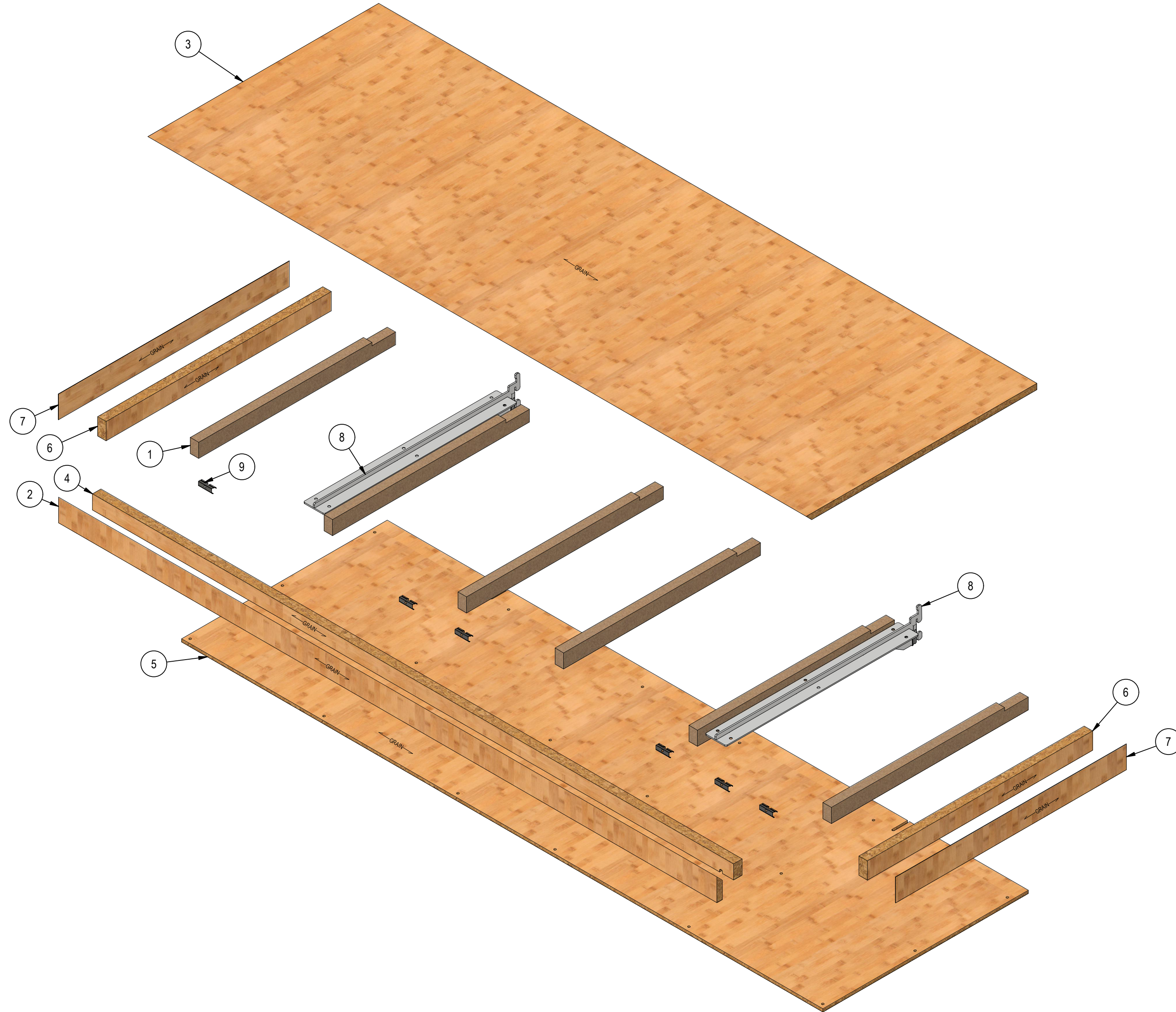

EXPLODED
SCALE 1/5

DATE: 3/9/2026
 DRAWN BY: BH
 FIXTURE NAME: BB-01
 PART #: 3083-003A-YB
 JOB #: 3083
 SHEET #: 003.39

NAPLES BEACH BOUTIQUE
NAPLES, FL

Description: **ADJUSTABLE SHELF - 60 INCH**



3939 WASHINGTON BOULEVARD BALTIMORE, MARYLAND 21227-4165
 PH: (410) 242-0400 FX: (410) 242-0475
 A DIVISION OF WEITZMAN INDUSTRIES, INC.

- REVISIONS -

BY	DATE	REMARKS

THIS DRAWING REMAINS THE PROPERTY OF DISPLAY CRAFT MFG CO. THE INFORMATION CONTAINED HEREON IS FOR THE SPECIFIC USE OF THE INDIVIDUAL PROJECT, AND MAY NOT BE USED FOR ANY OTHER PURPOSE WITHOUT THE WRITTEN CONSENT OF DISPLAY CRAFT MFG. CO.