





PARTS LIST										
ITEM	QTY	PART NUMBER	C.C.	DESCRIPTION	Length	Width	Thk.	Material	Finish	EB
1	1	3083-003-AA-01	FC	SHORT LEFT	92.75	4.747	0.765	PLYBOO G2S	20% SHEEN CLEAR	N/A
2	1	3083-003-AA-02	FC	FRONT	92.75	3	0.765	PLYBOO G2S	20% SHEEN CLEAR	N/A
3	1	3083-003-AA-03	FC	RIGHT	92.75	23.75	0.765	PLYBOO G2S	20% SHEEN CLEAR	N/A
4	2	3083-003-AA-04	FS	SPACER	92.75	2	0.76	Medium Density Fiberboard		N/A
5	4	BUTTON_FIX-BUTTON-01	P	BUTTON FIX - BUTTON						N/A

DATE:	3/4/2026
DRAWN BY:	BH
FIXTURE NAME:	BB-03
PART #:	3083-BB03-AA
JOB #:	3083
SHEET #:	003.3

NAPLES BEACH BOUTIQUE  
NAPLES, FL

PILASTER LEFT LOWER

Description:



3959 WASHINGTON BOULEVARD BALTIMORE, MARYLAND 21227-4165  
PH: (410) 242-0400 FX: (410) 242-0475  
A DIVISION OF WEITZMAN INDUSTRIES, INC.

- REVISIONS -

BY	DATE	REMARKS

THIS DRAWING REMAINS THE PROPERTY OF DISPLAY CRAFT MFG. CO. THE INFORMATION CONTAINED HEREON IS FOR THE SPECIFIC USE OF THE INDIVIDUAL PROJECT, AND MAY NOT BE USED FOR ANY OTHER PURPOSE WITHOUT THE WRITTEN CONSENT OF DISPLAY CRAFT MFG. CO.

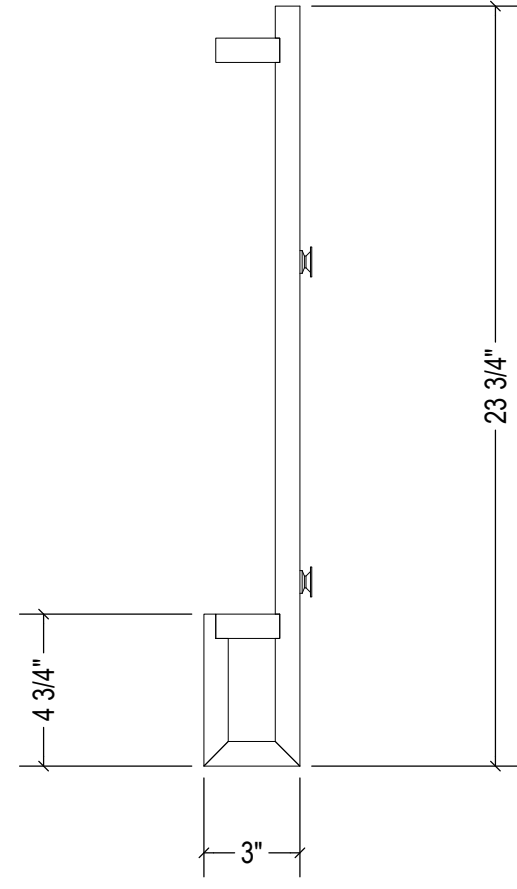

TOP  
SCALE 1/6

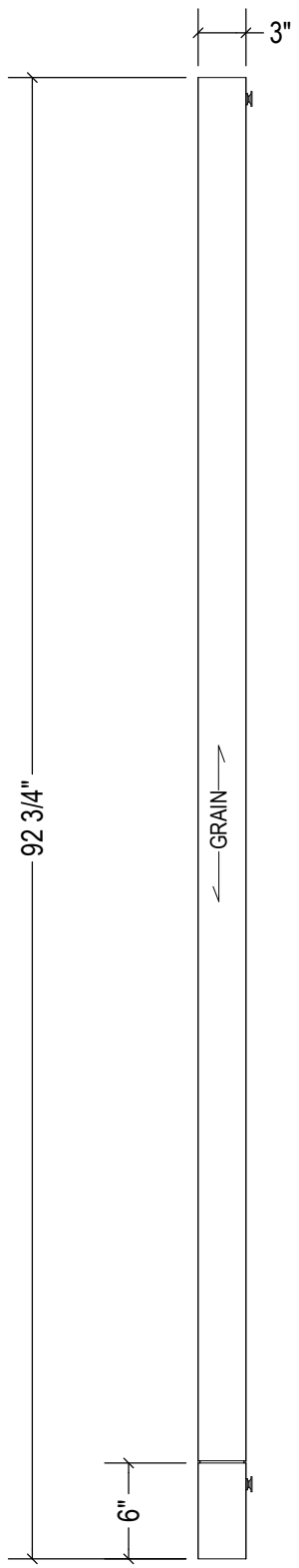

FRONT  
SCALE 1/12

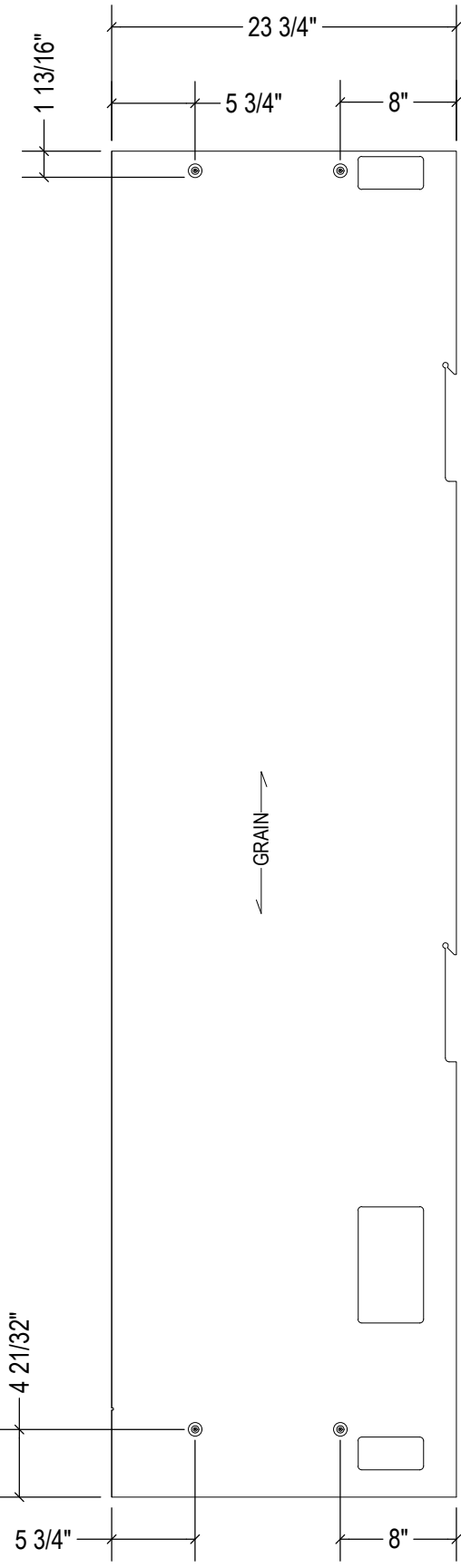

RIGHT  
SCALE 1/12

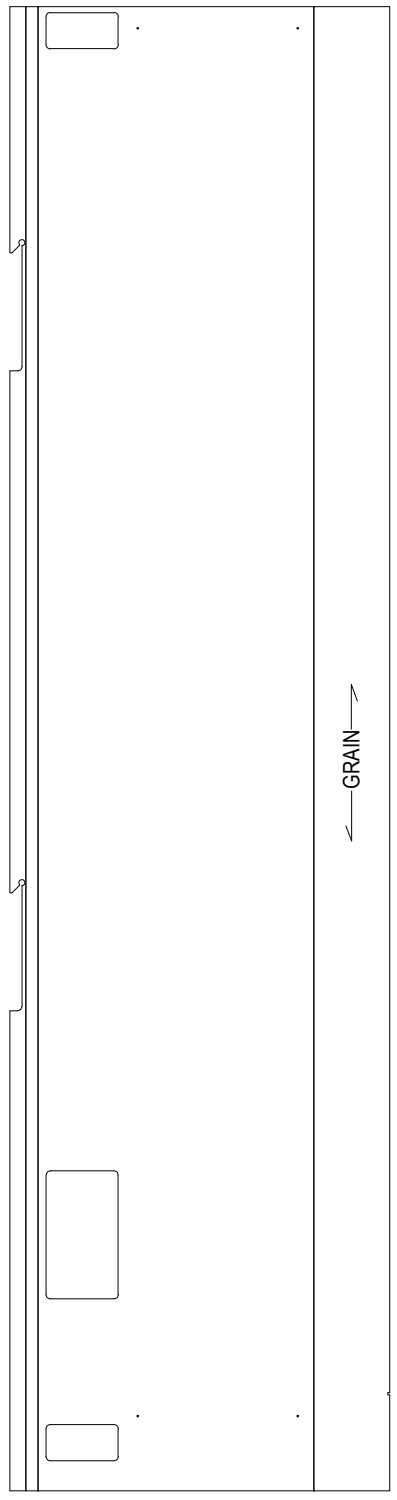

LEFT  
SCALE 1/12



LEFT ISO  
SCALE 1/12



RIGHT ISO  
SCALE 1/12

PARTS LIST											
ITEM	QTY	PART NUMBER	C.C.	DESCRIPTION	Length	Width	Thk.	Material	Finish	EB	
1	1	3083-003-AB-001	FC	SHORT LEFT	29	4.747	0.765	PLYBOO G2S	20% SHEEN CLEAR	N/A	
2	1	3083-003-AB-002	FC	FRONT	29	3	0.765	PLYBOO G2S	20% SHEEN CLEAR	N/A	
3	1	3083-003-AB-003	FC	RIGHT	29	23.75	0.765	PLYBOO G2S	20% SHEEN CLEAR	N/A	
4	2	3083-003-AB-005	FM	SPLICE	5.5	1.47	0.76	Medium Density Fiberboard		N/A	
5	2	3083-003-AB-004	FS	SPACER	29	2	0.76	Medium Density Fiberboard		N/A	
6	4	BUTTON_FIX-BUTTON-01	P	BUTTON FIX - BUTTON						N/A	
7	2	90295A150-01	P	NYLON WASHER	0.688	0.688	0.063	Solid Aluminum Piece		N/A	

DATE:	3/4/2026
DRAWN BY:	BH
FIXTURE NAME:	BB-03
PART #:	3083-BB03-AB
JOB #:	3083
SHEET #:	003.4

NAPLES BEACH BOUTIQUE  
NAPLES, FL

PILASTER LEFT UPPER

Description:



3939 WASHINGTON BOULEVARD BALTIMORE, MARYLAND 21227-4165  
PH: (410) 242-0400 FX: (410) 242-0475  
A DIVISION OF WEITZMAN INDUSTRIES, INC.

- REVISIONS -

BY	DATE	REMARKS

THIS DRAWING REMAINS THE PROPERTY OF DISPLAY CRAFT MFG CO. THE INFORMATION CONTAINED HEREON IS FOR THE SPECIFIC USE OF THE INDIVIDUAL PROJECT, AND MAY NOT BE USED FOR ANY OTHER PURPOSE WITHOUT THE WRITTEN CONSENT OF DISPLAY CRAFT MFG. CO.

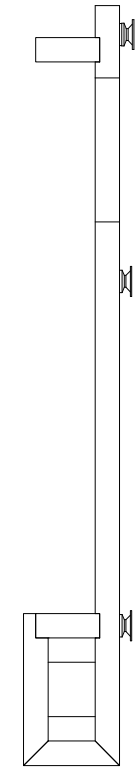

TOP  
SCALE 1/6

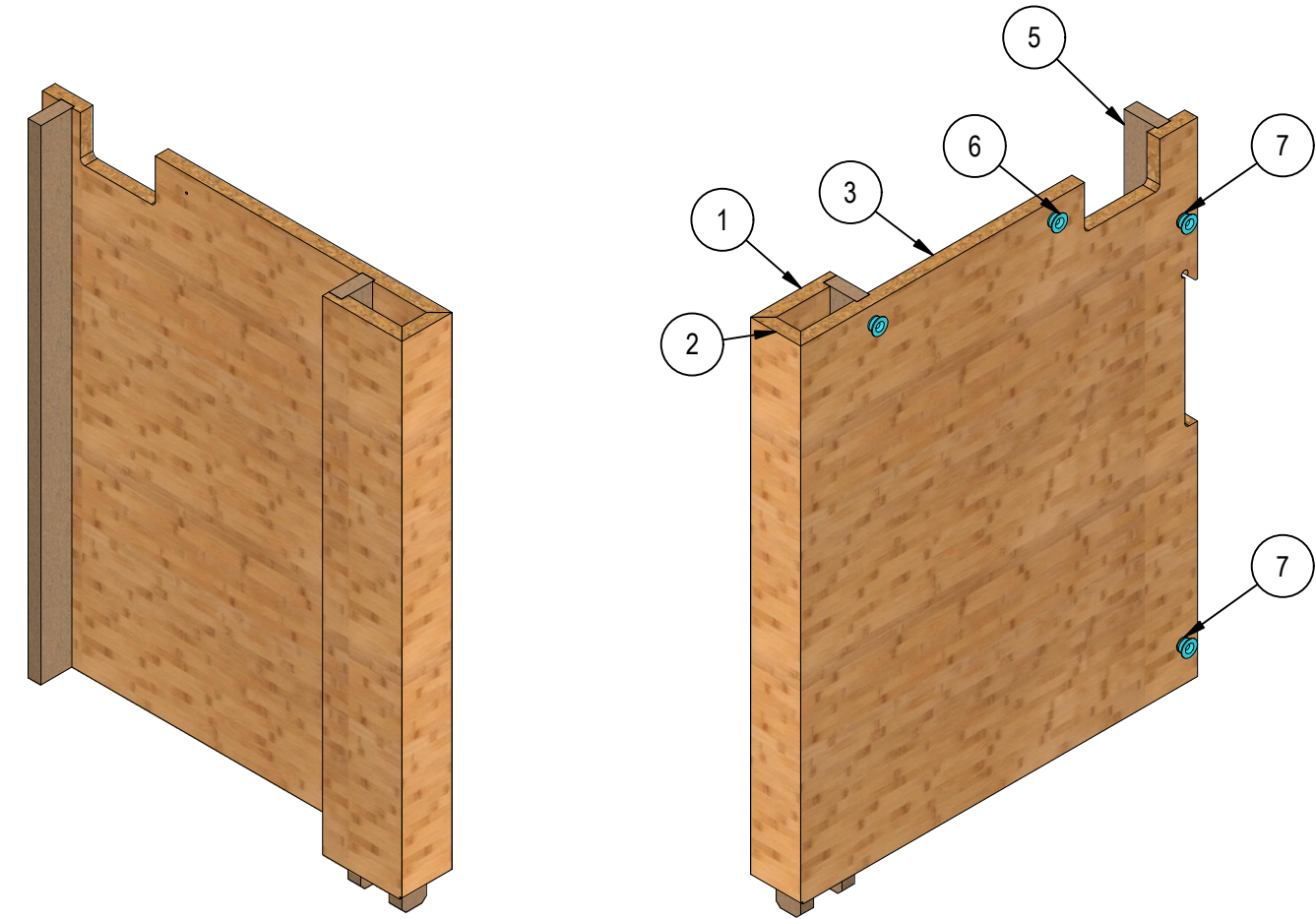

LEFT ISO  
SCALE 1/8

RIGHT ISO  
SCALE 1/8

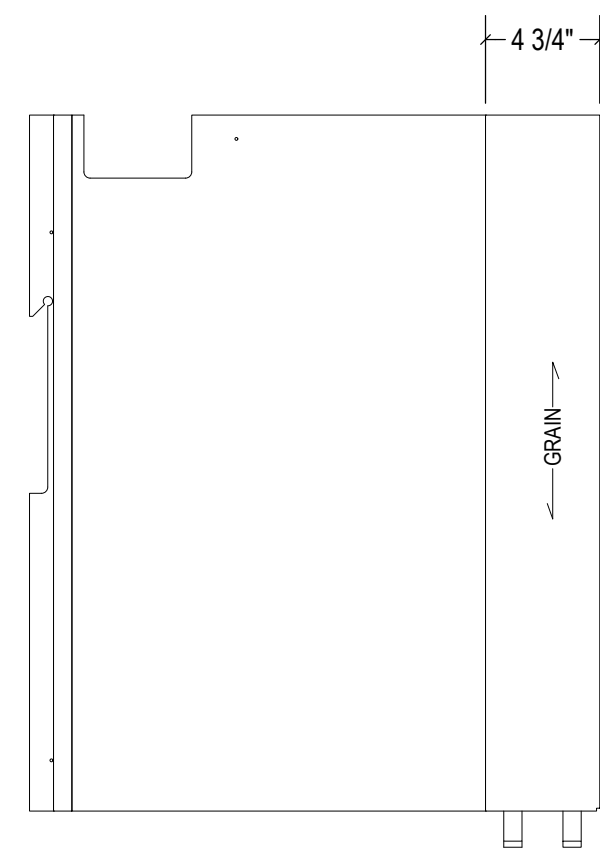

LEFT SIDE  
SCALE 1/8

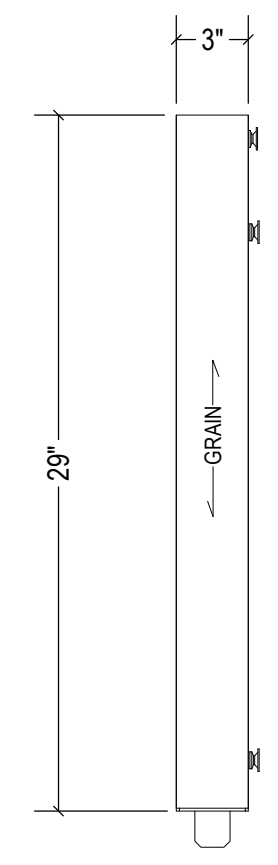

FRONT  
SCALE 1/8

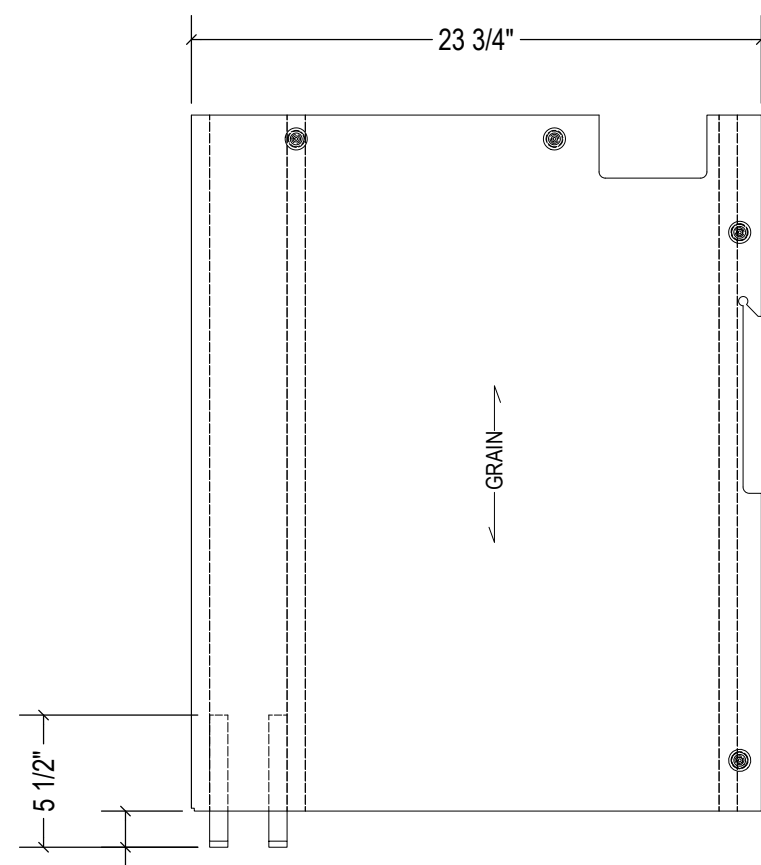

RIGHT SIDE  
SCALE 1/8

PARTS LIST										
ITEM	QTY	PART NUMBER	C.C.	DESCRIPTION	Length	Width	Thk.	Material	Finish	EB
1	1	3083-003-BA-01	FC	LEFT	92.75	23.75	0.765	PLYBOO G2S	20% SHEEN CLEAR	
2	1	3083-003-BA-02	FC	FRONT	92.75	3	0.765	PLYBOO G2S	20% SHEEN CLEAR	
3	1	3083-003-BA-03	FC	RIGHT	92.75	23.75	0.765	PLYBOO G2S	20% SHEEN CLEAR	
4	3	3083-003-BA-04	FS	SPACER	92.75	2	0.76	Medium Density Fiberboard		
5	8	BUTTON_FIX-BUTTON-01	P	BUTTON FIX - BUTTON						N/A

DATE:	3/4/2026
DRAWN BY:	BH
FIXTURE NAME:	BB-03
PART #:	3083-BB03-BA
JOB #:	3083
SHEET #:	003.5

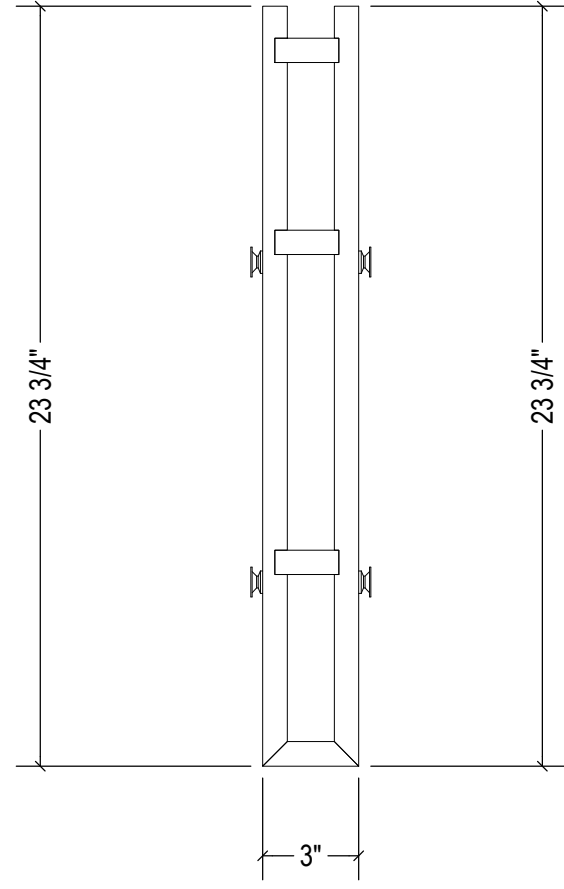

**TOP**  
SCALE 1 / 6

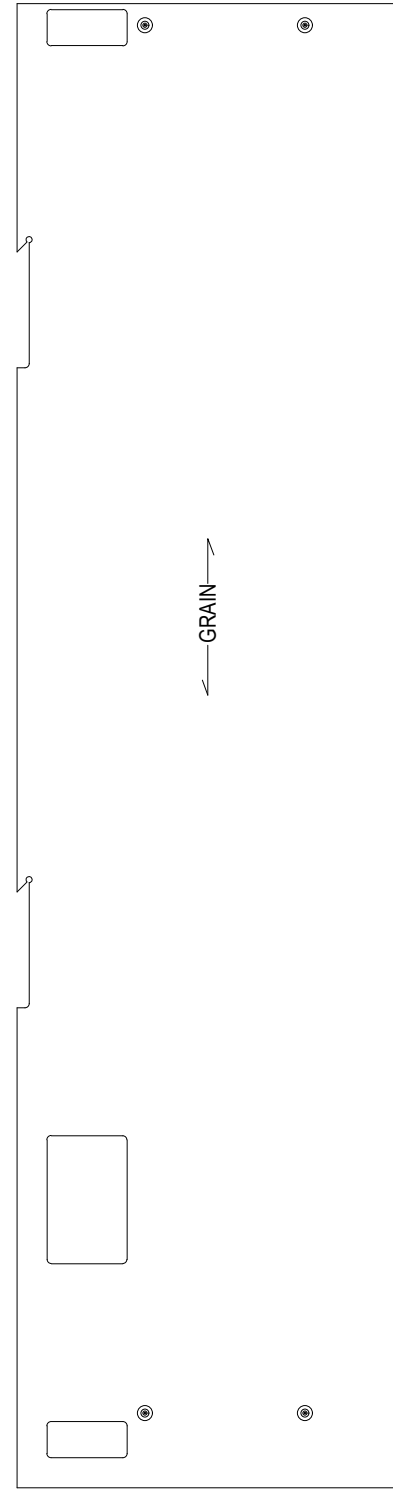

**LEFT SIDE**  
SCALE 1 / 12

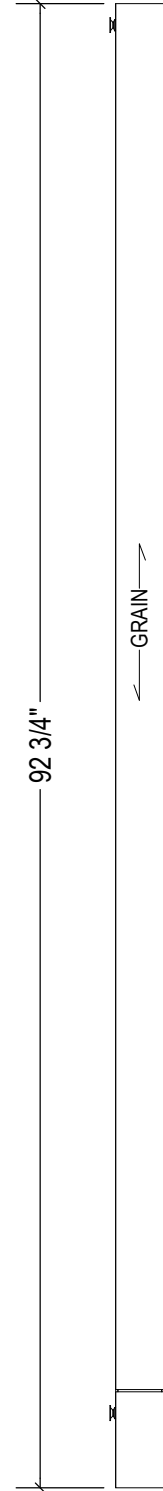

**FRONT**  
SCALE 1 / 12

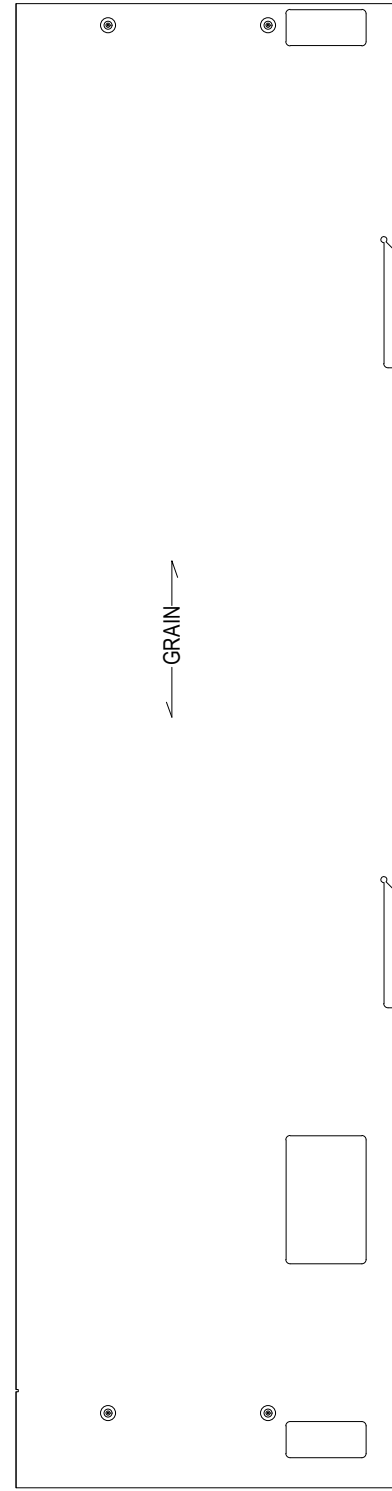

**RIGHT SIDE**  
SCALE 1 / 12

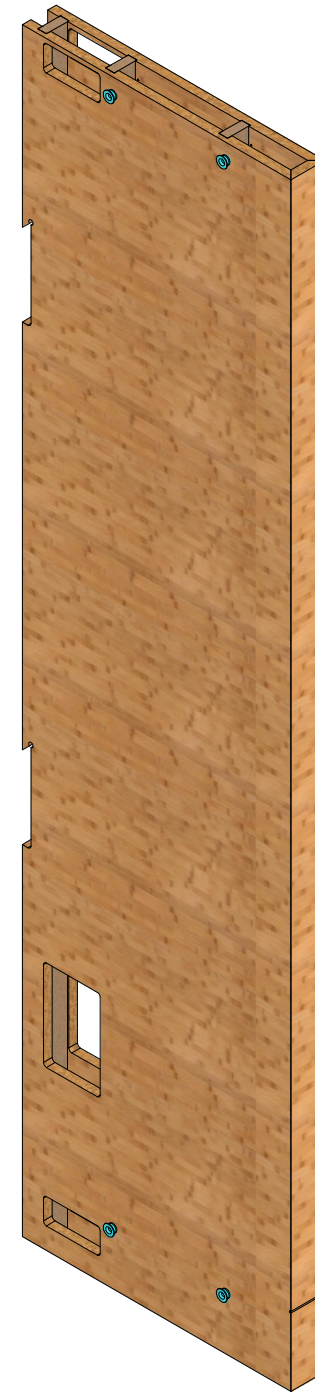

**LEFT ISO**  
SCALE 1 / 12



**RIGHT ISO**  
SCALE 1 / 12

NAPLES BEACH BOUTIQUE  
NAPLES, FL

Description:  
PILASTER CENTER LOWER, CAB BOTH



3939 WASHINGTON BOULEVARD BALTIMORE, MARYLAND 21227-4165  
PH: (410) 242-0400 FX: (410) 242-0475  
A DIVISION OF WEITZMAN INDUSTRIES, INC.

- REVISIONS -

BY	DATE	REMARKS

THIS DRAWING REMAINS THE PROPERTY OF DISPLAY CRAFT MFG CO. THE INFORMATION CONTAINED HEREON IS FOR THE SPECIFIC USE OF THE INDIVIDUAL PROJECT, AND MAY NOT BE USED FOR ANY OTHER PURPOSE WITHOUT THE WRITTEN CONSENT OF DISPLAY CRAFT MFG. CO.

ITEM	QTY	PART NUMBER	C.C.	DESCRIPTION	PARTS LIST			Material	Finish	EB
					Length	Width	Thk.			
1	1	3083-003-BB-001	FC	LEFT	29	23.75	0.765	PLYBOO G2S	20% SHEEN CLEAR	N/A
2	1	3083-003-BB-002	FC	FRONT	29	3	0.765	PLYBOO G2S	20% SHEEN CLEAR	N/A
3	1	3083-003-BB-003	FC	RIGHT	29	23.75	0.765	PLYBOO G2S	20% SHEEN CLEAR	N/A
4	2	3083-003-BB-005	FM	SPLICE	5.5	1.47	0.76	Medium Density Fiberboard		N/A
5	3	3083-003-BB-004	FS	SPACER	29	2	0.76	Medium Density Fiberboard		N/A
6	8	BUTTON_FIX-BUTTON-01	P	BUTTON FIX - BUTTON						N/A
7	4	90295A150-01	P	NYLON WASHER	0.688	0.688	0.063	Solid Aluminum Piece		N/A

DATE:	3/4/2026
DRAWN BY:	BH
FIXTURE NAME:	BB-03
PART #:	3083-BB03-BB
JOB #:	3083
SHEET #:	003.6

NAPLES BEACH BOUTIQUE  
NAPLES, FL

PILASTER CENTER UPPER

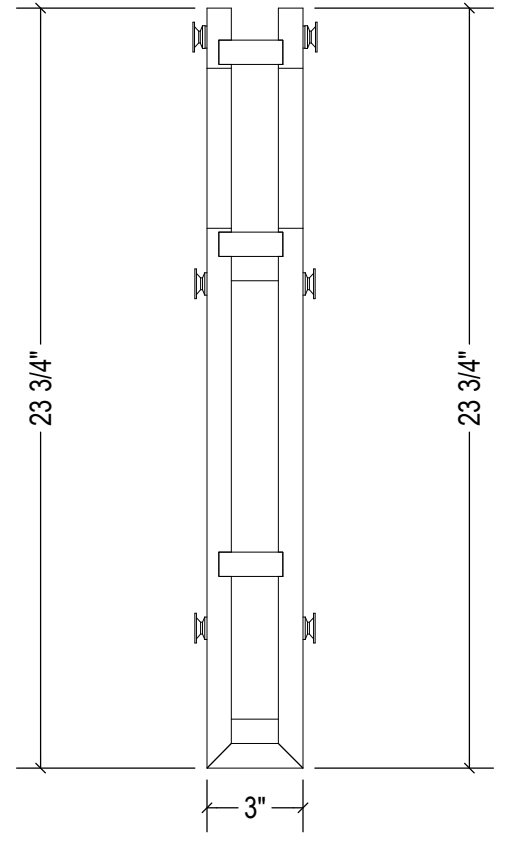

TOP  
SCALE 1 / 6



ISO LEFT  
SCALE 1 / 8

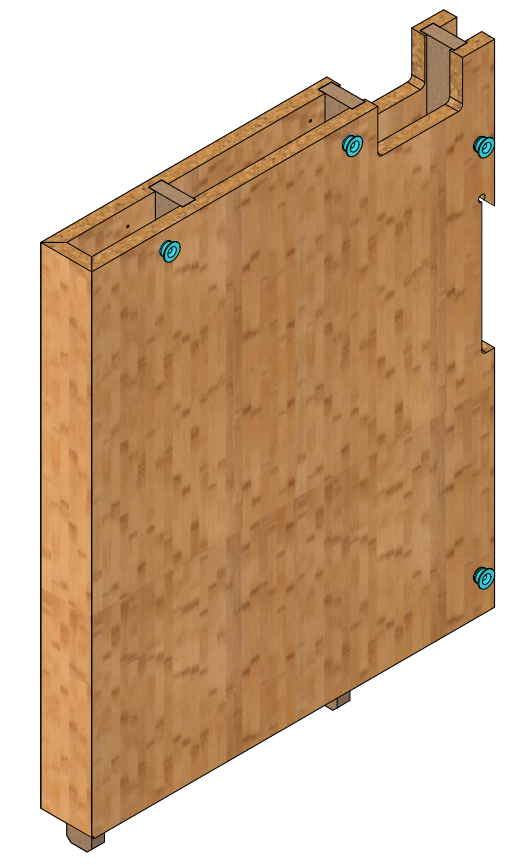

ISO RIGHT  
SCALE 1 / 8

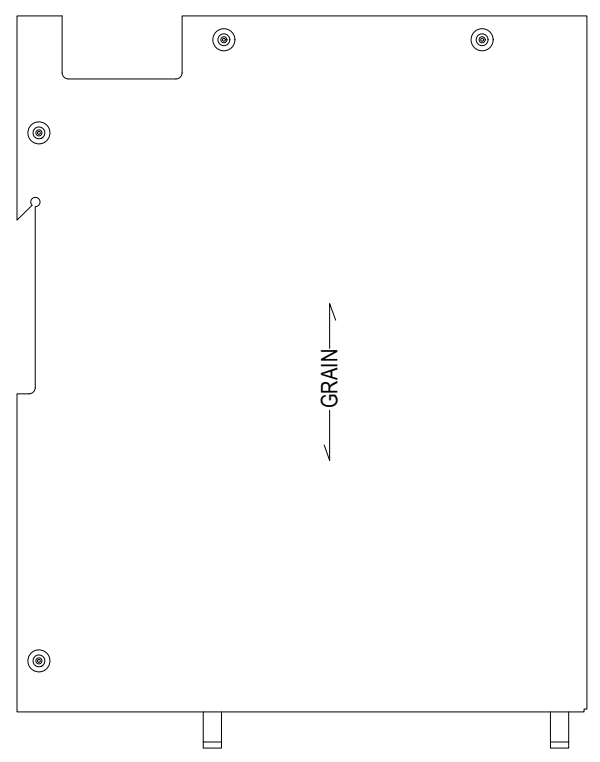

LEFT  
SCALE 1 / 8

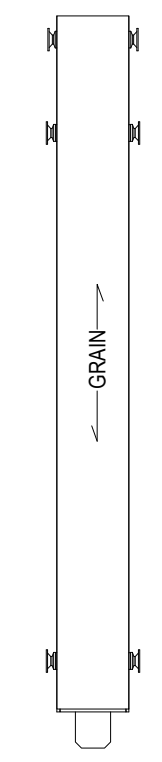

FRONT  
SCALE 1 / 8

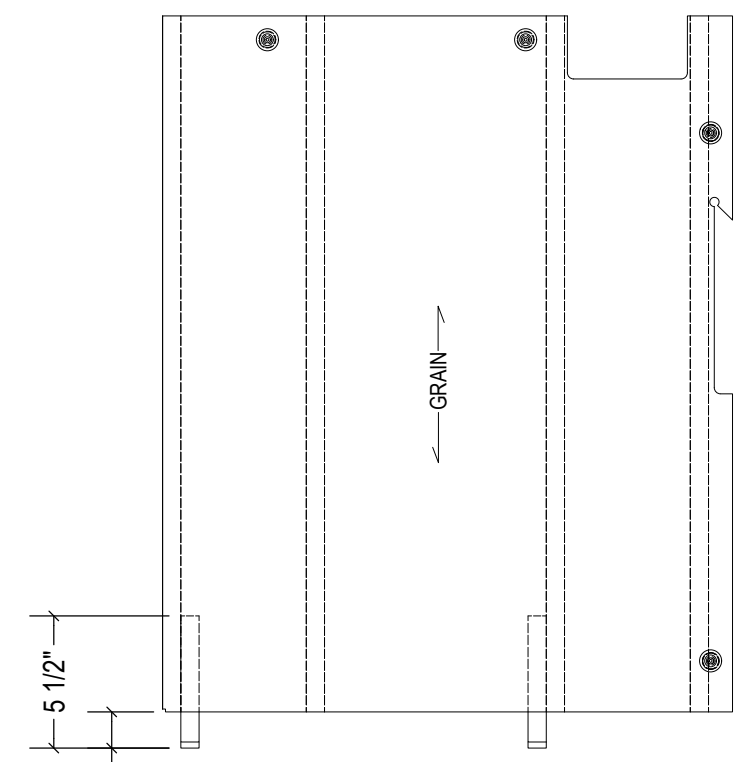

RIGHT  
SCALE 1 / 8



3939 WASHINGTON BOULEVARD BALTIMORE, MARYLAND 21227-4165  
PH: (410) 242-0400 FX: (410) 242-0475  
A DIVISION OF WEITZMAN INDUSTRIES, INC.

- REVISIONS -

BY	DATE	REMARKS

THIS DRAWING REMAINS THE PROPERTY OF DISPLAY CRAFT MFG. CO. THE INFORMATION CONTAINED HEREON IS FOR THE SPECIFIC USE OF THE INDIVIDUAL PROJECT, AND MAY NOT BE USED FOR ANY OTHER PURPOSE WITHOUT THE WRITTEN CONSENT OF DISPLAY CRAFT MFG. CO.

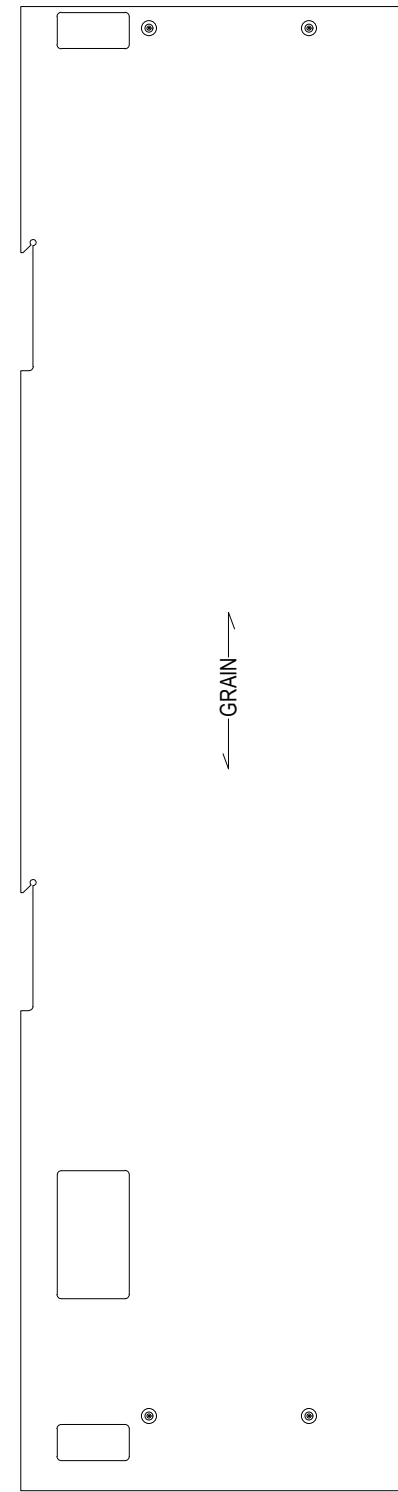

**LEFT**  
SCALE 1 / 12

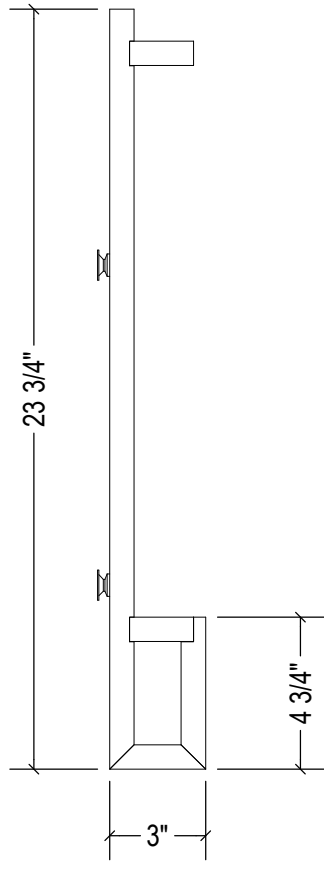

**TOP**  
SCALE 1 / 6

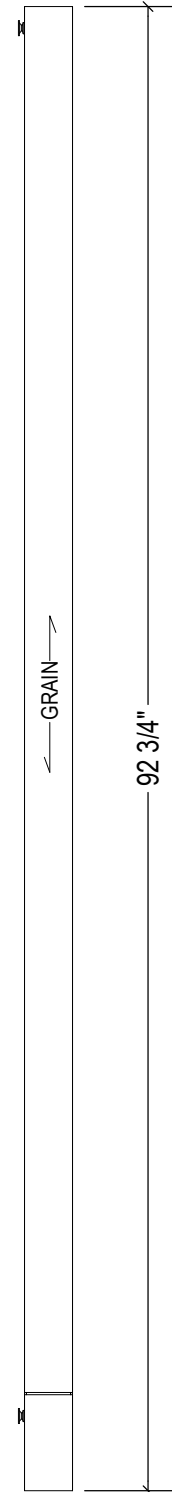

**FRONT**  
SCALE 1 / 12

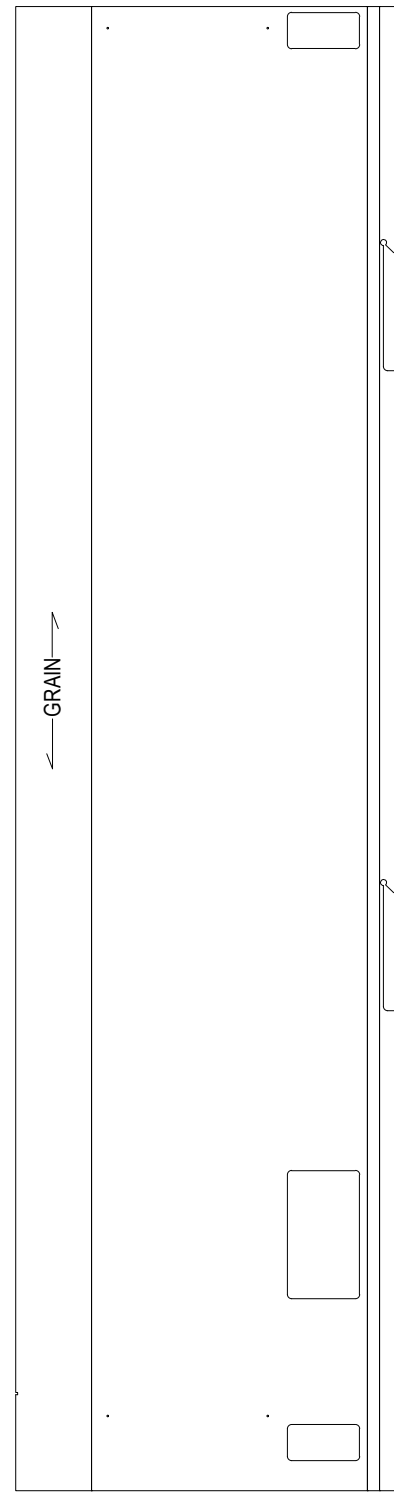

**RIGHT**  
SCALE 1 / 12



**LEFT ISO**  
SCALE 1 / 12

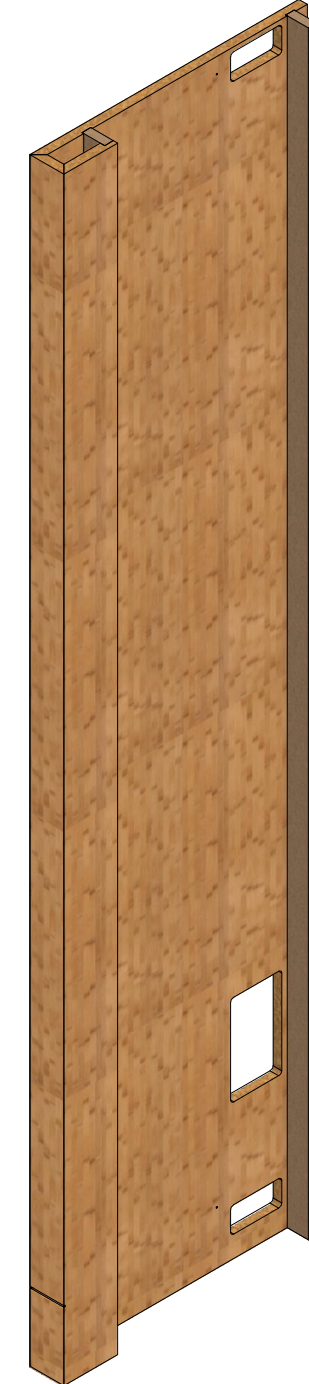

**RIGHT ISO**  
SCALE 1 / 12

PARTS LIST										
ITEM	QTY	PART NUMBER	C.C.	DESCRIPTION	Length	Width	Thk.	Material	Finish	EB
1	1	3083-003-CA-01	FC	LEFT	92.75	23.75	0.765	PLYBOO G2S	20% SHEEN CLEAR	N/A
2	1	3083-003-CA-02	FC	FRONT	92.75	3	0.765	PLYBOO G2S	20% SHEEN CLEAR	N/A
3	1	3083-003-CA-03	FC	RIGHT	92.75	4.747	0.765	PLYBOO G2S	20% SHEEN CLEAR	N/A
4	2	3083-003-CA-04	FS	SPACER	92.75	2	0.76	Medium Density Fiberboard		N/A
5	4	BUTTON_FIX-BUTTON-01	P	BUTTON FIX - BUTTON						N/A

DATE:	3/4/2026
DRAWN BY:	BH
FIXTURE NAME:	BB-03
PART #:	3083-BB03-CA
JOB #:	3083
SHEET #:	003.7

**NAPLES BEACH BOUTIQUE**  
**NAPLES, FL**

**PILASTER RIGHT LOWER**



3939 WASHINGTON BOULEVARD BALTIMORE, MARYLAND 21227-4165  
PH: (410) 242-0400 FX: (410) 242-0475  
A DIVISION OF WEITZMAN INDUSTRIES, INC.

- REVISIONS -

BY	DATE	REMARKS

THIS DRAWING REMAINS THE PROPERTY OF DISPLAY CRAFT MFG CO. THE INFORMATION CONTAINED HEREON IS FOR THE SPECIFIC USE OF THE INDIVIDUAL PROJECT, AND MAY NOT BE USED FOR ANY OTHER PURPOSE WITHOUT THE WRITTEN CONSENT OF DISPLAY CRAFT MFG. CO.

PARTS LIST										
ITEM	QTY	PART NUMBER	C.C.	DESCRIPTION	Length	Width	Thk.	Material	Finish	EB
1	1	3083-003-CB-001	FC	LEFT	29	23.75	0.765	PLYBOO G2S	20% SHEEN CLEAR	N/A
2	1	3083-003-CB-002	FC	FRONT	29	3	0.765	PLYBOO G2S	20% SHEEN CLEAR	N/A
3	1	3083-003-CB-003	FC	SHORT RIGHT	29	4.747	0.765	PLYBOO G2S	20% SHEEN CLEAR	N/A
4	2	3083-003-CB-005	FM	SPLICE	5.5	1.47	0.76	Medium Density Fiberboard		N/A
5	2	3083-003-CB-004	FS	SPACER	29	2	0.76	Medium Density Fiberboard		N/A
6	2	90295A150-01	P	NYLON WASHER	0.688	0.688	0.063			N/A
7	4	BUTTON_FIX-BUTTON-01	P	BUTTON FIX - BUTTON						N/A

DATE:	3/4/2026
DRAWN BY:	BH
FIXTURE NAME:	BB-03
PART #:	3083-BB03-CB
JOB #:	3083
SHEET #:	003.8

NAPLES BEACH BOUTIQUE  
NAPLES, FL

PILASTER RIGHT UPPER

Description:



3939 WASHINGTON BOULEVARD BALTIMORE, MARYLAND 21227-4165  
PH: (410) 242-0400 FX: (410) 242-0475  
A DIVISION OF WEITZMAN INDUSTRIES, INC.

- REVISIONS -

BY	DATE	REMARKS

THIS DRAWING REMAINS THE PROPERTY OF DISPLAY CRAFT MFG CO. THE INFORMATION CONTAINED HEREON IS FOR THE SPECIFIC USE OF THE INDIVIDUAL PROJECT, AND MAY NOT BE USED FOR ANY OTHER PURPOSE WITHOUT THE WRITTEN CONSENT OF DISPLAY CRAFT MFG. CO.

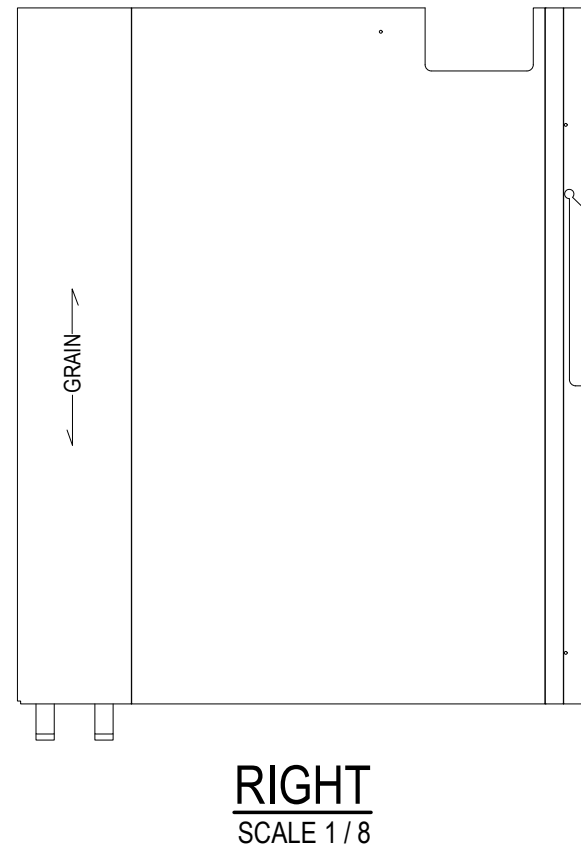
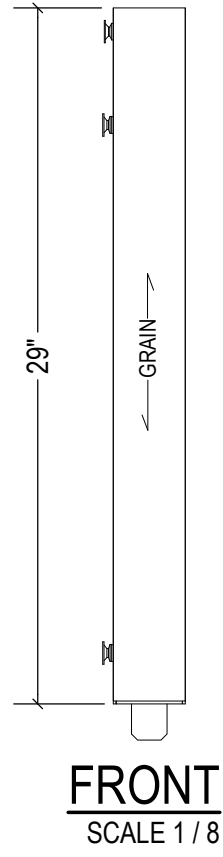
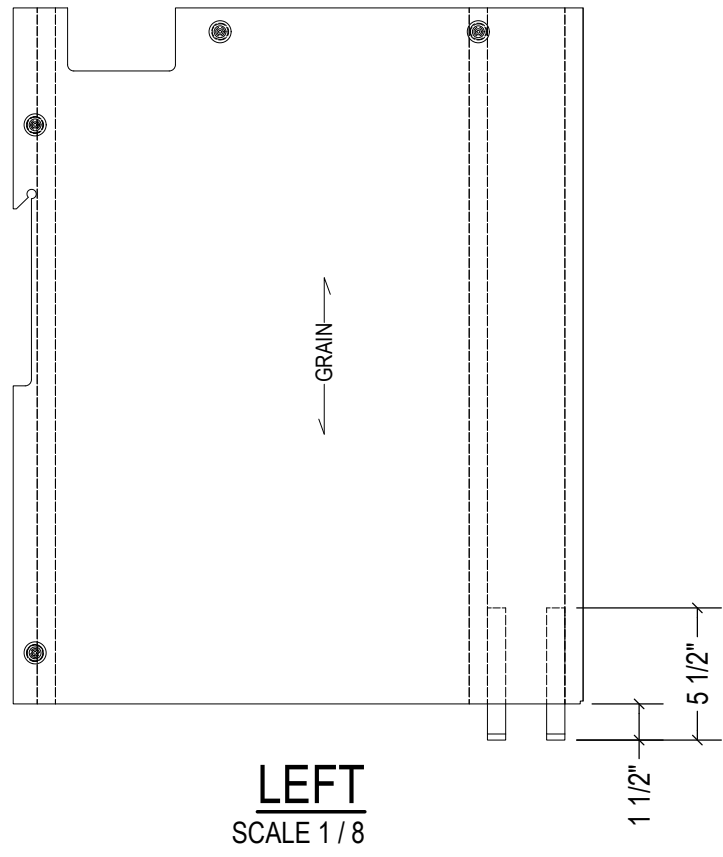
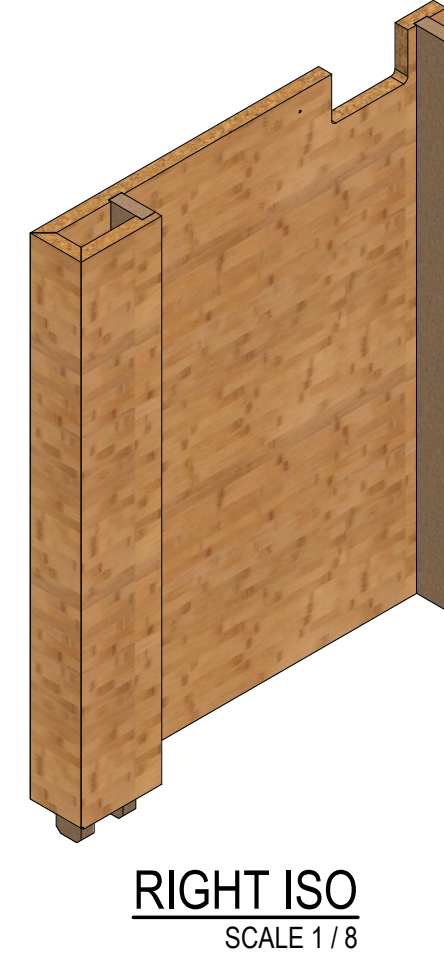
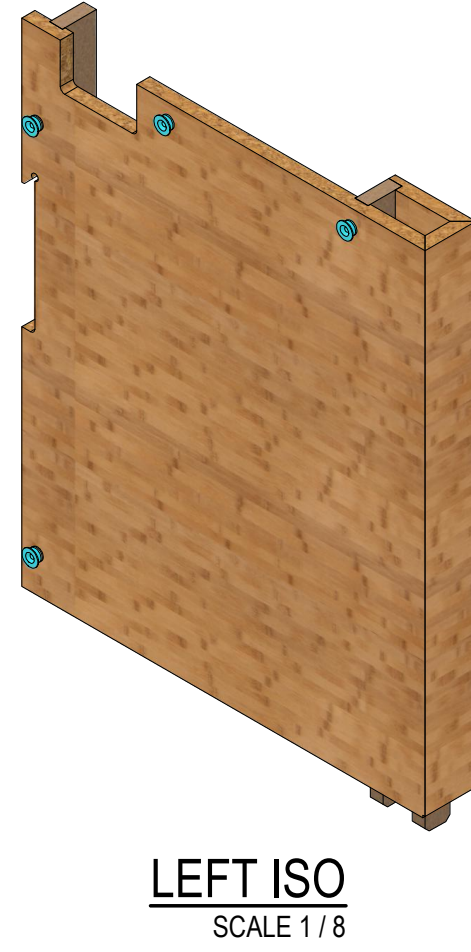
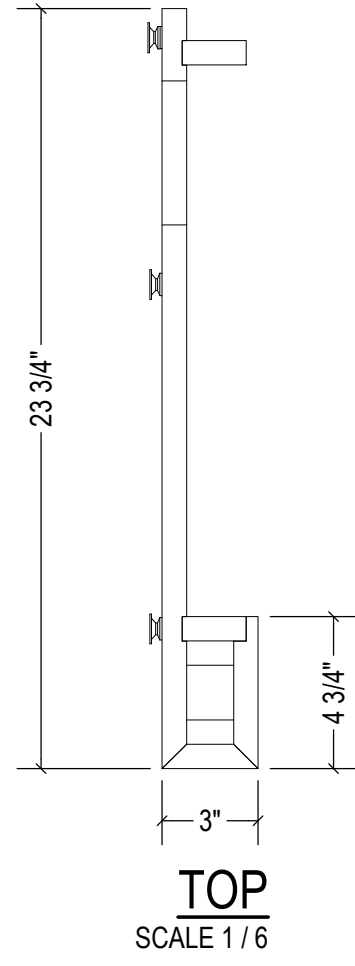

PARTS LIST										
ITEM	QTY	PART NUMBER	C.C.	DESCRIPTION	Length	Width	Thk.	Material	Finish	EB
1	1	3083-003-01	FC	FRENCH CLEAT - WALL	120	5.5	0.76	Medium Density Fiberboard		N/A

DATE:	3/4/2026
DRAWN BY:	BH
FIXTURE NAME:	BB-03
PART #:	3083-BB03-D
JOB #:	3083
SHEET #:	003.9

**16 PIECES REQ'D @ 10 FT LENGTHS  
OR  
13 PIECES REQ'D @ 12 FT LENGTHS**

**SHIPS LOOSE TO SITE**

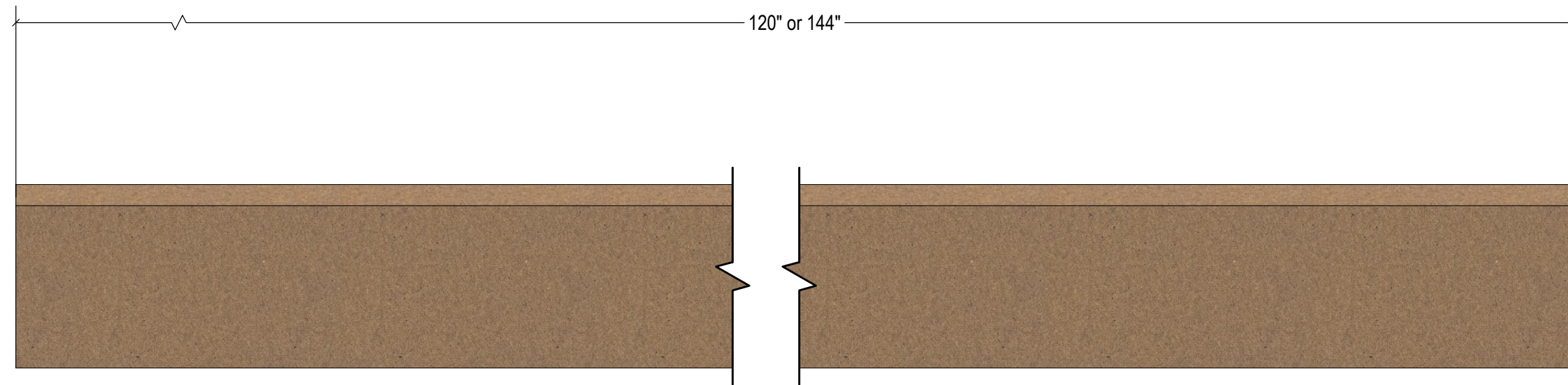

**FRONT**  
SCALE 1/4



**SIDE**  
SCALE 1/4

**NAPLES BEACH BOUTIQUE  
NAPLES, FL**

Description:  
**FRENCH CLEAT - WALL**



3939 WASHINGTON BOULEVARD BALTIMORE, MARYLAND 21227-4165  
PH: (410) 242-0400 FX: (410) 242-0475  
A DIVISION OF WEITZMAN INDUSTRIES, INC.

- REVISIONS -

BY	DATE	REMARKS

THIS DRAWING REMAINS THE PROPERTY OF DISPLAY CRAFT MFG CO. THE INFORMATION CONTAINED HEREON IS FOR THE SPECIFIC USE OF THE INDIVIDUAL PROJECT, AND MAY NOT BE USED FOR ANY OTHER PURPOSE WITHOUT THE WRITTEN CONSENT OF DISPLAY CRAFT MFG. CO.

PARTS LIST										
ITEM	QTY	PART NUMBER	C.C.	DESCRIPTION	Length	Width	Thk.	Material	Finish	EB
1	1	3083-003B-A03	FC	WIDTH SUPPORT	37	5.25	0.76	Medium Density Fiberboard		N/A
2	4	3083-003B-A04	FC	DEPTH SUPPORT	20	5.25	0.76	Medium Density Fiberboard		N/A
3	1	3083-003B-A01	FC	FRONT	41	5.875	0.765	PLYBOO G2S	20% SHEEN CLEAR	N/A
4	1	3083-003B-A02	FC	TOP	41	20.625	0.765	PLYBOO G2S	20% SHEEN CLEAR	N/A
5	4	BUTTON FIX - CLIP	P	BUTTON FIX - CLIP						

DATE:	3/4/2026
DRAWN BY:	BH
FIXTURE NAME:	BB-03
PART #:	3083-BB03B-A
JOB #:	3083
SHEET #:	003.10

NAPLES BEACH BOUTIQUE  
NAPLES, FL

TOE KICK - 41 INCH



3939 WASHINGTON BOULEVARD BALTIMORE, MARYLAND 21227-4165  
PH: (410) 242-0400 FX: (410) 242-0475  
A DIVISION OF WEITZMAN INDUSTRIES, INC.

- REVISIONS -

BY	DATE	REMARKS

THIS DRAWING REMAINS THE PROPERTY OF DISPLAY CRAFT MFG. CO. THE INFORMATION CONTAINED HEREON IS FOR THE SPECIFIC USE OF THE INDIVIDUAL PROJECT, AND MAY NOT BE USED FOR ANY OTHER PURPOSE WITHOUT THE WRITTEN CONSENT OF DISPLAY CRAFT MFG. CO.



ISO  
SCALE 1/8

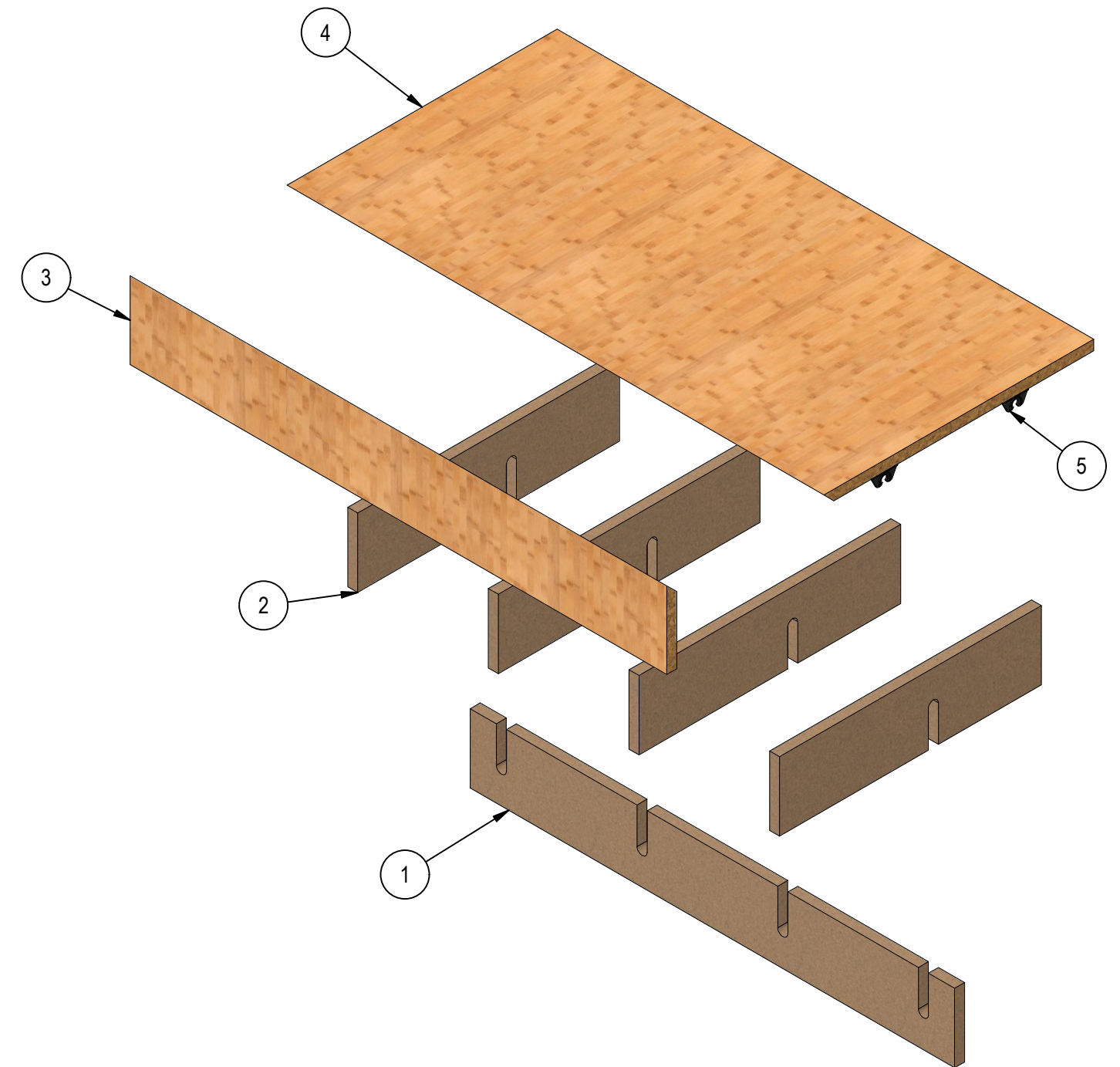

EXPLODED  
SCALE 1/8

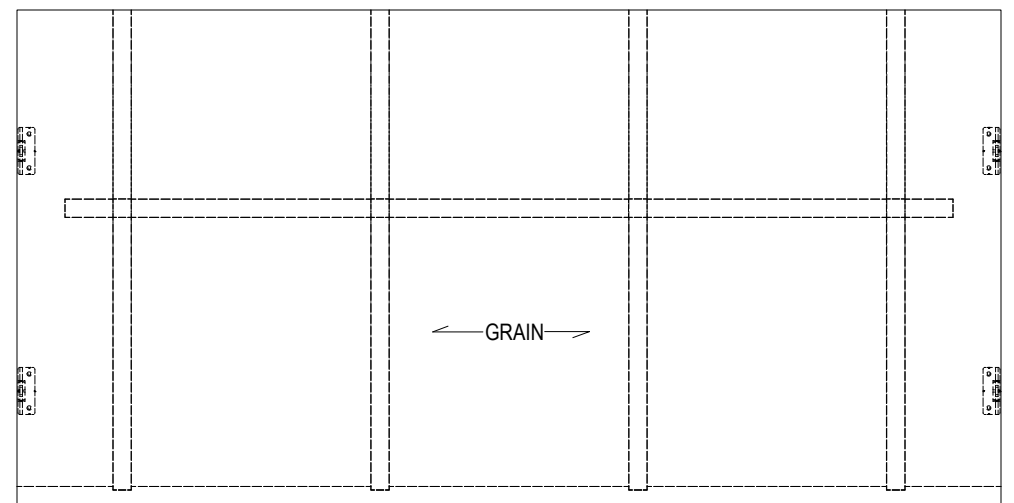

TOP  
SCALE 1/8

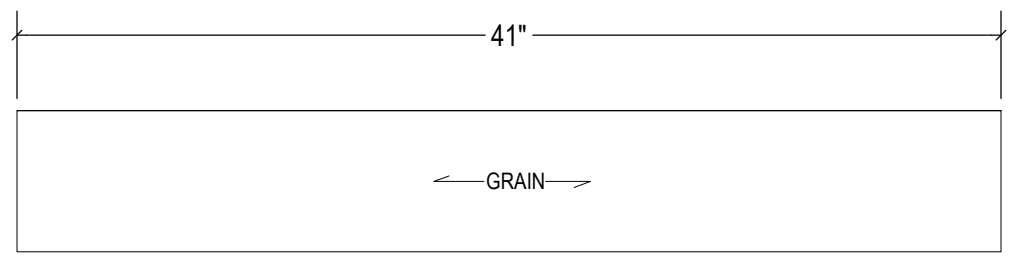

FRONT  
SCALE 1/8

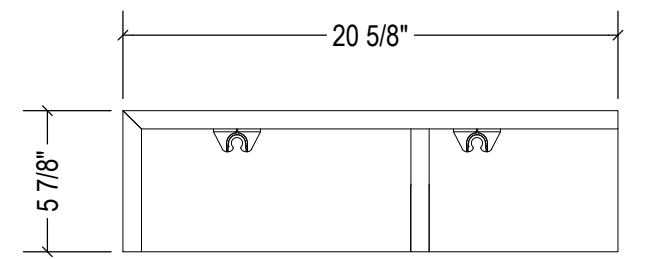

SIDE  
SCALE 1/8





PARTS LIST										
ITEM	QTY	PART NUMBER	C.C.	DESCRIPTION	Length	Width	Thk.	Material	Finish	EB
1	2	3083-003B-D04	FC	DEPTH SUPPORT	19.47	2.125	0.76	Medium Density Fiberboard		N/A
2	1	3083-003B-D01	FC	FRONT	24	3	0.765	PLYBOO G2S	20% SHEEN CLEAR	N/A
3	1	3083-003B-D02	FC	BOTTOM	24	21.485	0.256	PLYBOO G2S	20% SHEEN CLEAR	N/A
4	1	3083-003B-D03	FC	TOP	24	23.75	0.765	PLYBOO G2S	20% SHEEN CLEAR	N/A
5	1	3083-003B-D05	FC	LED RISER	24	2.125	0.765	PLYBOO G2S	20% SHEEN CLEAR	N/A
6	1	3083-003B-D07	FC	LED PANEL	24	1.78	0.765	PLYBOO G2S	20% SHEEN CLEAR	N/A
7	2	3083-003B-D06	FS	WIDTH SUPPORT	19.505	1.985	0.76	Medium Density Fiberboard		N/A
8	4	BUTTON FIX - CLIP	P	BUTTON FIX - CLIP						
9	4	SELF-MC45-AR01	P	SELF-MC45-AR	1.181	0.45	0.429	Steel Profile		N/A

DATE:	3/4/2026
DRAWN BY:	BH
FIXTURE NAME:	BB-03
PART #:	3083-BB03B-D
JOB #:	3083
SHEET #:	003.13

NAPLES BEACH BOUTIQUE  
NAPLES, FL  
MID SHELF - 24 INCH



3939 WASHINGTON BOULEVARD BALTIMORE, MARYLAND 21227-4165  
PH: (410) 242-0400 FX: (410) 242-0475  
A DIVISION OF WEITZMAN INDUSTRIES, INC.

- REVISIONS -

BY	DATE	REMARKS

THIS DRAWING REMAINS THE PROPERTY OF DISPLAY CRAFT MFG. CO. THE INFORMATION CONTAINED HEREON IS FOR THE SPECIFIC USE OF THE INDIVIDUAL PROJECT, AND MAY NOT BE USED FOR ANY OTHER PURPOSE WITHOUT THE WRITTEN CONSENT OF DISPLAY CRAFT MFG. CO.



ISO  
SCALE 1/6

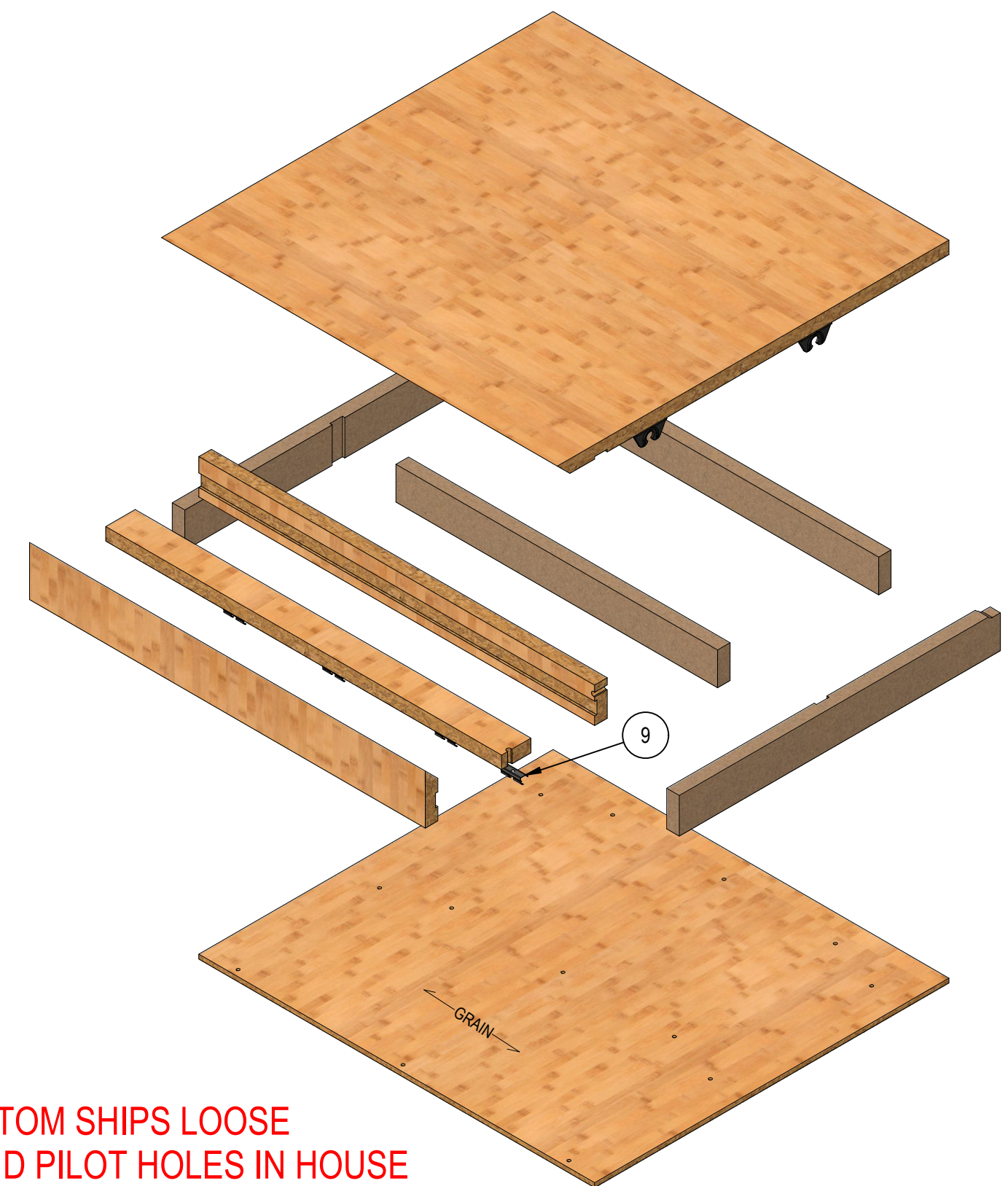

EXPLODED  
SCALE 1/6

BOTTOM SHIPS LOOSE  
TEST FIT AND PILOT HOLES IN HOUSE

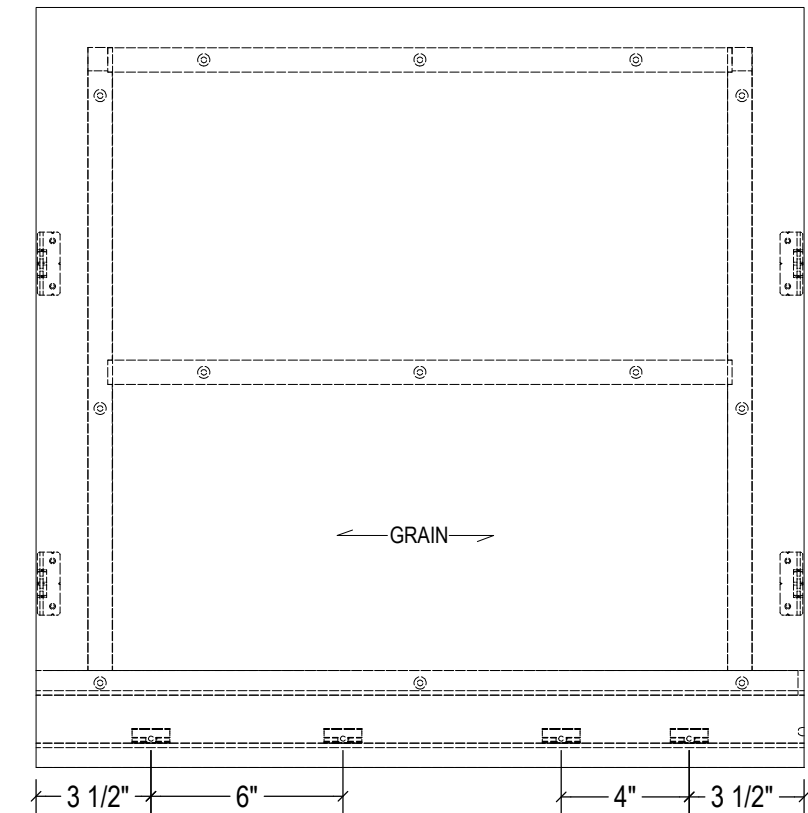

TOP  
SCALE 1/6

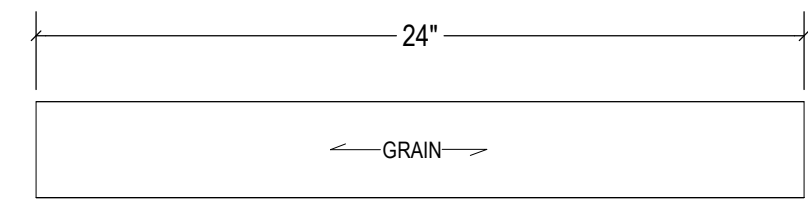

FRONT  
SCALE 1/6

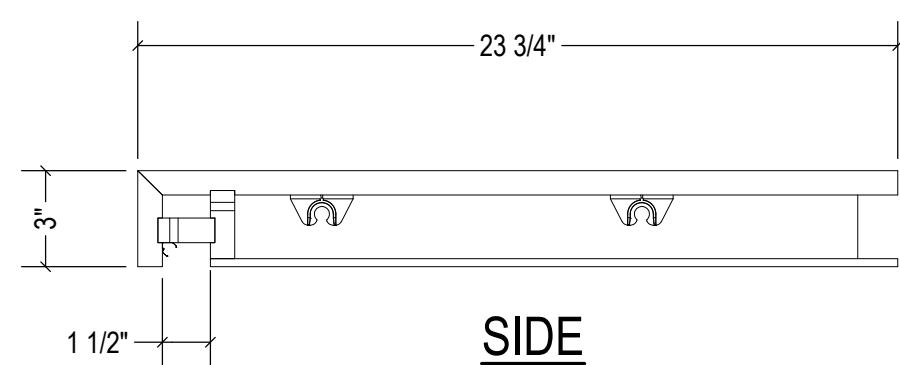

SIDE  
SCALE 1/6









PARTS LIST										
ITEM	QTY	PART NUMBER	C.C.	DESCRIPTION	Length	Width	Thk.	Material	Finish	EB
4	2	3083-003B-G04	FC	STIFFENER	41	2.125	0.765	Medium Density Fiberboard		N/A
1	1	3083-003B-G01	FC	FRONT	41	3	0.765	PLYBOO G2S	20% SHEEN CLEAR	1L
2	1	3083-003B-G02	FC	LED MOUNT	41	2.375	0.765	PLYBOO G2S	20% SHEEN CLEAR	N/A
3	1	3083-003B-G03	FC	BASE	41	19.985	0.765	PLYBOO G2S	20% SHEEN CLEAR	1L
5	4	BUTTON FIX - CLIP	P	BUTTON FIX - CLIP						
6	6	SELF-MC45-AR01	P	SELF-MC45-AR	1.181	0.45	0.429	Steel Profile		N/A

DATE:	3/4/2026
DRAWN BY:	BH
FIXTURE NAME:	BB-03
PART #:	3083-BB03B-G
JOB #:	3083
SHEET #:	003.18

NAPLES BEACH BOUTIQUE  
NAPLES, FL

TOP SHELF - 41 INCH

Description:



3939 WASHINGTON BOULEVARD BALTIMORE, MARYLAND 21227-4165  
PH: (410) 242-0400 FX: (410) 242-0475  
A DIVISION OF WEITZMAN INDUSTRIES, INC.

- REVISIONS -

BY	DATE	REMARKS

THIS DRAWING REMAINS THE PROPERTY OF DISPLAY CRAFT MFG CO. THE INFORMATION CONTAINED HEREON IS FOR THE SPECIFIC USE OF THE INDIVIDUAL PROJECT, AND MAY NOT BE USED FOR ANY OTHER PURPOSE WITHOUT THE WRITTEN CONSENT OF DISPLAY CRAFT MFG. CO.

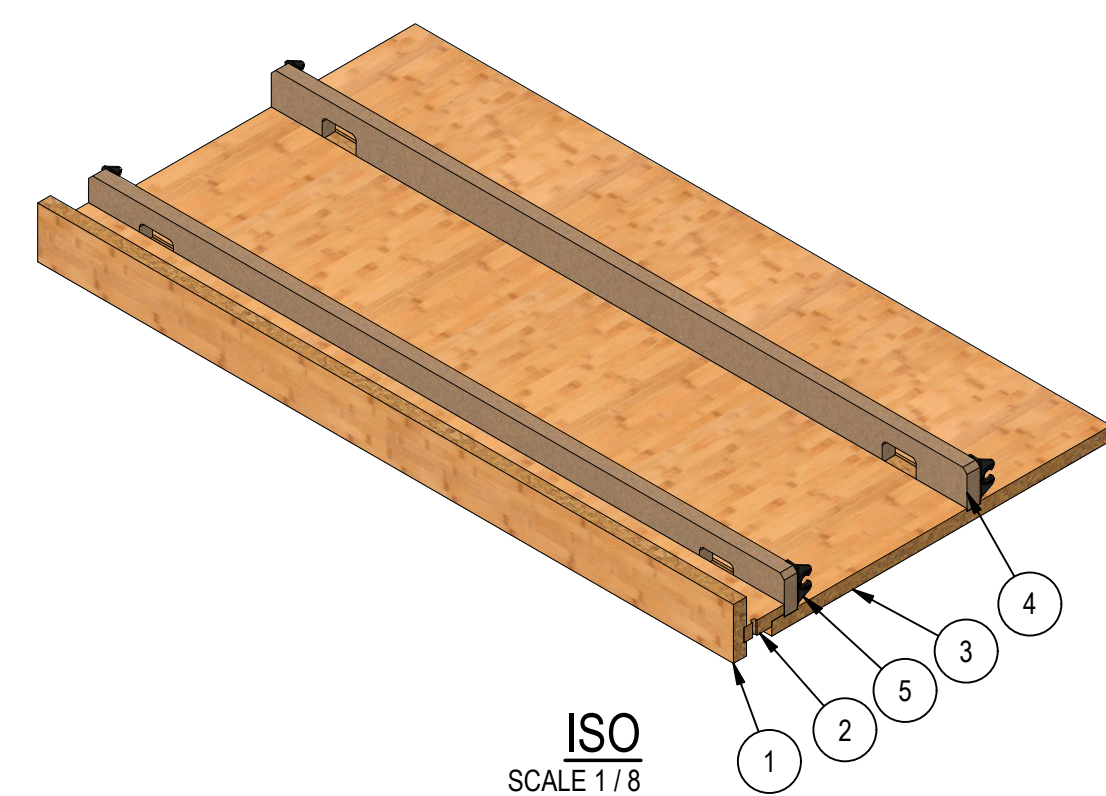

ISO  
SCALE 1/8

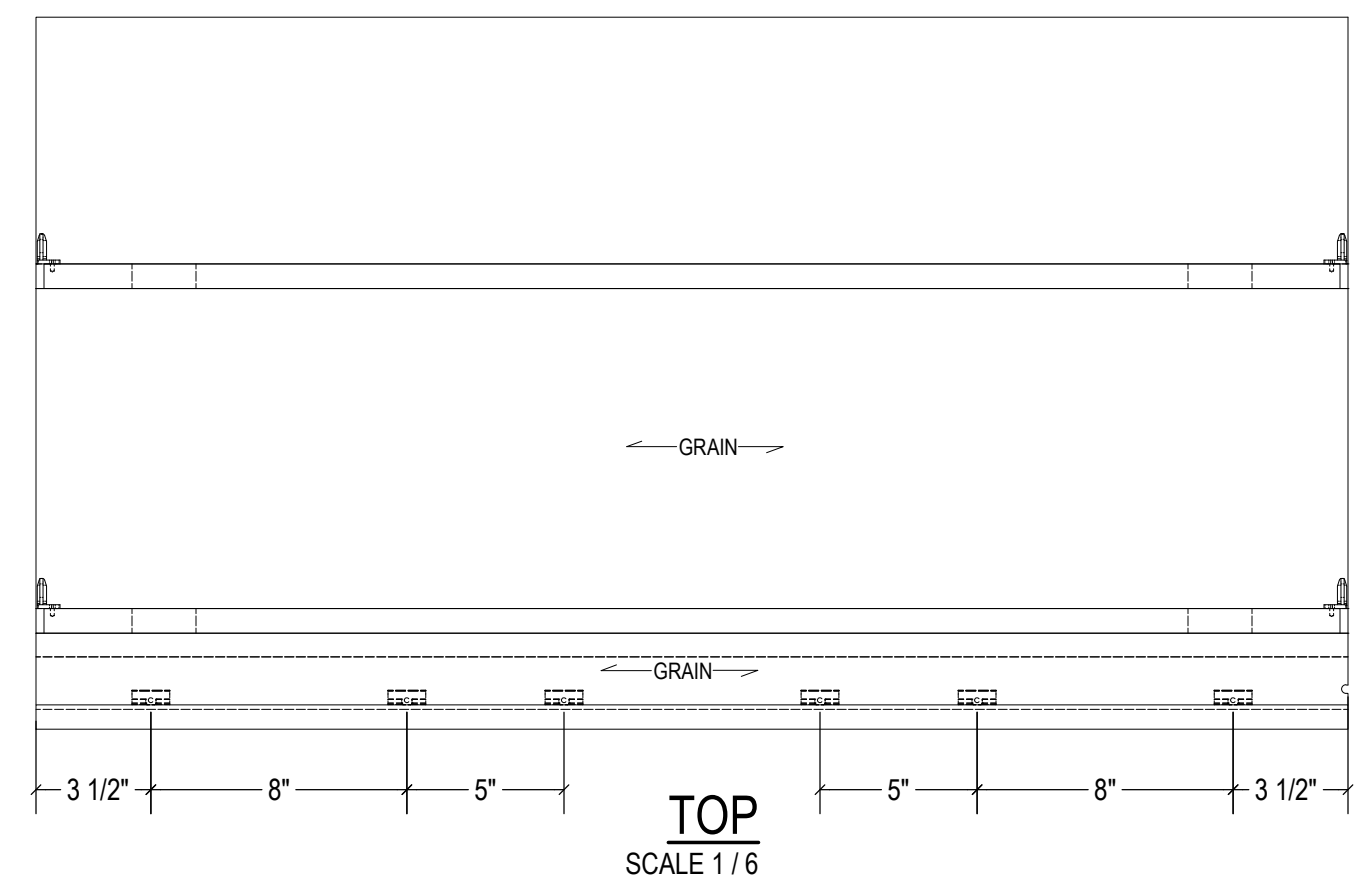

TOP  
SCALE 1/6

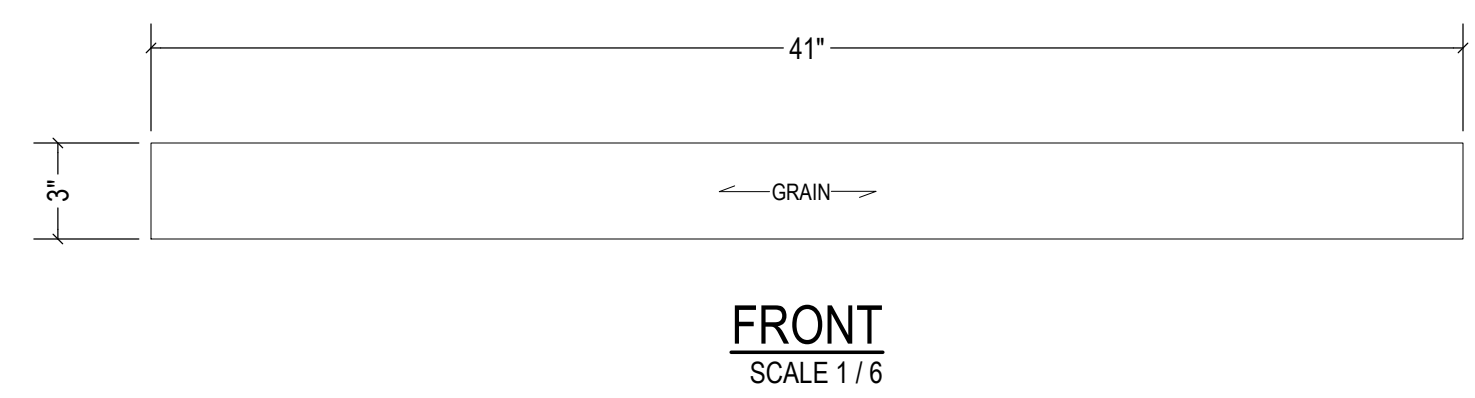

FRONT  
SCALE 1/6

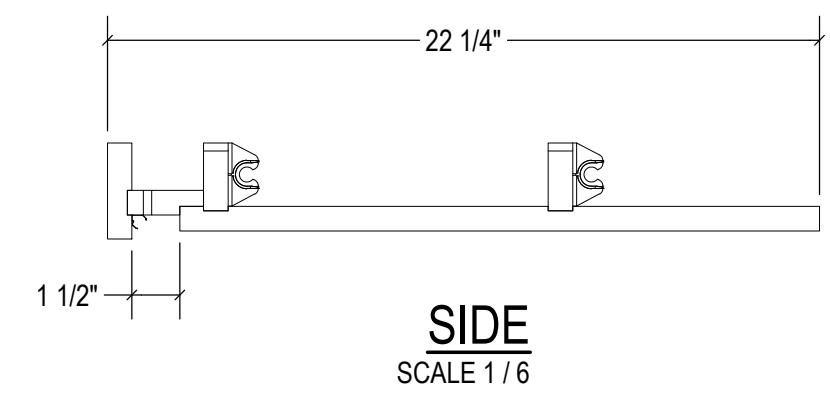

SIDE  
SCALE 1/6

PARTS LIST										
ITEM	QTY	PART NUMBER	C.C.	DESCRIPTION	Length	Width	Thk.	Material	Finish	EB
1	2	3083-003B-H04		STIFFENER	24	2.125	0.765	Medium Density Fiberboard		N/A
2	1	3083-003B-H01	FC	FRONT	24	3	0.765	PLYBOO G2S	20 SHEEN CLEAR	1L
3	1	3083-003B-H02	FC	LED MOUNT	24	2.375	0.765	PLYBOO G2S	20 SHEEN CLEAR	N/A
4	1	3083-003B-H03	FC	BASE	24	19.985	0.765	PLYBOO G2S	20 SHEEN CLEAR	1L
5	4	BUTTON FIX - CLIP	P	BUTTON FIX - CLIP						
6	4	SELF-MC45-AR01	P	SELF-MC45-AR	1.181	0.45	0.429	Steel Profile		N/A

DATE:	3/4/2026
DRAWN BY:	BH
FIXTURE NAME:	BB-03
PART #:	3083-BB03B-H
JOB #:	3083
SHEET #:	003.19

NAPLES BEACH BOUTIQUE  
NAPLES, FL

TOP SHELF - 24 INCH

Description:



3939 WASHINGTON BOULEVARD BALTIMORE, MARYLAND 21227-4165  
PH: (410) 242-0400 FX: (410) 242-0475  
A DIVISION OF WEITZMAN INDUSTRIES, INC.

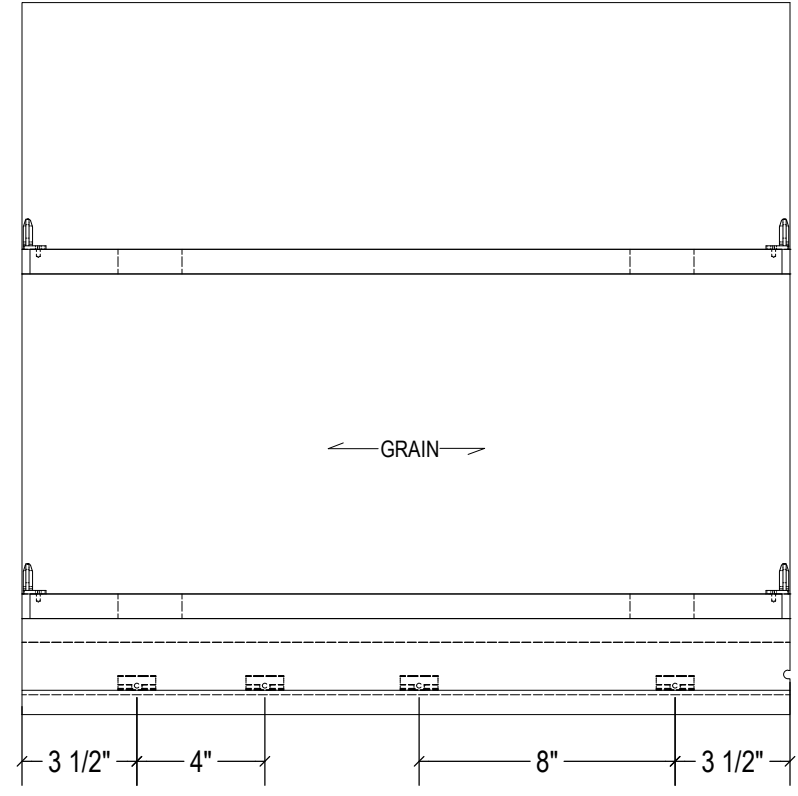

TOP  
SCALE 1/6

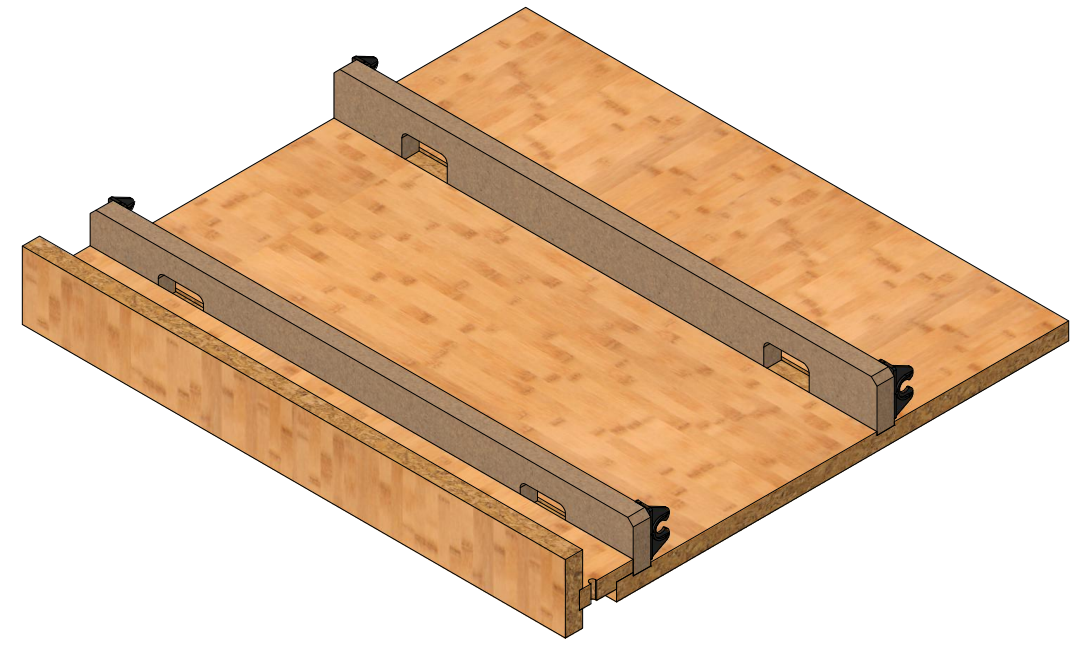

ISO  
SCALE 1/6

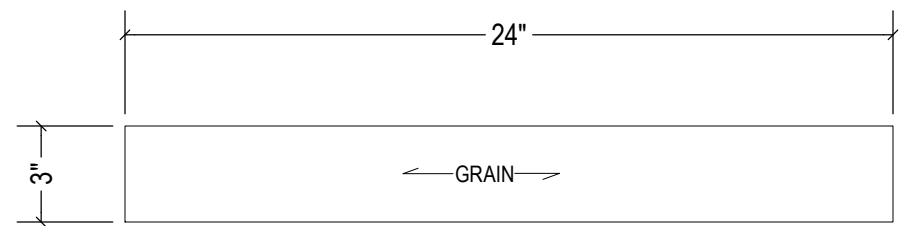

FRONT  
SCALE 1/6

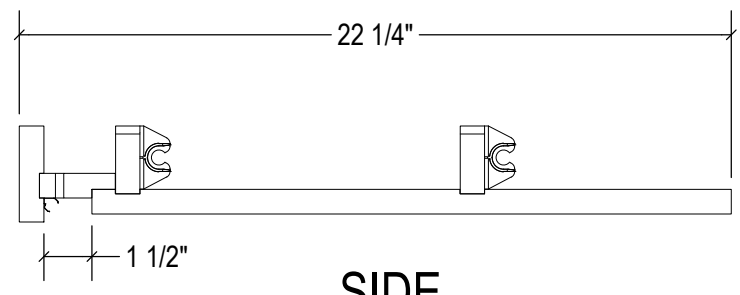

SIDE  
SCALE 1/6

- REVISIONS -

BY	DATE	REMARKS

THIS DRAWING REMAINS THE PROPERTY OF DISPLAY CRAFT MFG. CO. THE INFORMATION CONTAINED HEREON IS FOR THE SPECIFIC USE OF THE INDIVIDUAL PROJECT, AND MAY NOT BE USED FOR ANY OTHER PURPOSE WITHOUT THE WRITTEN CONSENT OF DISPLAY CRAFT MFG. CO.

PARTS LIST										
ITEM	QTY	PART NUMBER	C.C.	DESCRIPTION	Length	Width	Thk.	Material	Finish	EB
1	2	3083-003B-J07	FC	REAR STILE	26.125	1.485	0.76	Medium Density Fiberboard		N/A
2	2	3083-003B-J02	FC	INNER RAIL	36.375	1.5	0.765	PLYBOO G2S	20% SHEEN CLEAR	N/A
3	1	3083-003B-J04	FC	LEFT STILE	26.125	1.5	0.765	PLYBOO G2S	20% SHEEN CLEAR	N/A
4	1	3083-003B-J06	FC	RIGHT STILE	26.125	1.5	0.765	PLYBOO G2S	20% SHEEN CLEAR	N/A
5	12	3083-003B-J05	FM	SLATS	37.375	2.131	0.256	PLYBOO G2S	20% SHEEN CLEAR	N/A
6	2	3083-003B-J01	FS	FRONT STILE	26.125	1.625	0.76	Medium Density Fiberboard		N/A
7	2	3083-003B-J03	FS	OUTER RAIL	36.375	1.625	0.76	Medium Density Fiberboard		N/A
8	2	3083-003B-JV01	FS	STILE VENEER	26.125	2.25	0.023	PLYBOO G2S	20% SHEEN CLEAR	N/A
9	2	3083-003B-JV02	FS	RAIL VENEER	36.375	2.25	0.023	PLYBOO G2S	20% SHEEN CLEAR	N/A
10	4	BUTTON FIX - CLIP	P	BUTTON FIX - CLIP						

DATE: 3/4/2026  
 DRAWN BY: BH  
 FIXTURE NAME: BB-03  
 PART #: 3083-BB03B-J  
 JOB #: 3083  
 SHEET #: 003.20

NAPLES BEACH BOUTIQUE  
 NAPLES, FL  
 LOUVER - 41 INCH

Description:



3959 WASHINGTON BOULEVARD BALTIMORE, MARYLAND 21227-4165  
 PH: (410) 242-0400 FX: (410) 242-0475  
 A DIVISION OF WEITZMAN INDUSTRIES, INC.

- REVISIONS -

BY	DATE	REMARKS

THIS DRAWING REMAINS THE PROPERTY OF DISPLAY CRAFT MFG. CO. THE INFORMATION CONTAINED HEREON IS FOR THE SPECIFIC USE OF THE INDIVIDUAL PROJECT, AND MAY NOT BE USED FOR ANY OTHER PURPOSE WITHOUT THE WRITTEN CONSENT OF DISPLAY CRAFT MFG. CO.

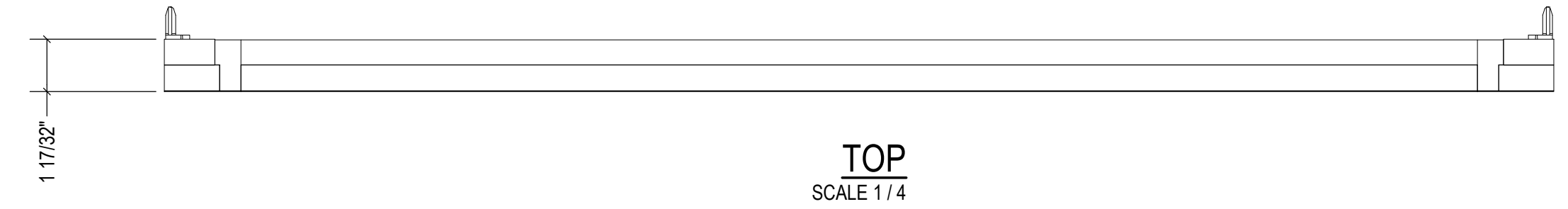

TOP  
SCALE 1/4

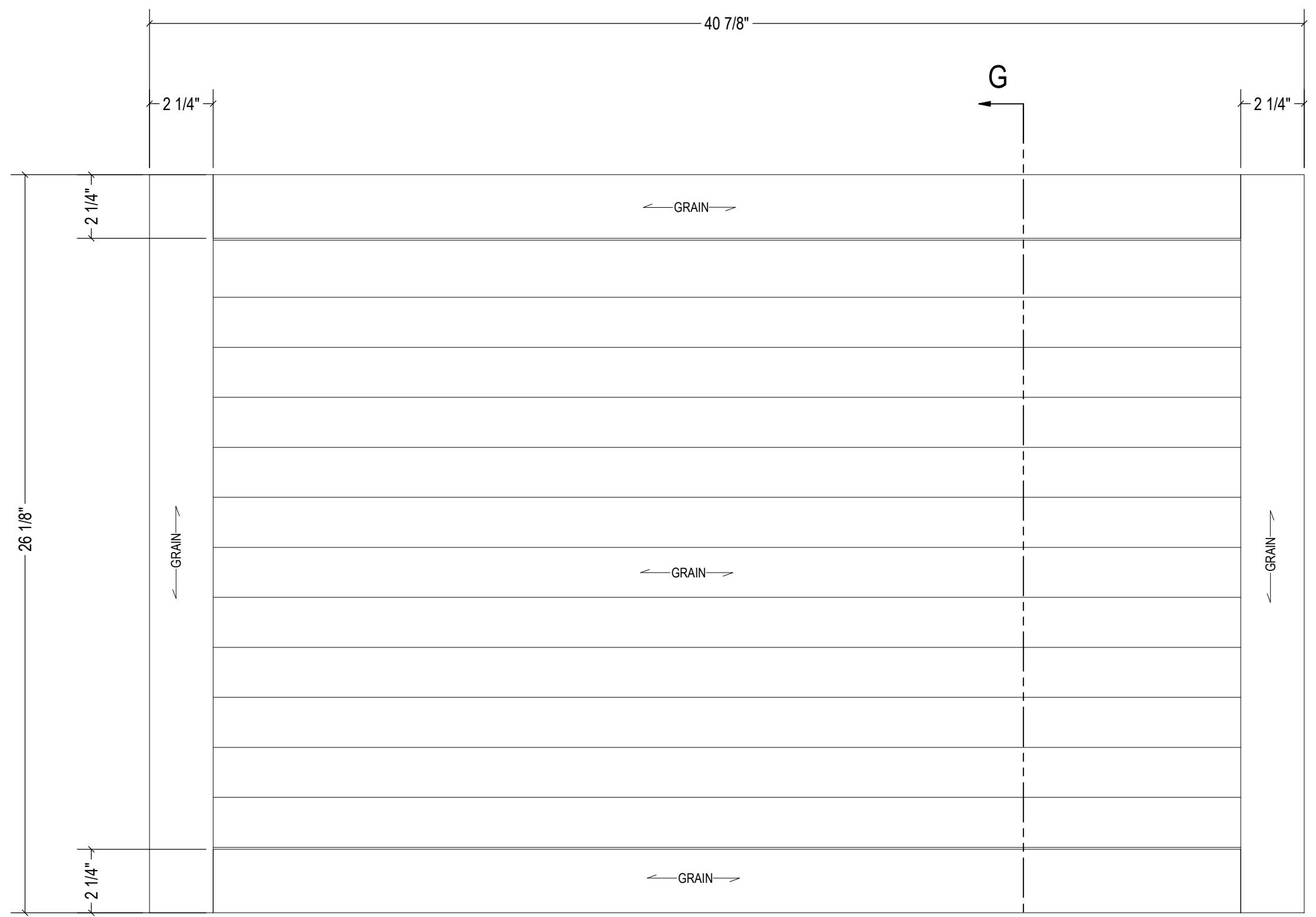

FRONT  
SCALE 1/4

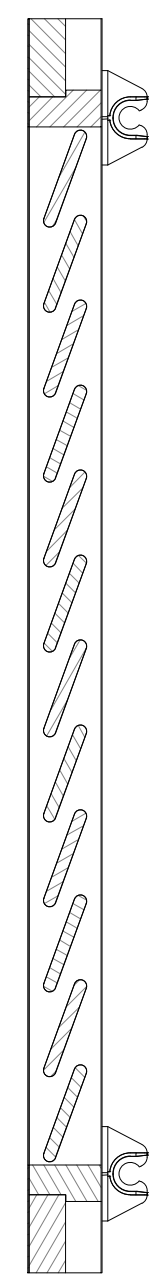

SECTION G  
SCALE 1/4

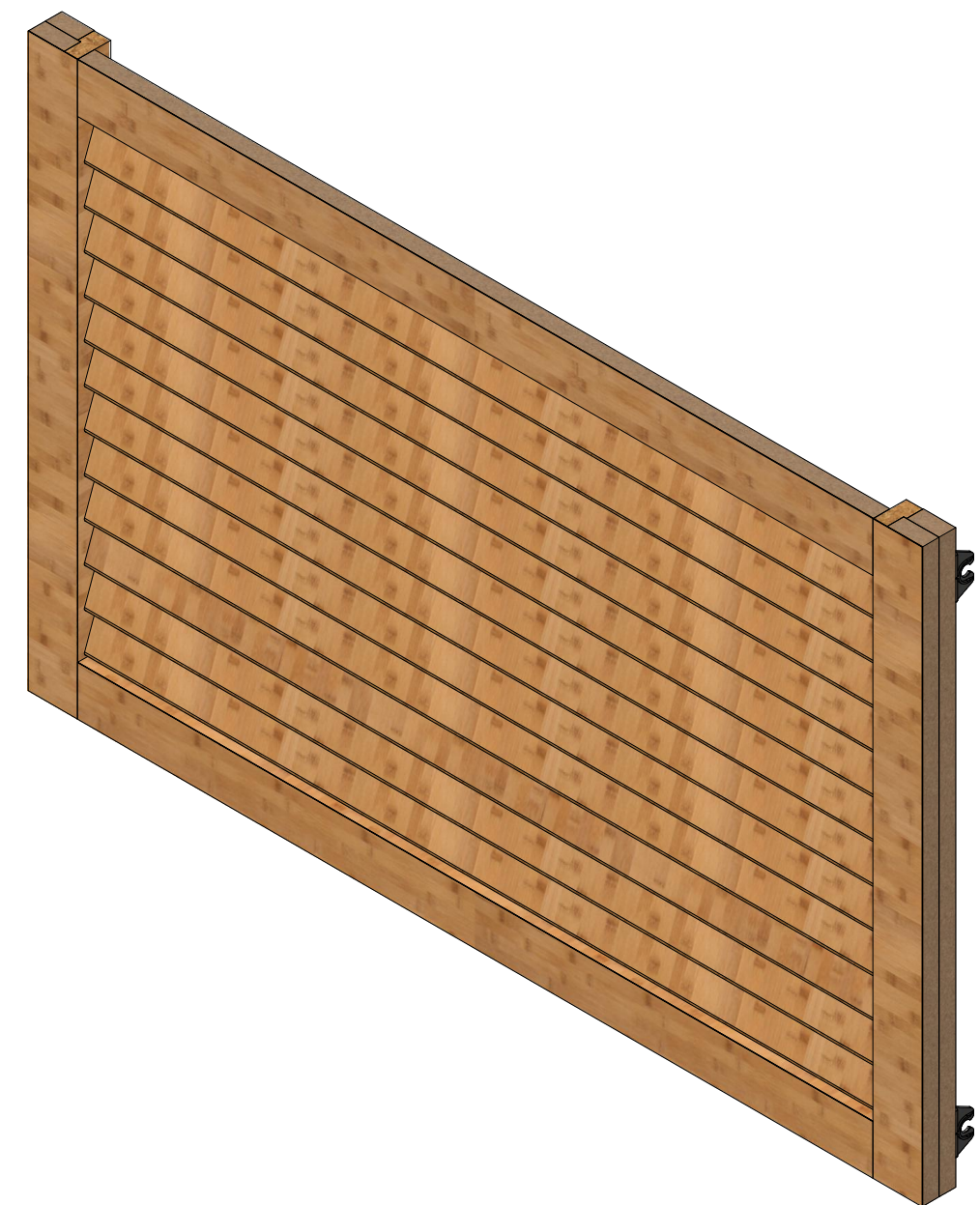

ISO  
SCALE 1/6



PARTS LIST										
ITEM	QTY	PART NUMBER	C.C.	DESCRIPTION	Length	Width	Thk.	Material	Finish	EB
1	2	3083-003B-K07	FC	REAR STILE	26.125	1.485	0.76	Medium Density Fiberboard		N/A
2	2	3083-003B-K01	FC	INNER RAIL	19.375	1.5	0.765	PLYBOO G2S	20% SHEEN CLEAR	N/A
3	1	3083-003B-K02	FC	LEFT STILE	26.125	1.5	0.765	PLYBOO G2S	20% SHEEN CLEAR	N/A
4	1	3083-003B-K04	FC	RIGHT STILE	26.125	1.5	0.765	PLYBOO G2S	20% SHEEN CLEAR	N/A
5	12	3083-003B-K03	FM	SLATS	20.375	2.131	0.256	PLYBOO G2S	20% SHEEN CLEAR	N/A
6	2	3083-003B-K05	FS	FRONT STILE	26.125	1.625	0.76	Medium Density Fiberboard		N/A
7	2	3083-003B-K06	FS	OUTER RAIL	19.375	1.625	0.76	Medium Density Fiberboard		N/A
8	2	3083-003B-KV01	FS	STILE VENEER	26.125	2.25	0.023	PLYBOO G2S	20% SHEEN CLEAR	N/A
9	2	3083-003B-KV02	FS	RAIL VENEER	19.375	2.25	0.023	PLYBOO G2S	20% SHEEN CLEAR	N/A
10	4	BUTTON FIX - CLIP	P	BUTTON FIX - CLIP						

DATE: 3/4/2026  
 DRAWN BY: BH  
 FIXTURE NAME: BB-03  
 PART #: 3083-BB03B-K  
 JOB #: 3083  
 SHEET #: 003.22

NAPLES BEACH BOUTIQUE  
 NAPLES, FL  
 LOUVER - 24 INCH



3939 WASHINGTON BOULEVARD BALTIMORE, MARYLAND 21227-4165  
 PH: (410) 242-0400 FX: (410) 242-0475  
 A DIVISION OF WEITZMAN INDUSTRIES, INC.

- REVISIONS -

BY	DATE	REMARKS

THIS DRAWING REMAINS THE PROPERTY OF DISPLAY CRAFT MFG. CO. THE INFORMATION CONTAINED HEREON IS FOR THE SPECIFIC USE OF THE INDIVIDUAL PROJECT, AND MAY NOT BE USED FOR ANY OTHER PURPOSE WITHOUT THE WRITTEN CONSENT OF DISPLAY CRAFT MFG. CO.

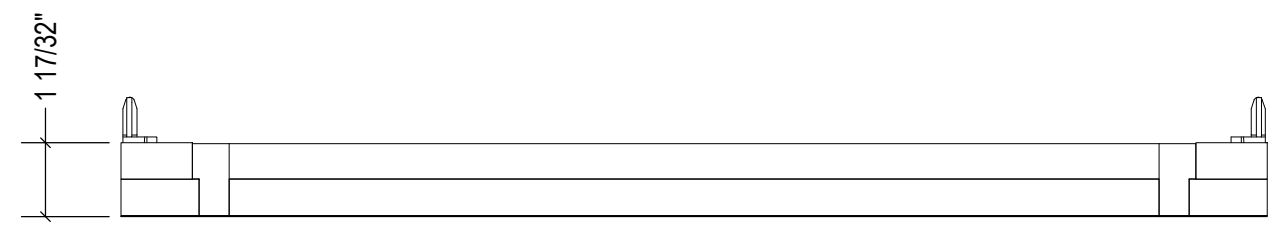

VIEW90  
 SCALE 1 / 4

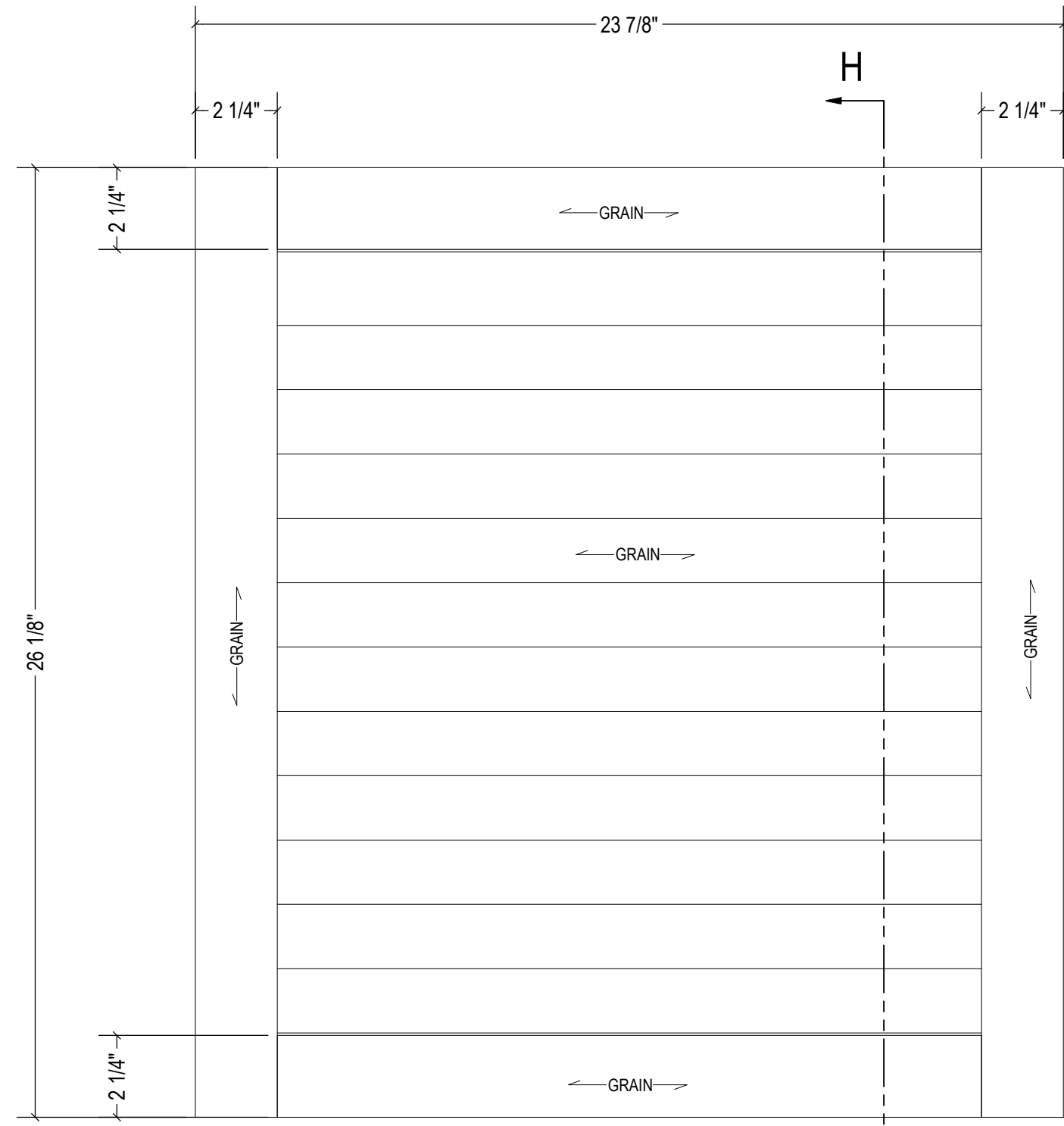

FRONT  
 SCALE 1 / 4

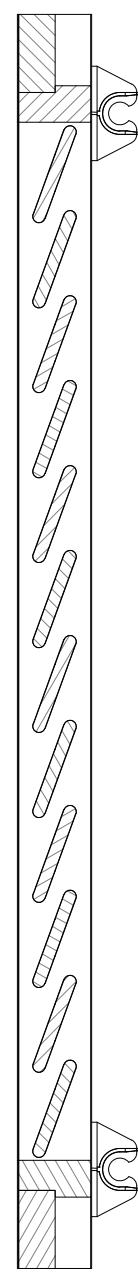

SECTION H  
 SCALE 1 / 4



ISO  
 SCALE 1 / 4



PARTS LIST										
ITEM	QTY	PART NUMBER	C.C.	DESCRIPTION	Length	Width	Thk.	Material	Finish	EB
1	1	3083-003B-LA01	FC	BACK PANEL	67.875	40.969	0.76	Medium Density Fiberboard		N/A
2	2	3083-003B-LB01	FC	CLEAT	40	5.5	0.76	Medium Density Fiberboard		N/A
3	2	SELF_ELEC-STD	P	STANDARD				ALUMINUM		

DATE:	3/4/2026
DRAWN BY:	BH
FIXTURE NAME:	BB-03
PART #:	3083-BB03B-L
JOB #:	3083
SHEET #:	003.24

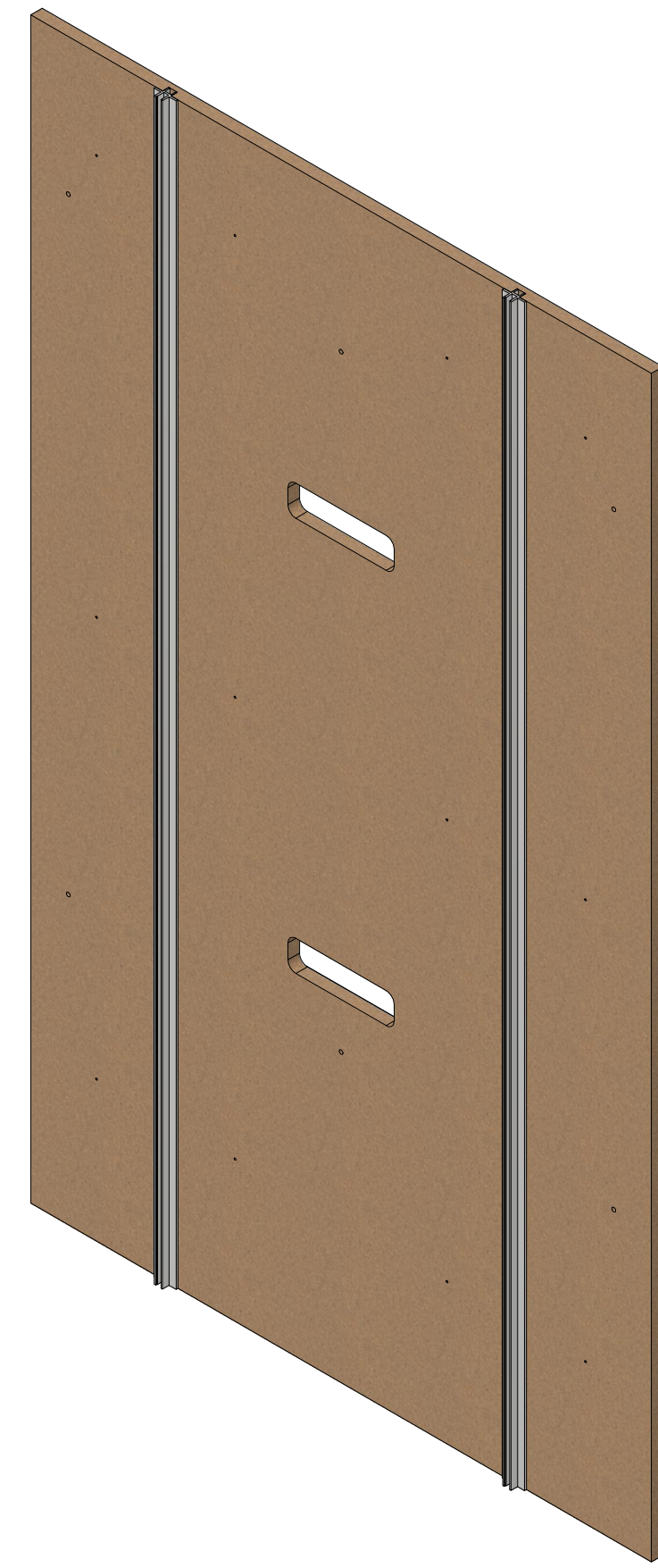
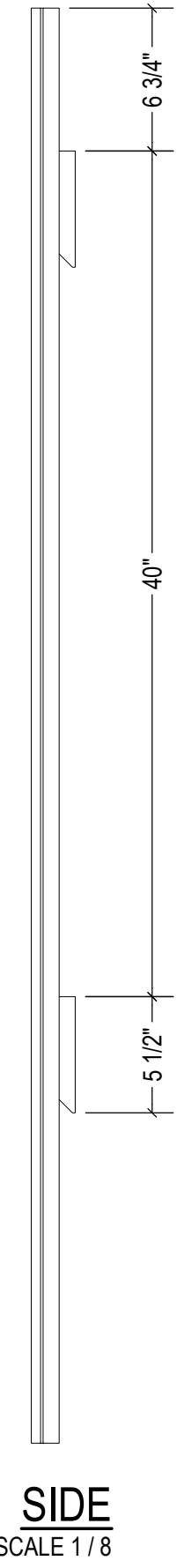
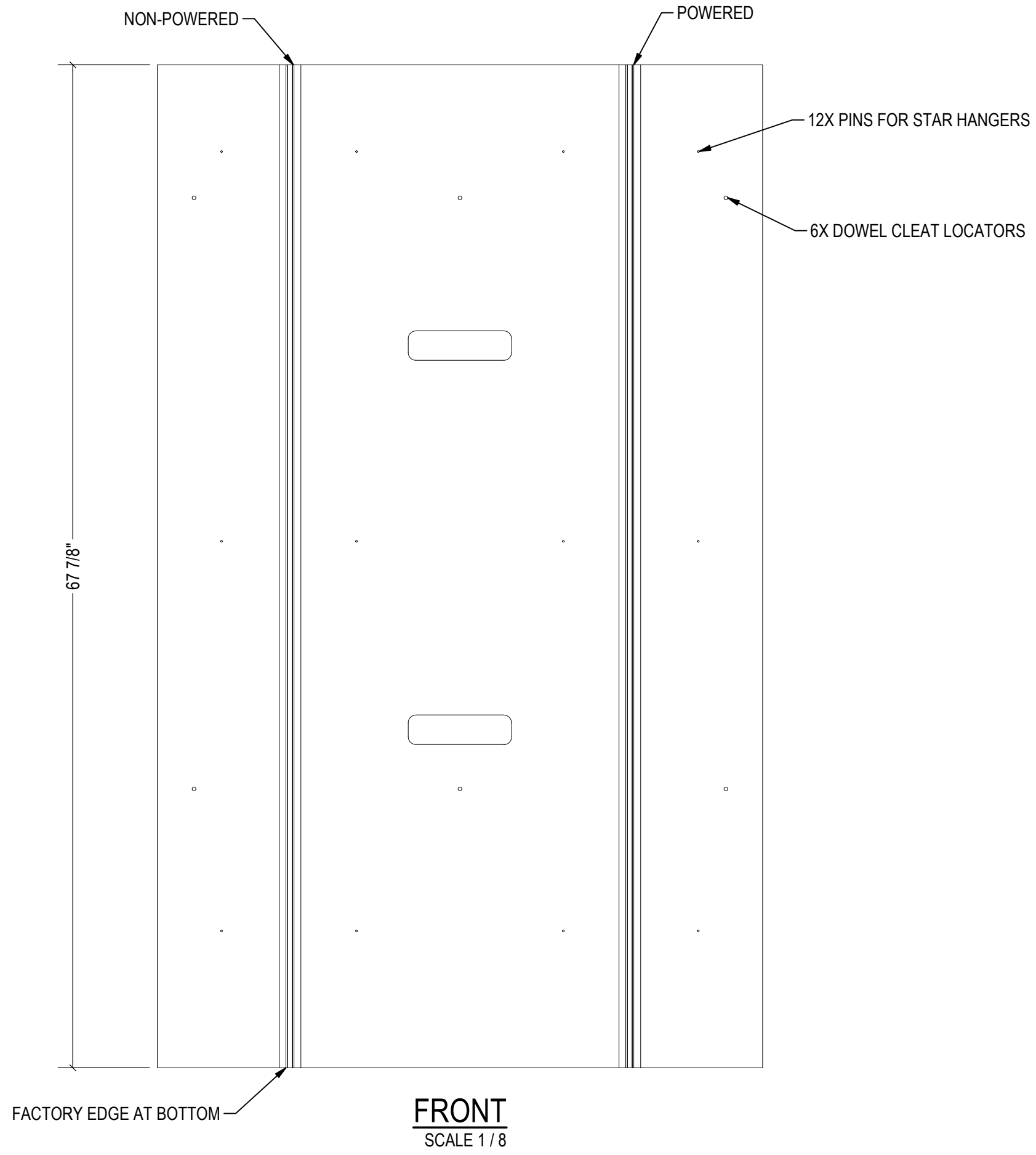
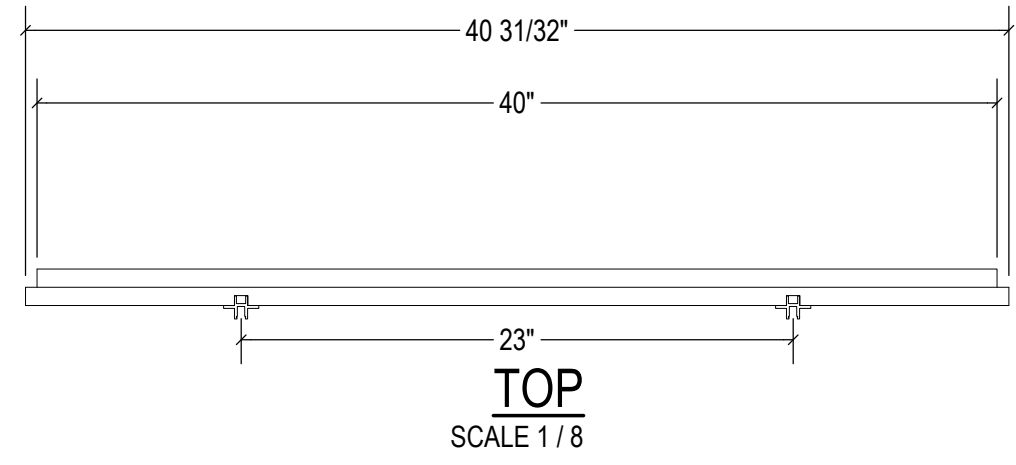

NAPLES BEACH BOUTIQUE  
NAPLES, FL

BACK PANEL ASSEMBLY - 41 INCH



3959 WASHINGTON BOULEVARD BALTIMORE, MARYLAND 21227-4165  
PH: (410) 242-0400 FX: (410) 242-0475  
A DIVISION OF WEITZMAN INDUSTRIES, INC.

- REVISIONS -

BY	DATE	REMARKS

THIS DRAWING REMAINS THE PROPERTY OF DISPLAY CRAFT MFG CO. THE INFORMATION CONTAINED HEREON IS FOR THE SPECIFIC USE OF THE INDIVIDUAL PROJECT, AND MAY NOT BE USED FOR ANY OTHER PURPOSE WITHOUT THE WRITTEN CONSENT OF DISPLAY CRAFT MFG. CO.

PARTS LIST										
ITEM	QTY	PART NUMBER	C.C.	DESCRIPTION	Length	Width	Thk.	Material	Finish	EB
1	1	3083-003B-LA01	FC	BACK PANEL	67.875	40.969	0.76	Medium Density Fiberboard		N/A
2	2	3083-003B-LB01	FC	CLEAT	40	5.5	0.76	Medium Density Fiberboard		N/A
3	2	SELF_ELEC-STD	P	STANDARD				ALUMINUM		

DATE:	3/4/2026
DRAWN BY:	BH
FIXTURE NAME:	BB-03
PART #:	3083-BB03B-L
JOB #:	3083
SHEET #:	003.25

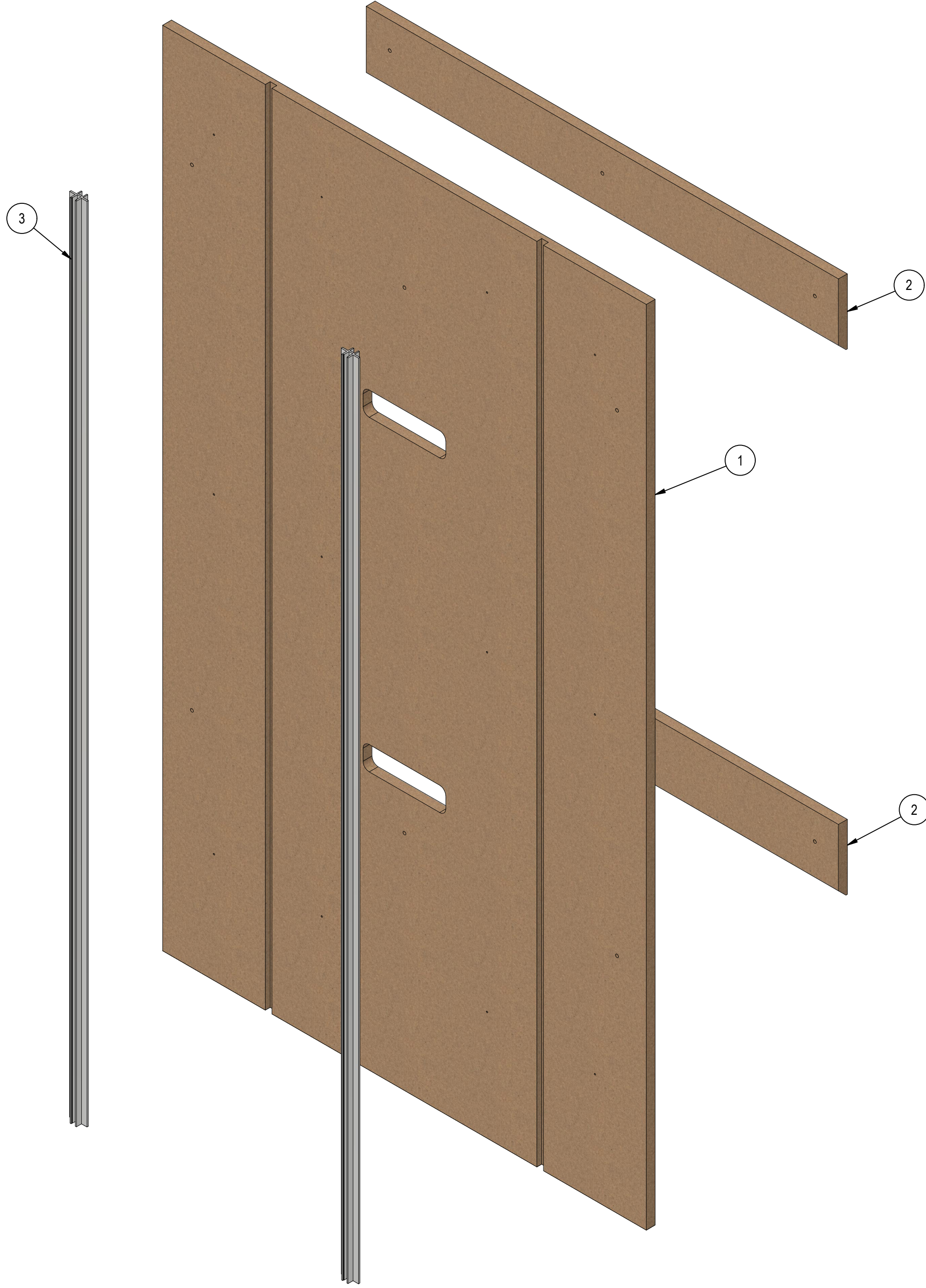

ISO  
SCALE 1 / 5.5

NAPLES BEACH BOUTIQUE  
NAPLES, FL

Description:  
BACK PANEL ASSEMBLY - 41 INCH



3939 WASHINGTON BOULEVARD BALTIMORE, MARYLAND 21227-4165  
PH: (410) 242-0400 FX: (410) 242-0475  
A DIVISION OF WEITZMAN INDUSTRIES, INC.

- REVISIONS -

BY	DATE	REMARKS

THIS DRAWING REMAINS THE PROPERTY OF DISPLAY CRAFT MFG CO. THE INFORMATION CONTAINED HEREON IS FOR THE SPECIFIC USE OF THE INDIVIDUAL PROJECT, AND MAY NOT BE USED FOR ANY OTHER PURPOSE WITHOUT THE WRITTEN CONSENT OF DISPLAY CRAFT MFG. CO.

PARTS LIST										
ITEM	QTY	PART NUMBER	C.C.	DESCRIPTION	Length	Width	Thk.	Material	Finish	EB
1	1	3083-003B-MA01	FC	BACK PANEL	67.875	23.969	0.76	Medium Density Fiberboard		N/A
2	2	3083-003B-MB01	FC	CLEAT	23	5.5	0.76	Medium Density Fiberboard		N/A
3	2	3083-003-PURCH-01	P	STANDARDS	67.875	1.469	0.953	Aluminum Profile		N/A

DATE:	3/4/2026
DRAWN BY:	BH
FIXTURE NAME:	BB-03
PART #:	3083-BB03B-M
JOB #:	3083
SHEET #:	003.26

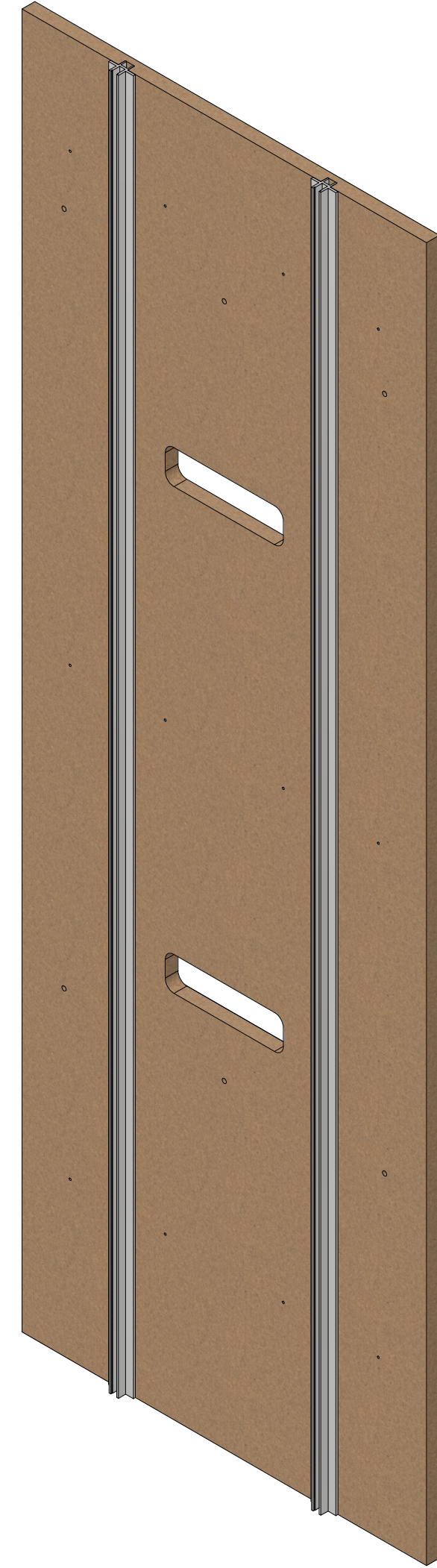
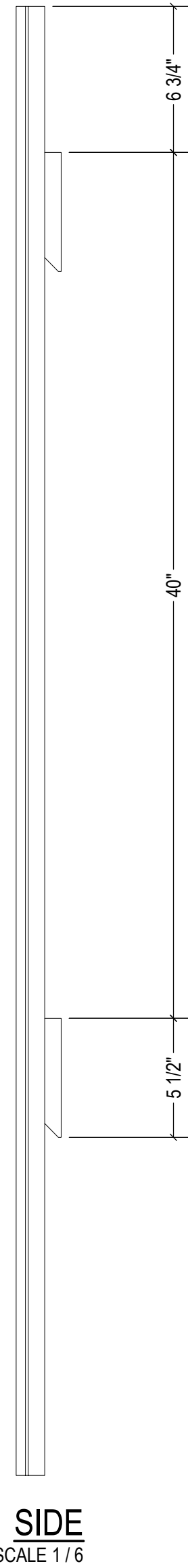
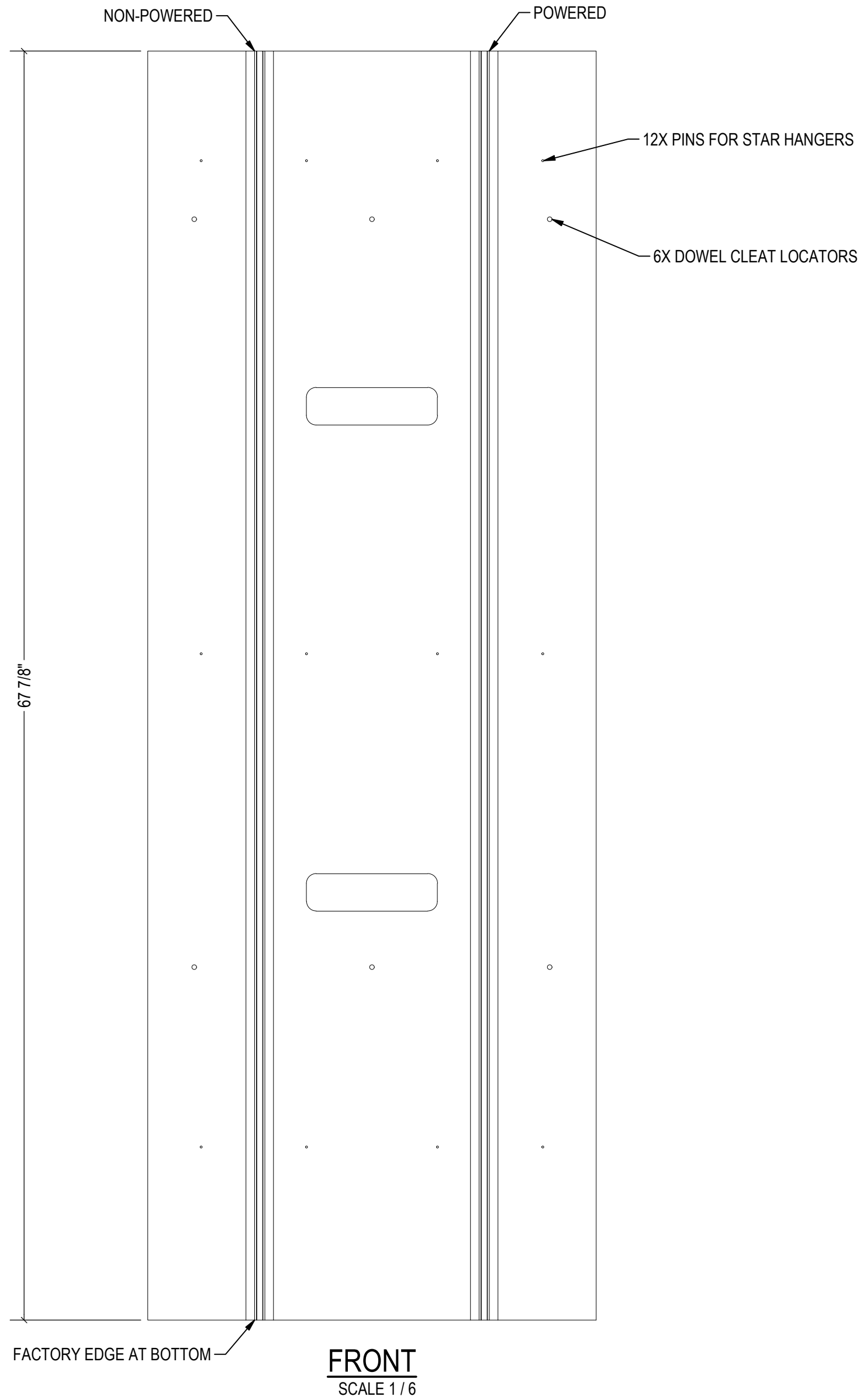
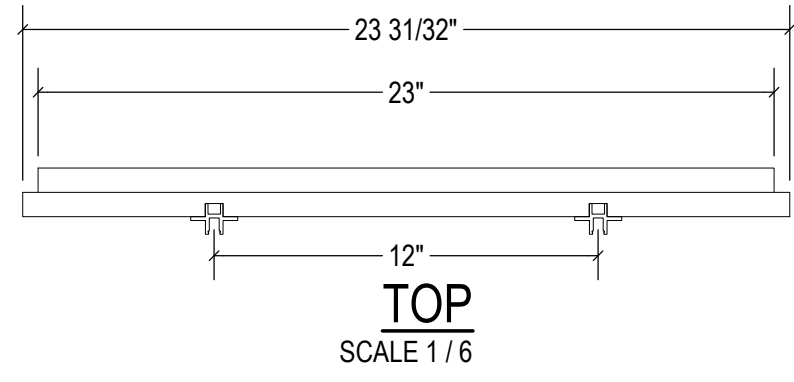

**ISO**  
SCALE 1/6

**NAPLES BEACH BOUTIQUE  
NAPLES, FL**

Description:  
**BACK PANEL ASSEMBLY - 24 INCH**



3939 WASHINGTON BOULEVARD BALTIMORE, MARYLAND 21227-4165  
PH: (410) 242-0400 FX: (410) 242-0475  
A DIVISION OF WEITZMAN INDUSTRIES, INC.

- REVISIONS -

BY	DATE	REMARKS

THIS DRAWING REMAINS THE PROPERTY OF DISPLAY CRAFT MFG. CO. THE INFORMATION CONTAINED HEREON IS FOR THE SPECIFIC USE OF THE INDIVIDUAL PROJECT, AND MAY NOT BE USED FOR ANY OTHER PURPOSE WITHOUT THE WRITTEN CONSENT OF DISPLAY CRAFT MFG. CO.

PARTS LIST										
ITEM	QTY	PART NUMBER	C.C.	DESCRIPTION	Length	Width	Thk.	Material	Finish	EB
1	1	3083-003B-MA01	FC	BACK PANEL	67.875	23.969	0.76	Medium Density Fiberboard		N/A
2	2	3083-003B-MB01	FC	CLEAT	23	5.5	0.76	Medium Density Fiberboard		N/A
3	2	3083-003-PURCH-01	P	STANDARDS	67.875	1.469	0.953	Aluminum Profile		N/A

DATE:	3/4/2026
DRAWN BY:	BH
FIXTURE NAME:	BB-03
PART #:	3083-BB03B-M
JOB #:	3083
SHEET #:	003.27

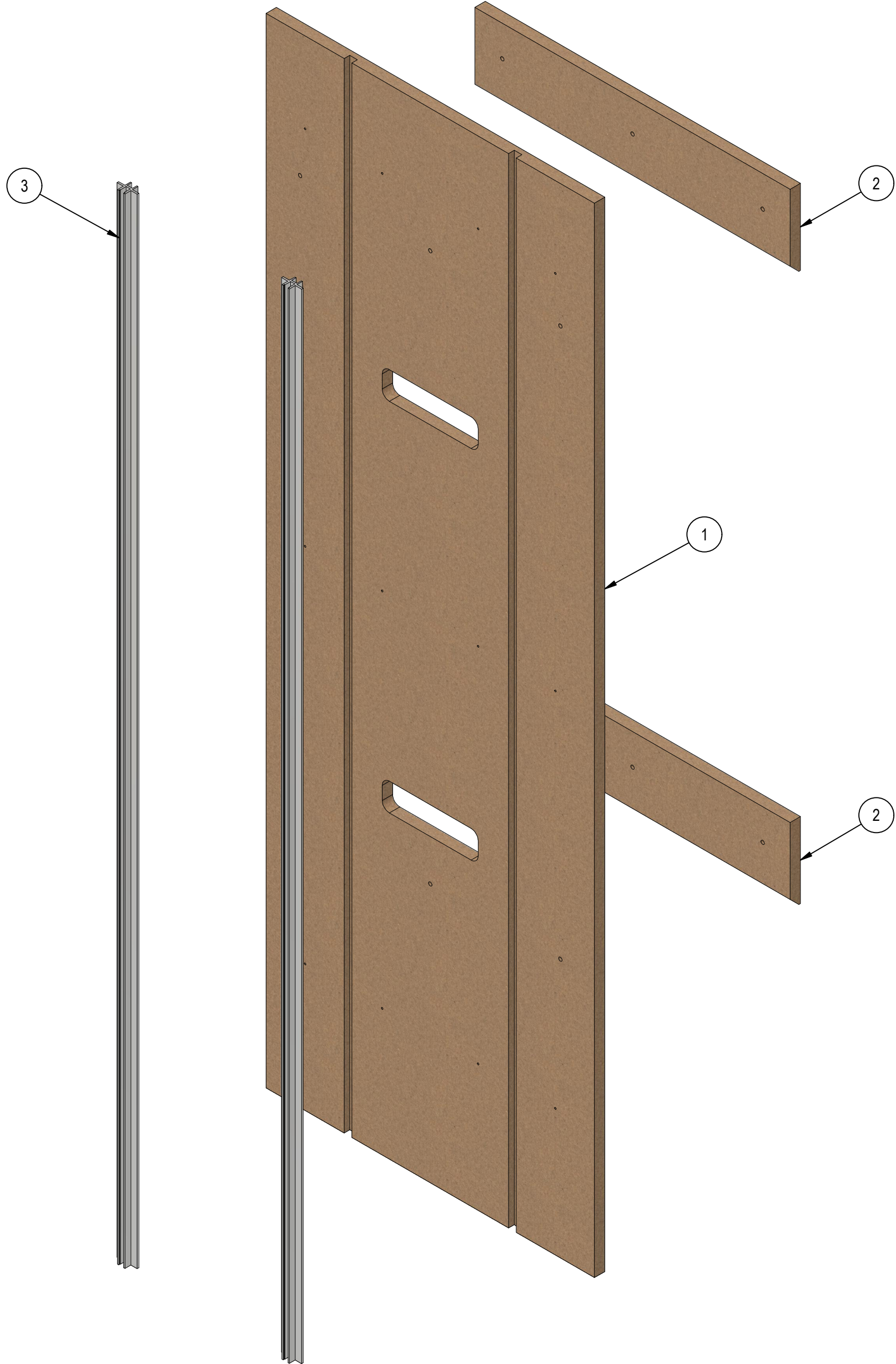

**EXPLODED**  
SCALE 1 / 5.5

**NAPLES BEACH BOUTIQUE**  
**NAPLES, FL**

Description:  
**BACK PANEL ASSEMBLY - 24 INCH**

**Display Craft**  
**MANUFACTURING CO.**

3939 WASHINGTON BOULEVARD BALTIMORE, MARYLAND 21227-4165  
PH: (410) 242-0400 FX: (410) 242-0475  
A DIVISION OF WEITZMAN INDUSTRIES, INC.

- REVISIONS -

BY	DATE	REMARKS

THIS DRAWING REMAINS THE PROPERTY OF DISPLAY CRAFT MFG CO. THE INFORMATION CONTAINED HEREON IS FOR THE SPECIFIC USE OF THE INDIVIDUAL PROJECT, AND MAY NOT BE USED FOR ANY OTHER PURPOSE WITHOUT THE WRITTEN CONSENT OF DISPLAY CRAFT MFG. CO.



PARTS LIST										
ITEM	QTY	PART NUMBER	C.C.	DESCRIPTION	Length	Width	Thk.	Material	Finish	EB
1	1	3083-003B-P01	FC	FINISH PANEL	64.687	5.656	0.51	Medium Density Fiberboard	PRIME ALL FACES	N/A
2	3	STAR_HANGER_227-01	P	227 - 10 lbs HOLD						N/A

DATE:	3/4/2026
DRAWN BY:	BH
FIXTURE NAME:	BB-03
PART #:	3083-BB03B-P
JOB #:	3083
SHEET #:	003.29

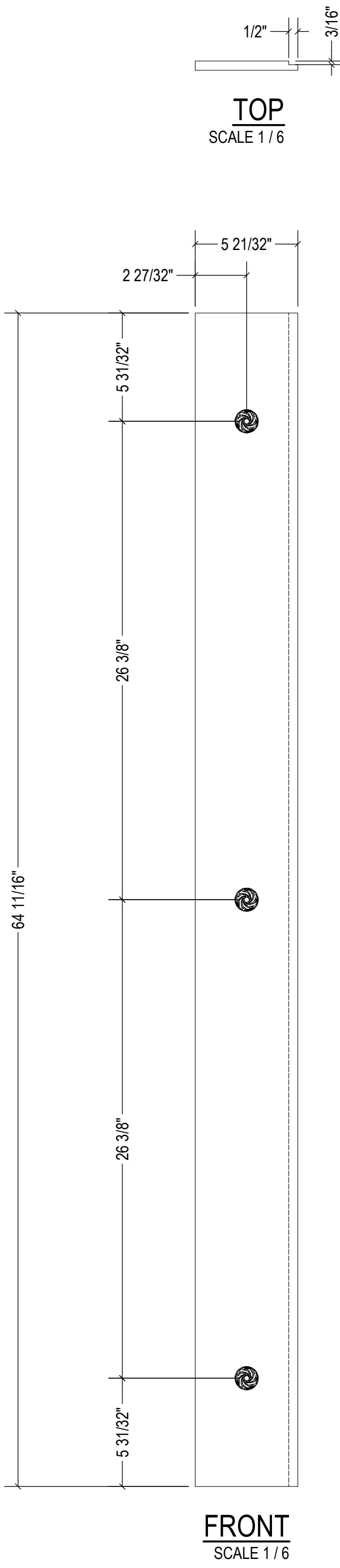

**TOP**  
SCALE 1 / 6

**FRONT**  
SCALE 1 / 6

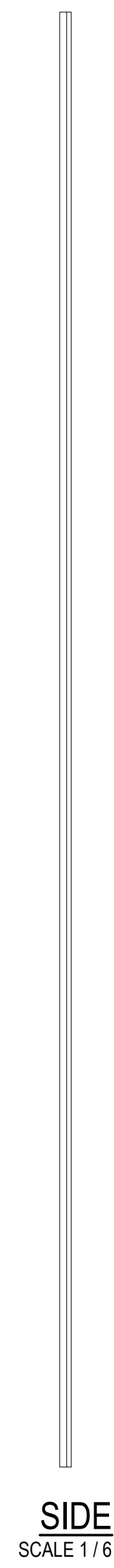

**SIDE**  
SCALE 1 / 6

THIS FACE TO BE COVERED WITH  
PHILLIP JEFFRIES  
PERFORMANCE VINYL  
# 7867 CAPRI NATURAL



**ISO**  
SCALE 1 / 6

**NAPLES BEACH BOUTIQUE  
NAPLES, FL**

Description:  
**FINISH PANEL - 24 INCH OUTSIDE**



3939 WASHINGTON BOULEVARD BALTIMORE, MARYLAND 21227-4165  
PH: (410) 242-0400 FX: (410) 242-0475  
A DIVISION OF WEITZMAN INDUSTRIES, INC.

- REVISIONS -	
BY	DATE

THIS DRAWING REMAINS THE PROPERTY OF DISPLAY CRAFT MFG CO. THE INFORMATION CONTAINED HEREON IS FOR THE SPECIFIC USE OF THE INDIVIDUAL PROJECT, AND MAY NOT BE USED FOR ANY OTHER PURPOSE WITHOUT THE WRITTEN CONSENT OF DISPLAY CRAFT MFG. CO.

PARTS LIST										
ITEM	QTY	PART NUMBER	C.C.	DESCRIPTION	Length	Width	Thk.	Material	Finish	EB
1	1	3083-003B-R01	FC	FINISH PANEL	64.687	22.375	0.51	Medium Density Fiberboard	PRIME ALL FACES	N/A
2	6	STAR_HANGER_227-01	P	227 - 10 lbs HOLD						N/A

DATE:	3/4/2026
DRAWN BY:	BH
FIXTURE NAME:	BB-03
PART #:	3083-BB03B-R
JOB #:	3083
SHEET #:	003.30

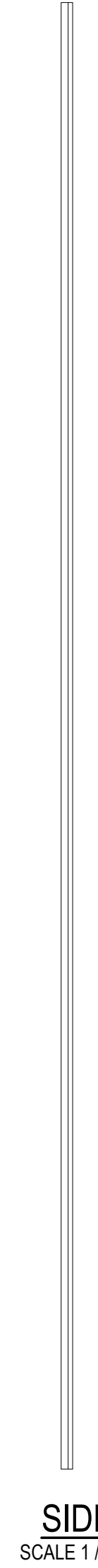
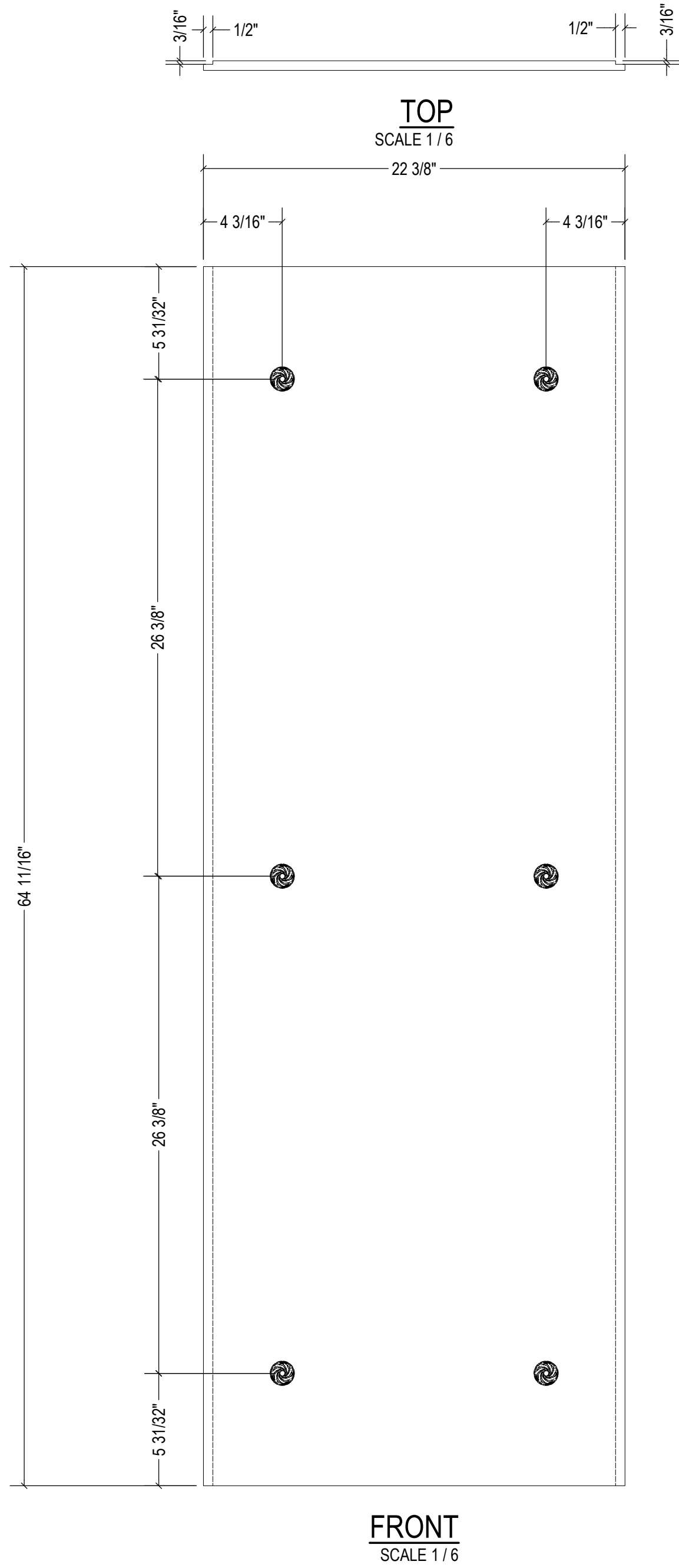

FACE TO BE COVERED WITH  
PHILLIP JEFFRIES  
PERFORMANCE VINYL  
# 7867 CAPRI NATURAL

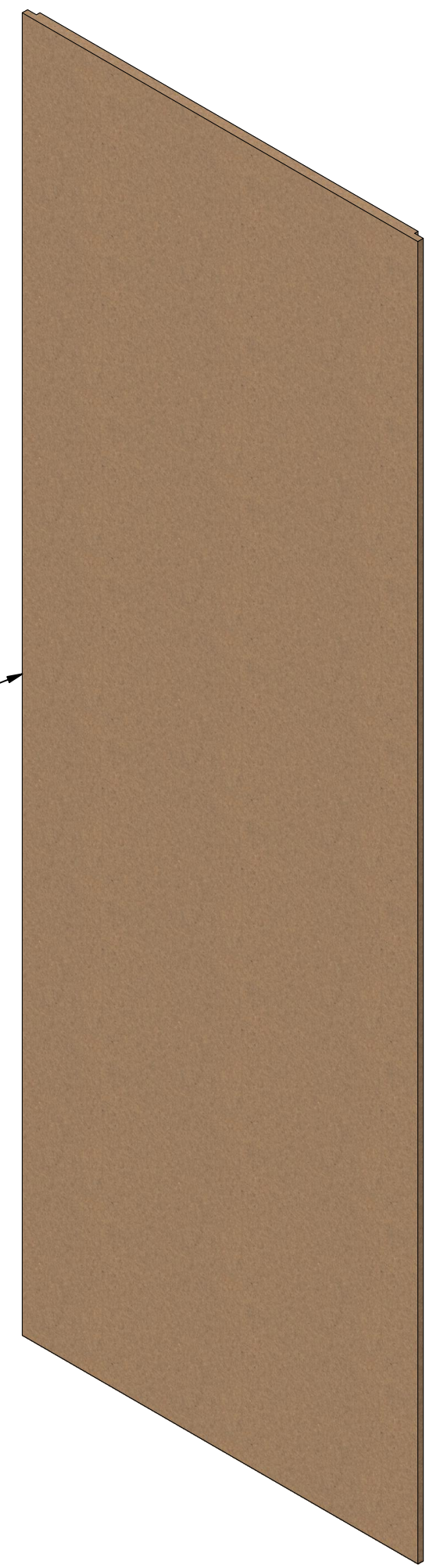

ISO  
SCALE 1 / 6

**NAPLES BEACH BOUTIQUE**  
**NAPLES, FL**

Description:  
**FINISH PANEL - 41 INCH CENTER**



3939 WASHINGTON BOULEVARD BALTIMORE, MARYLAND 21227-4165  
PH: (410) 242-0400 FX: (410) 242-0475  
A DIVISION OF WEITZMAN INDUSTRIES, INC.

- REVISIONS -

BY	DATE	REMARKS

THIS DRAWING REMAINS THE PROPERTY OF DISPLAY CRAFT MFG CO. THE INFORMATION CONTAINED HEREON IS FOR THE SPECIFIC USE OF THE INDIVIDUAL PROJECT, AND MAY NOT BE USED FOR ANY OTHER PURPOSE WITHOUT THE WRITTEN CONSENT OF DISPLAY CRAFT MFG. CO.

PARTS LIST										
ITEM	QTY	PART NUMBER	C.C.	DESCRIPTION	Length	Width	Thk.	Material	Finish	EB
1	1	3083-003B-S01	FC	FINISH PANEL	64.687	11.375	0.51	Medium Density Fiberboard	PRIME ALL FACES	N/A
2	6	STAR_HANGER_227-01	P	227 - 10 lbs HOLD						N/A

DATE:	3/4/2026
DRAWN BY:	BH
FIXTURE NAME:	BB-03
PART #:	3083-BB03B-S
JOB #:	3083
SHEET #:	003.31

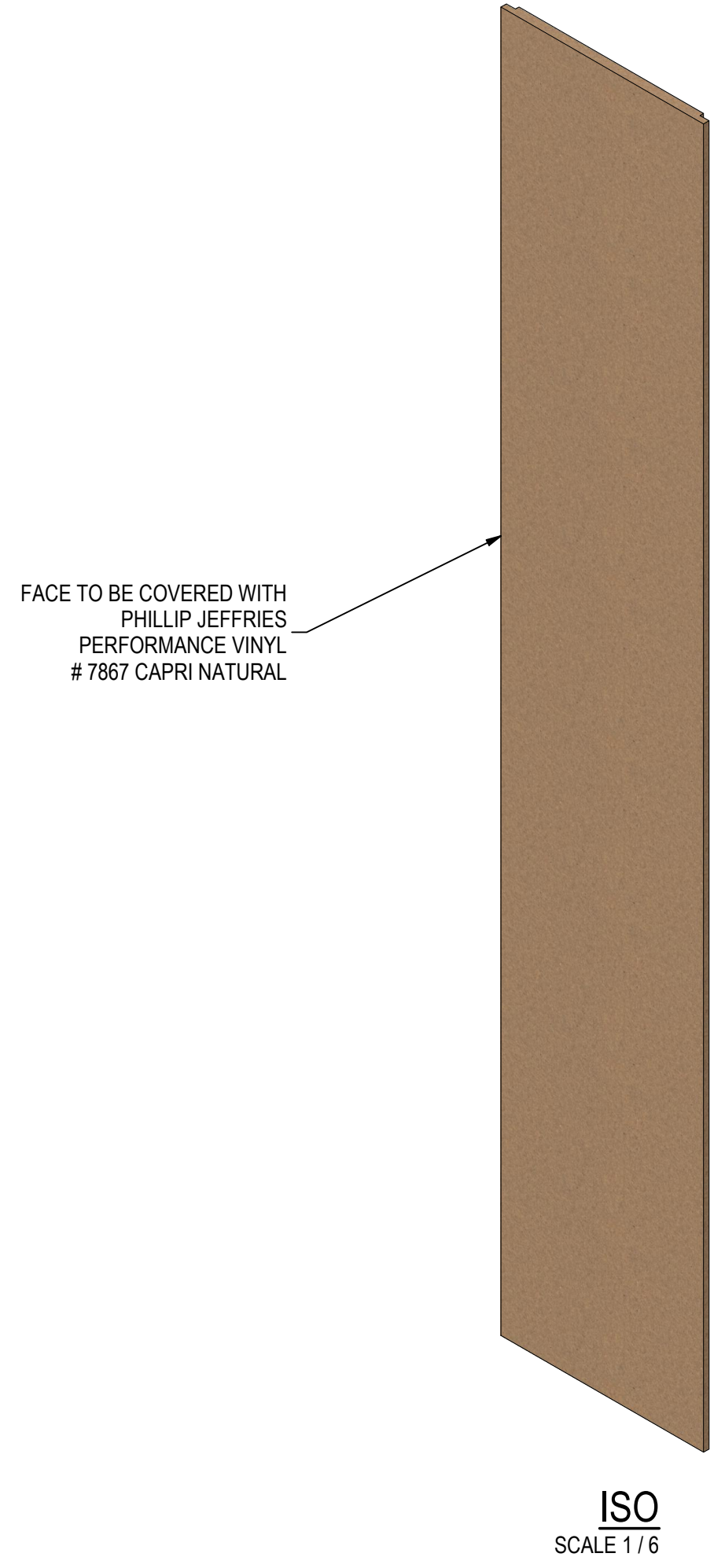
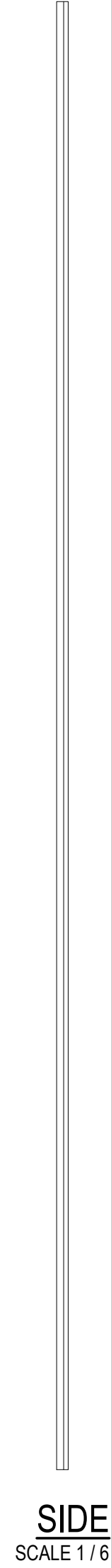
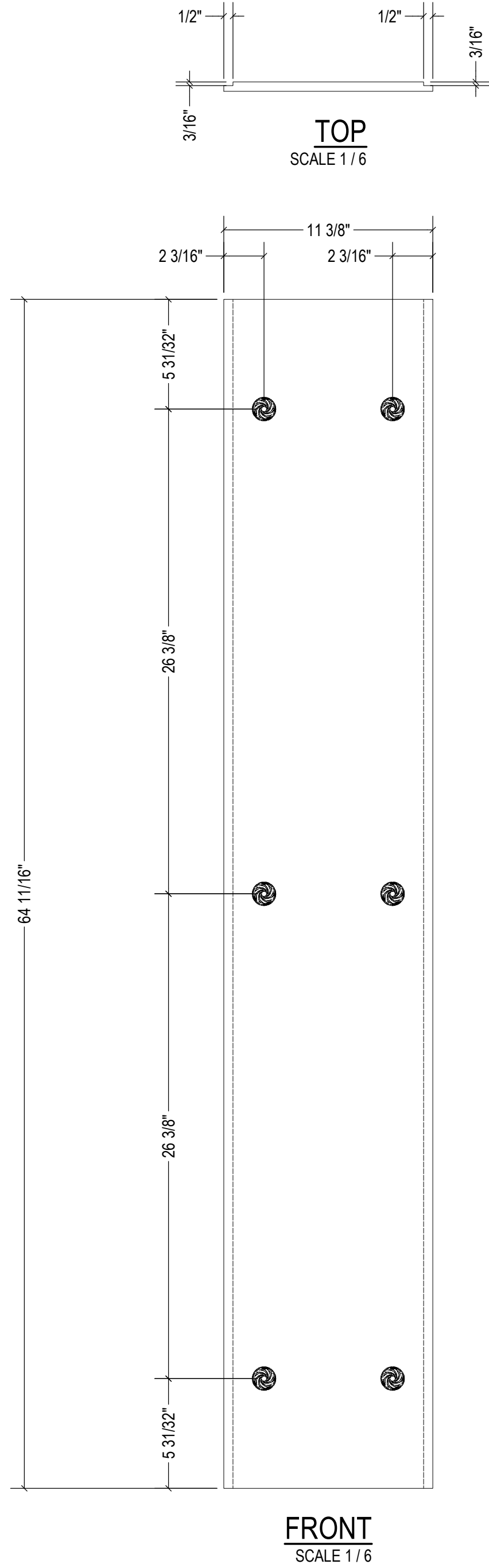

NAPLES BEACH BOUTIQUE  
 NAPLES, FL

Description:  
 FINISH PANEL - 24 INCH CENTER

**Display Craft**  
 MANUFACTURING CO.

3939 WASHINGTON BOULEVARD BALTIMORE, MARYLAND 21227-4165  
 PH: (410) 242-0400 FX: (410) 242-0475  
 A DIVISION OF WEITZMAN INDUSTRIES, INC.

- REVISIONS -

BY	DATE	REMARKS

THIS DRAWING REMAINS THE PROPERTY OF DISPLAY CRAFT MFG. CO. THE INFORMATION CONTAINED HEREON IS FOR THE SPECIFIC USE OF THE INDIVIDUAL PROJECT, AND MAY NOT BE USED FOR ANY OTHER PURPOSE WITHOUT THE WRITTEN CONSENT OF DISPLAY CRAFT MFG. CO.

PARTS LIST										
ITEM	QTY	PART NUMBER	C.C.	DESCRIPTION	Length	Width	Thk.	Material	Finish	EB
1	4	3083-003B-T06	FC	INNER SUPPORTS	17.655	1.25	0.76	Medium Density Fiberboard		N/A
2	1	3083-003B-T01	FC	TOP	23	20.687	0.765	PLYBOO G2S	20% SHEEN CLEAR	N/A
3	1	3083-003B-T02	FC	FONT	23	2	0.765	PLYBOO G2S	20% SHEEN CLEAR	1L
4	1	3083-003B-T03	FC	RISER	21.47	1.25	0.765	PLYBOO G2S	20% SHEEN CLEAR	N/A
5	1	3083-003B-T07	FC	BOTTOM	21.47	18.422	0.25	PLYBOO G2S	20% SHEEN CLEAR	N/A
6	2	3083-003B-T05	FS	SIDE	20.187	1.5	0.765	PLYBOO G2S	20% SHEEN CLEAR	1L
7	2	3083-003B-TV01	FS	SIDE VENEER	20.687	2	0.023	PLYBOO G2S	20% SHEEN CLEAR	N/A
8	2	ADJ SHELF BRACKET	P	BRACKET						
9	4	SELF-MC45-AR01	P	SELF-MC45-AR	1.181	0.45	0.429	Steel Profile		N/A

DATE:	3/4/2026
DRAWN BY:	BH
FIXTURE NAME:	BB-03
PART #:	3083-BB03B-T
JOB #:	3083
SHEET #:	003.32

NAPLES BEACH BOUTIQUE  
NAPLES, FL

ADJUSTABLE SHELF - 24 INCH

Description:



3939 WASHINGTON BOULEVARD BALTIMORE, MARYLAND 21227-4165  
PH: (410) 242-0400 FX: (410) 242-0475  
A DIVISION OF WEITZMAN INDUSTRIES, INC.

- REVISIONS -

BY	DATE	REMARKS

THIS DRAWING REMAINS THE PROPERTY OF DISPLAY CRAFT MFG CO. THE INFORMATION CONTAINED HEREON IS FOR THE SPECIFIC USE OF THE INDIVIDUAL PROJECT, AND MAY NOT BE USED FOR ANY OTHER PURPOSE WITHOUT THE WRITTEN CONSENT OF DISPLAY CRAFT MFG. CO.

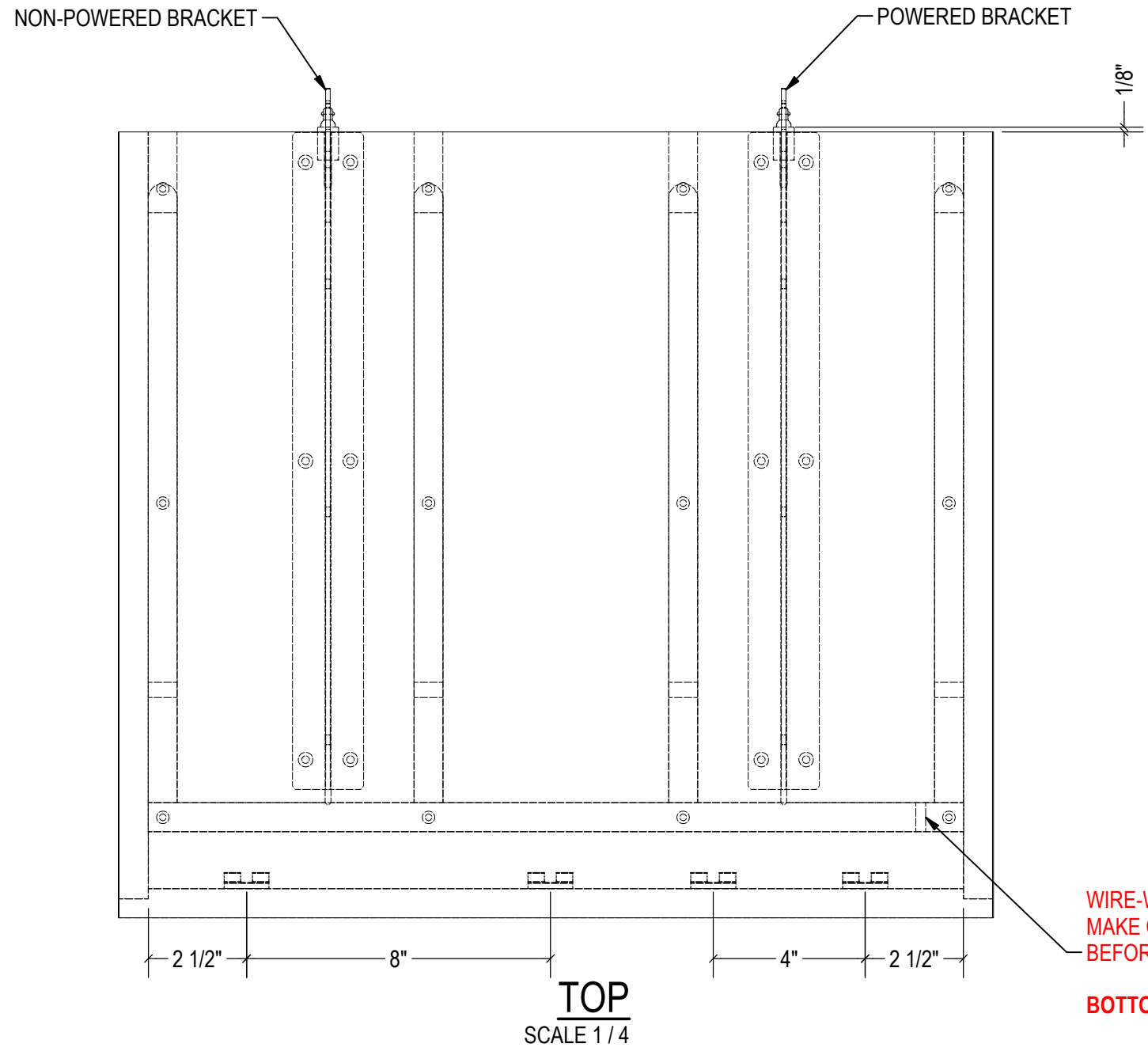

WIRE-WAY THIS SIDE  
MAKE CONNECTION TO BRACKET  
BEFORE ATTACHING BOTTOM  
BOTTOM IS SCREWED AND FAST-CAPPED ONLY

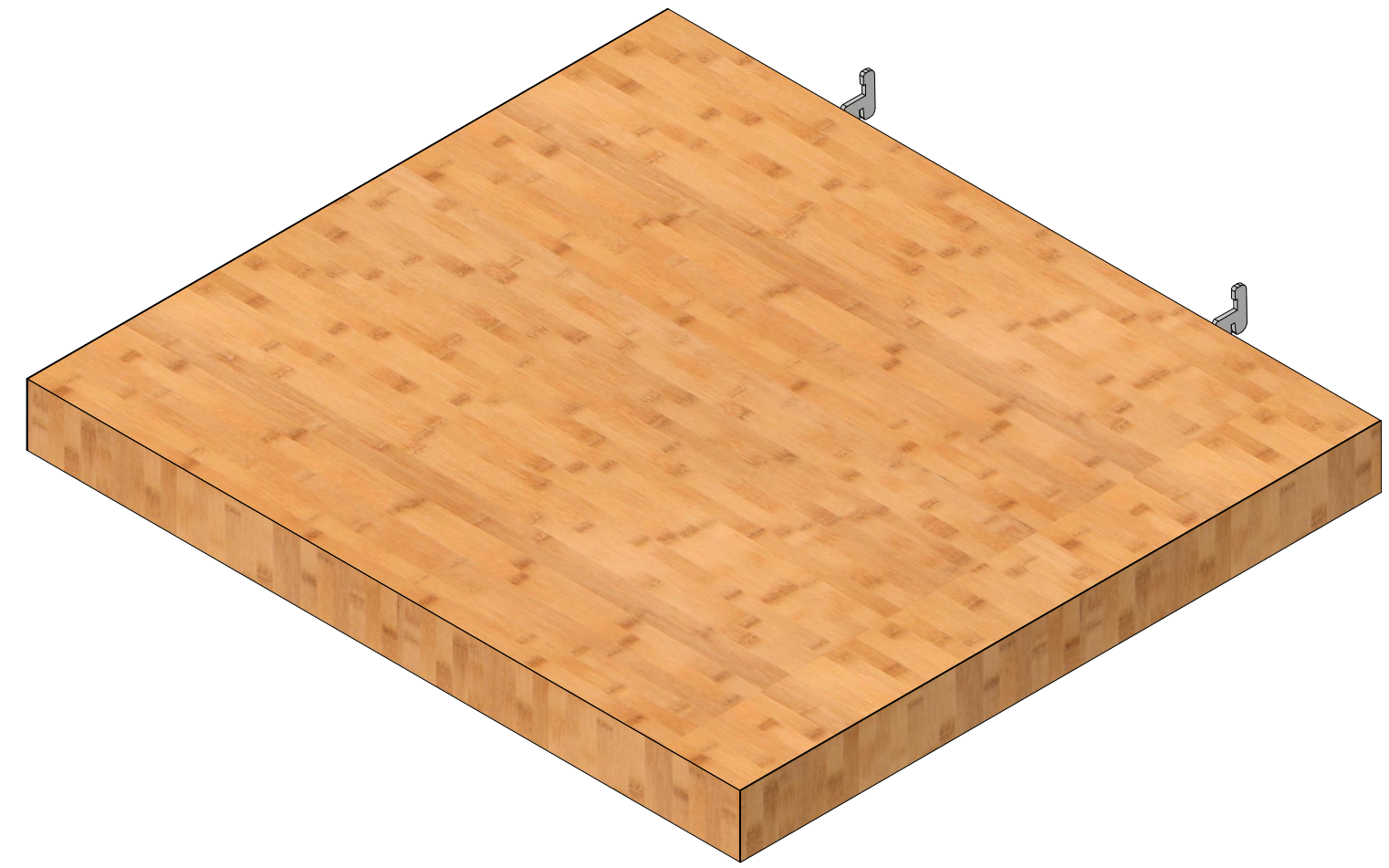

ISO  
SCALE 1/4

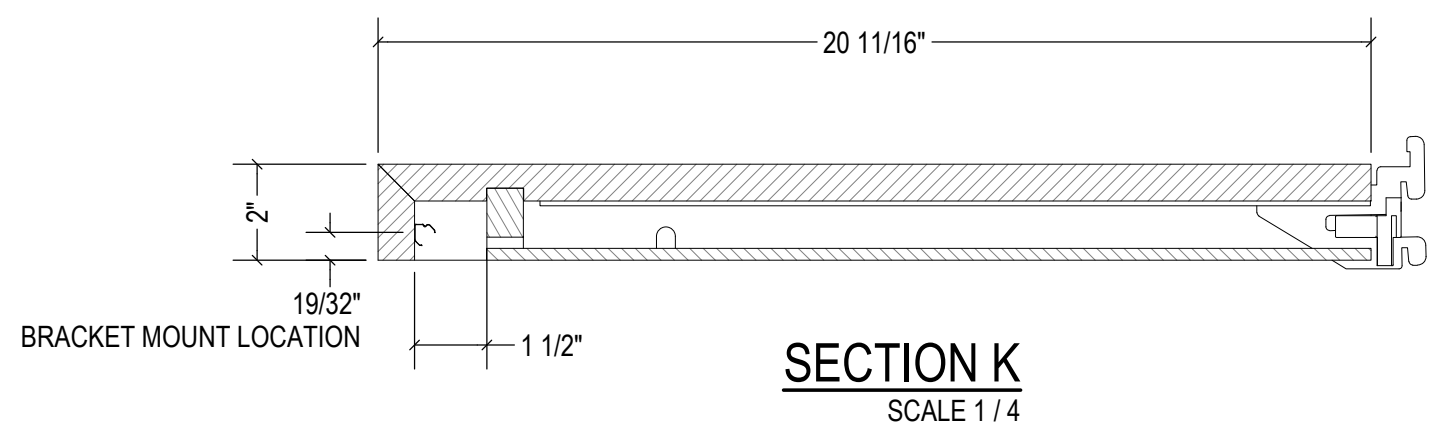
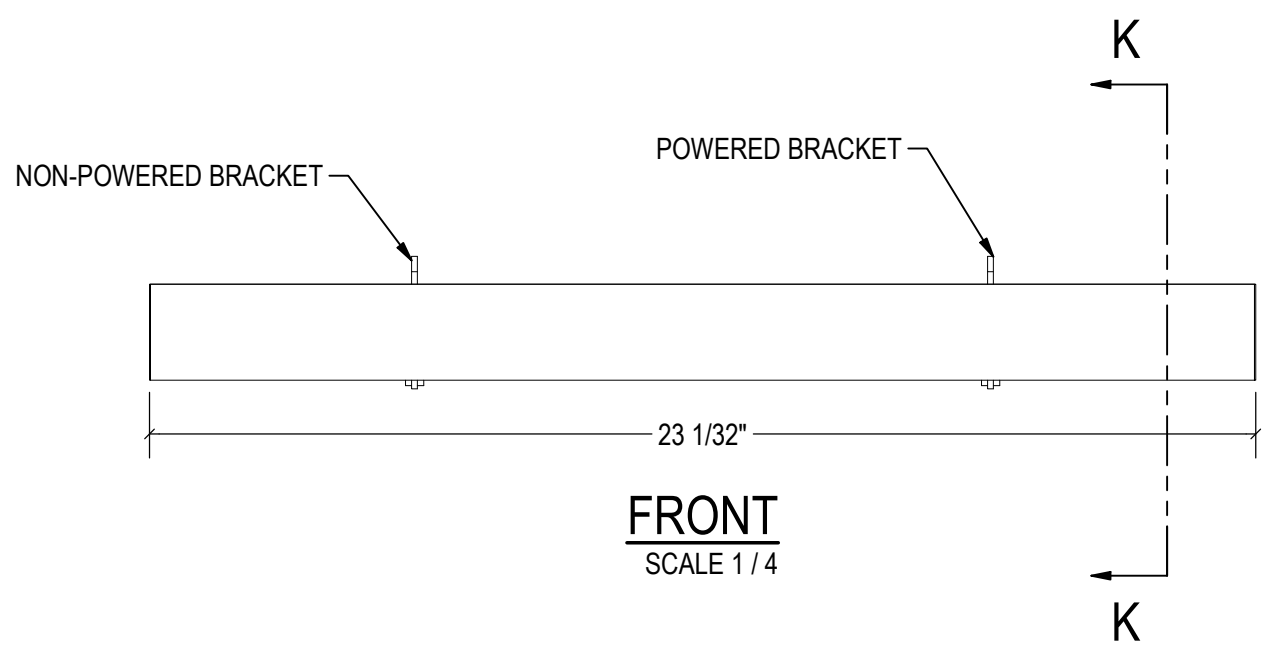

SECTION K  
SCALE 1/4

PARTS LIST										
ITEM	QTY	PART NUMBER	C.C.	DESCRIPTION	Length	Width	Thk.	Material	Finish	EB
1	4	3083-003B-T06	FC	INNER SUPPORTS	17.655	1.25	0.76	Medium Density Fiberboard		N/A
2	1	3083-003B-T01	FC	TOP	23	20.687	0.765	PLYBOO G2S	20% SHEEN CLEAR	N/A
3	1	3083-003B-T02	FC	FONT	23	2	0.765	PLYBOO G2S	20% SHEEN CLEAR	1L
4	1	3083-003B-T03	FC	RISER	21.47	1.25	0.765	PLYBOO G2S	20% SHEEN CLEAR	N/A
5	1	3083-003B-T07	FC	BOTTOM	21.47	18.422	0.25	PLYBOO G2S	20% SHEEN CLEAR	N/A
6	2	3083-003B-T05	FS	SIDE	20.187	1.5	0.765	PLYBOO G2S	20% SHEEN CLEAR	1L
7	2	3083-003B-TV01	FS	SIDE VENEER	20.687	2	0.023	PLYBOO G2S	20% SHEEN CLEAR	N/A
8	2	ADJ SHELF BRACKET	P	BRACKET						
9	4	SELF-MC45-AR01	P	SELF-MC45-AR	1.181	0.45	0.429	Steel Profile		N/A

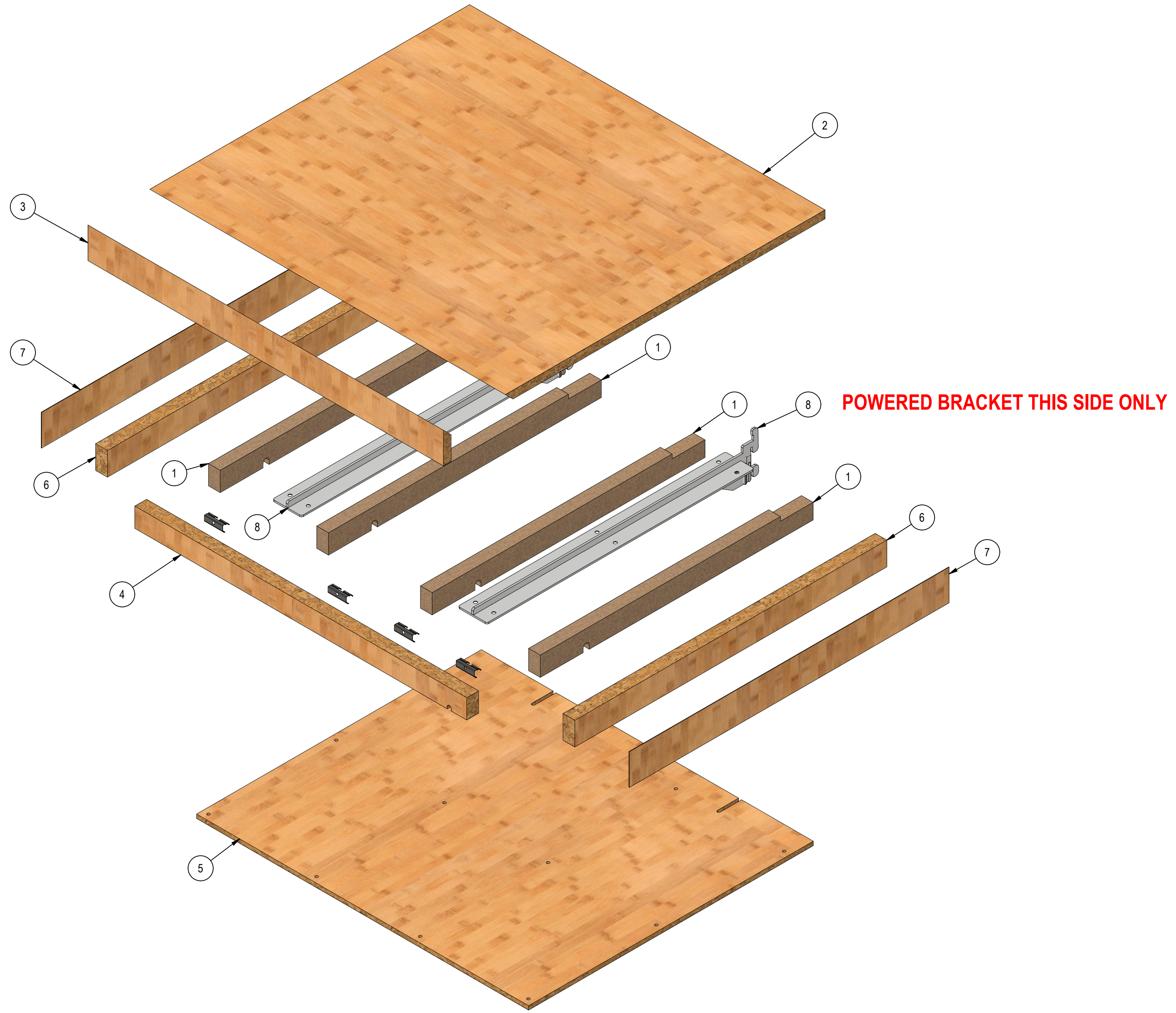

**EXPLODED**  
SCALE 1/3.5

**NAPLES BEACH BOUTIQUE**  
**NAPLES, FL**

**ADJUSTABLE SHELF - 24 INCH**

**DisplayCraft**  
**MANUFACTURING CO.**

3959 WASHINGTON BOULEVARD BALTIMORE, MARYLAND 21227-4165  
PH: (410) 242-0400 FX: (410) 242-0475  
A DIVISION OF WEITZMAN INDUSTRIES, INC.

- REVISIONS -

BY	DATE	REMARKS

THIS DRAWING REMAINS THE PROPERTY OF DISPLAY CRAFT MFG. CO. THE INFORMATION CONTAINED HEREON IS FOR THE SPECIFIC USE OF THE INDIVIDUAL PROJECT, AND MAY NOT BE USED FOR ANY OTHER PURPOSE WITHOUT THE WRITTEN CONSENT OF DISPLAY CRAFT MFG. CO.

DATE: 3/4/2026  
DRAWN BY: BH  
FIXTURE NAME: BB-03  
PART #: 3083-BB03B-T  
JOB #: 3083  
SHEET #: 003.33